



Uniblock

Quattro macchine in una
Four machines in one



AMS Ferrari Srl
Via Bazzini, 131 · 41122 Modena (Mo) · Tel. +39 059/317238 · Fax +39 059/454276
www.amsferrari.it · info@amsferrari.it



Uniblock

Quattro macchine in un'unica macchina per una linea completa automatica di risciacquo, riempimento, chiusura ed etichettatura.

Uniblock

Four machines in a single unit for a complete automatic rinsing, filling, closing and labelling line.

Caratteristiche tecniche Monoblocco AstraMatic

AstraMatic monoblock technical specifications

Model	RT 9.1	RT 12.1	RT 16.1
B/H	1500	2000	3000
D MIN-MAX	50-108	50-108	50-108
H MIN-MAX	160-330	160-330	160-330
POWER	KW 2.2	KW 2.2	KW 3
AIR CONS.	200NL/1"	200NL/1"	200NL/1"
WEIGHT KG	1100	1400	1700
DIM. "A"	1780	1780	1780
DIM. "B"	2080	2080	2080
DIM. "C"	1050-1150	1050-1150	1050-1150
DIM. "H"	2380	2380	2380

Flessibile

Massima Flessibilità nella configurazione delle lavorazioni per tipologia di prodotti e di formati.

Flexible

Maximum Flexibility in terms of operating configuration by type of products and sizes.

Pratica

In uno spazio ridotto di 3,5 metri di lunghezza e 2 metri di larghezza è possibile installare un impianto completo per l'imbottigliamento.

Practical

In a small space, 3.5 metres long and 2 metres wide, a complete bottling system can be installed.

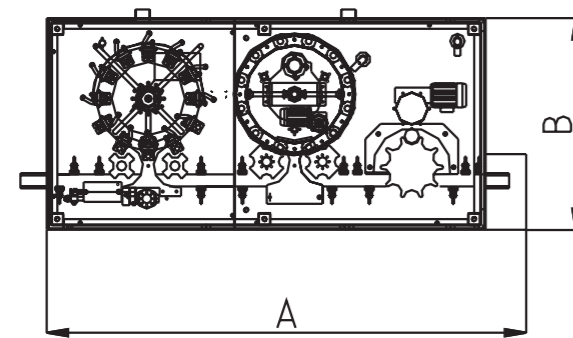
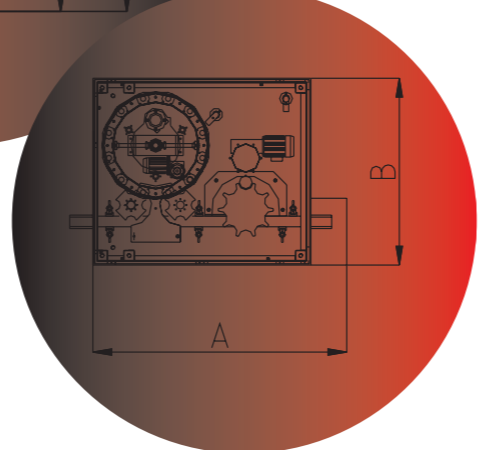
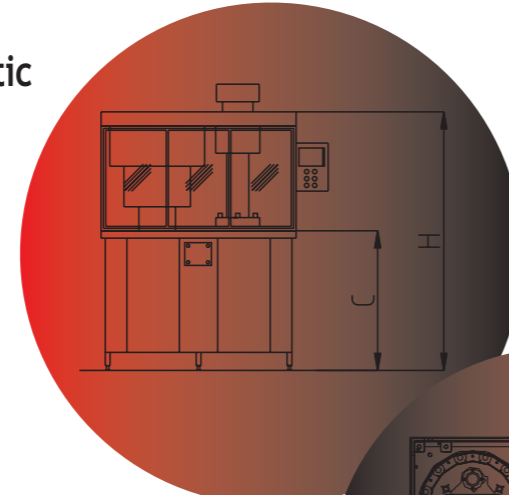

Caratteristiche tecniche Triblocco AstraMatic

AstraMatic triple-block technical specifications

Model	SRT 9.9.1	SRT 12.12.1	SRT 16.1
B/H	1500	2000	3000
D MIN-MAX	50-108	50-108	50-108
H MIN-MAX	160-330	160-330	160-330
POWER	KW 2.2	KW 3	KW 3
AIR CONS.	200NL/1"	200NL/1"	200NL/1"
WAT. CONS.	220LT/H	240LT/H	350LT/H
WEIGHT KG	1800	2150	2450
DIM. "A"	1780	1780	1780
DIM. "B"	3040	3040	3310
DIM. "C"	1050-1150	1050-1150	1050-1150
DIM. "H"	2380	2380	2380

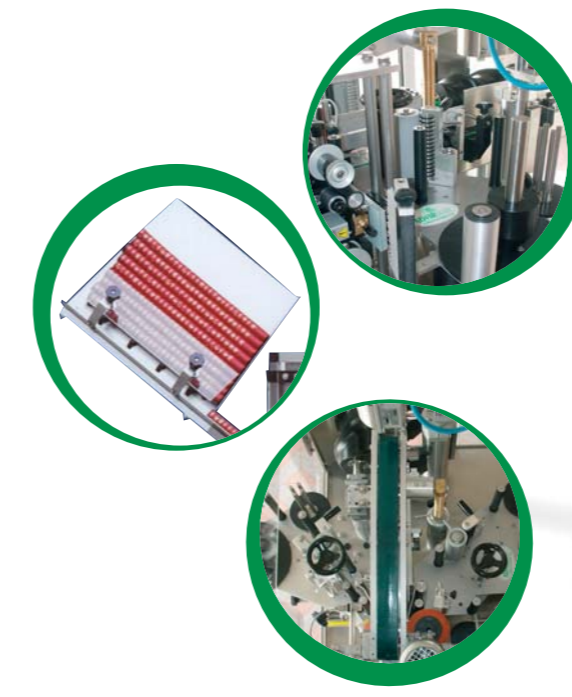
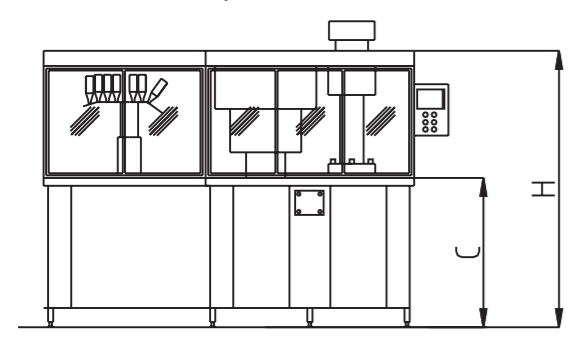

Caratteristiche tecniche Monoblocco + Etichettatrice

Monoblock + Labeller technical specifications

Model	RTE 9.1.1	RTE 12.1.1	RTE 16.1.1
B/H	1500	2000	3000
D MIN-MAX	50-108	50-108	50-108
H MIN-MAX	160-330	160-330	160-330
POWER	KW 3.7	KW 3.7	KW 4.5
AIR CONS.	200NL/1"	200NL/1"	200NL/1"
WEIGHT KG	1500	1900	2100
DIM. "A"	1953	1953	1953
DIM. "B"	2500	2500	2500
DIM. "C"	1800	1800	1800
DIM. "D"	1050-1150	1050-1150	1050-1150
DIM. "H"	2400	2400	2400

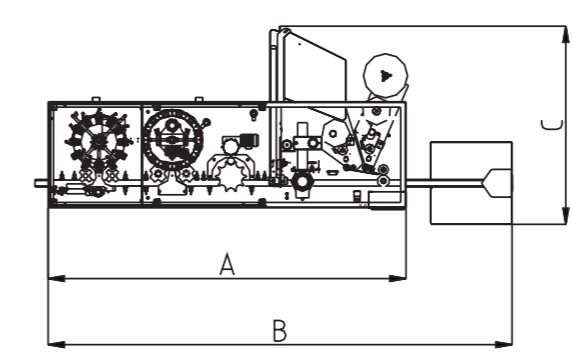
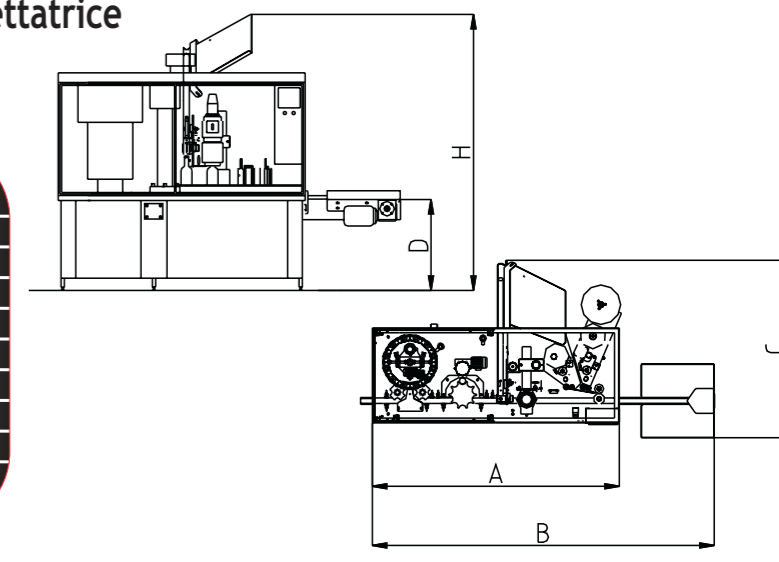

Caratteristiche tecniche Triblocco + Etichettatrice

Triple-block + Labeller technical specifications

Model	SRTE 9.1.1	SRTE 12.1.1	SRTE 16.1.1
B/H	1500	2000	3000
D MIN-MAX	50-108	50-108	50-108
H MIN-MAX	160-330	160-330	160-330
POWER	KW 3.7	KW 4.5	KW 4.5
AIR CONS.	200NL/1"	200NL/1"	200NL/1"
WAT. CONS.	220LT/H	220LT/H	220LT/H
WEIGHT KG	2300	2550	3000
DIM. "A"	2953	2953	2953
DIM. "B"	3500	3500	3500
DIM. "C"	1800	1800	1800
DIM. "D"	1050-1150	1050-1150	1050-1150
DIM. "H"	2400	2400	2400

