

Hydraulic Units UP100 S309 Version

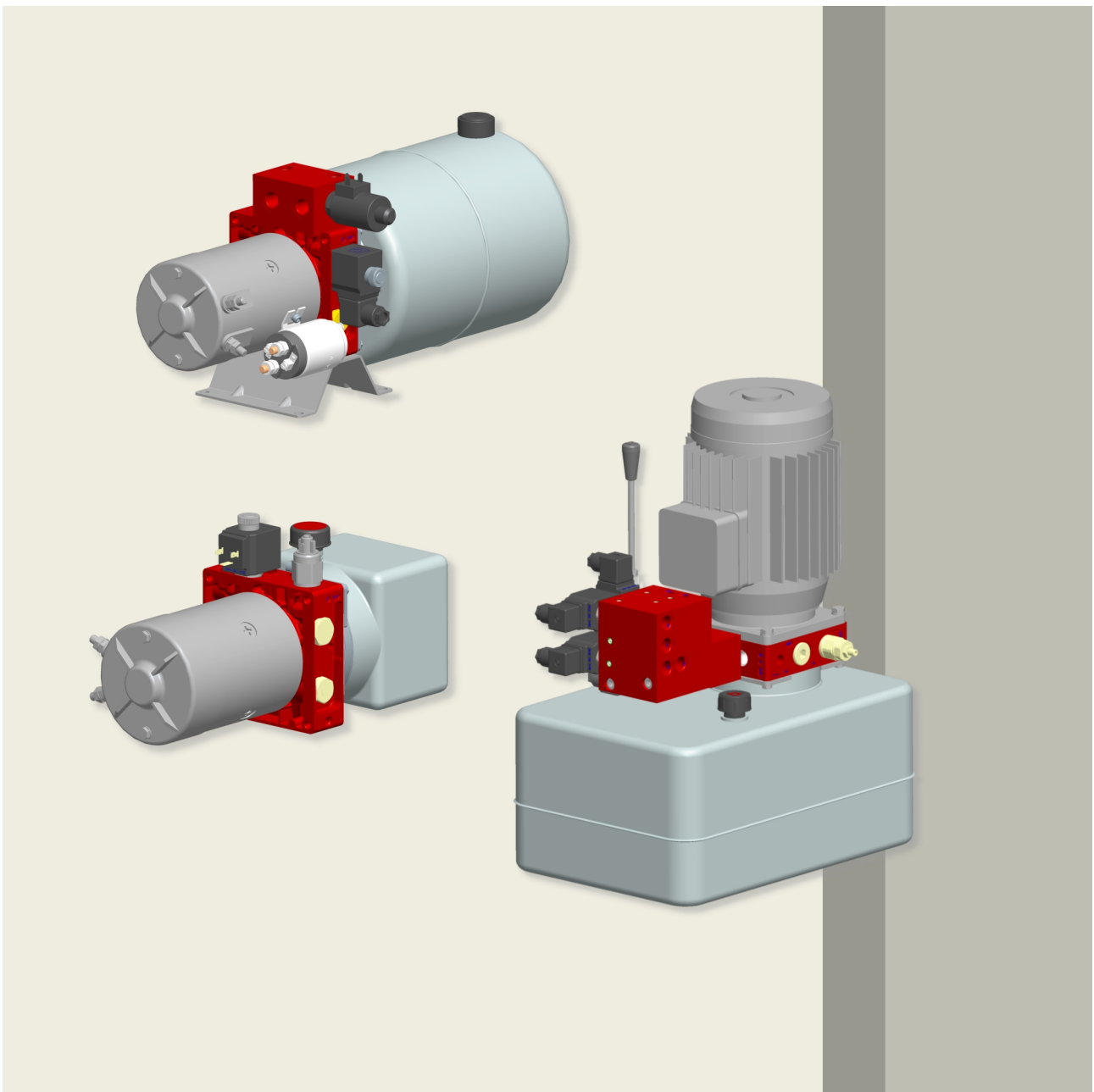

motion and progress

Contents

Changes in the Power Units UP100 S309 version	5
General information	6
Integrated housings	8
External manifolds	9
Sub-assemblies making up UP100 power pack	11
1 Power pack housing	12
1.1 Technical information	12
1.2 Housing UP100K1 (Single acting)	14
1.3 Housing UP100K3 (Manifolds prearrangement or threaded P-T connections)	19
1.4 Housing UP100K4 (integrated valves + external manifolds)	25
1.5 Housing UP100K6 (Single acting)	31
1.6 Preassembled housing	35
2 Gear pumps	36
2.1 Technical information	36
2.2 Single unidirectional pumps - Counterclockwise rotation	38
2.3 Double pumps with Hi-Lo valve - Counterclockwise rotation	39
3 Tanks	40
3.1 Plastic tanks	40
3.2 Metal tanks up to 18 litres	52
4 Suction/return assembly kits	60
4.1 Suction assembly kits for plastic tanks	64
4.2 Suction assembly kits for metal tanks	66
4.3 Accessories	67
5 Electric motors	67
5.1 D.C. motors	67
5.2 A.C. motors	84
6 Drives	90
6.1 Introduction	90
6.2 Drives for D.C. motors	91
6.3 Drives for A.C. motors	91
6.4 Drives E145	92
6.5 Drives E156	92
6.6 Drives E163	92
6.7 Drives E131	93
6.8 Drives E132	93
6.9 Drives E133	94
6.10 Drives E137	94
6.11 Drives E181	95
7 Cartridge valves	96
7.1 Introduction	96
7.2 Pressure Relief Valves	99
7.3 Check valves	100
7.4 Solenoid operated directional valves	101
7.5 Proportional solenoid valve: PDF817/HSC	109
7.6 Manual override valves	111
7.7 Directional valves	111
7.8 Flow control valves	113
7.9 Manual lowering valve	116
7.10 Emergency hand pumps	122
7.11 Valve cavity plugs	124

8	Manifolds	126
8.1	Technical information	126
8.2	Intermediate plate 2144 for manifold 5073-5033-5053-2083-2043-2013	126
8.3	Parallel circuit - Provision for solenoid valves CETOP	126
8.4	Series circuit - Suitable for solenoid valves DIN24350 FORM A CETOP R35H - ISO4401	128
8.5	Series circuit - Circuit with more than three solenoid valves DIN24350 FORM A CETOP R35H -ISO4401	128
8.6	Spacer plate 4210 for manifolds: 5073- 5033-5053-2083-2043-2013 DIN24350 FORM A CETO PR35H-ISO4401	128
8.7	Solenoid valves DIN 24350 FORM A CETOP R35H - ISO4401	130
8.8	Manifolds with direct thread ports P and T for K3P001 and K4P001 housings	131
8.9	Intermediate manifold for UP100K3P001 Suitable for PM817/1.5 manual pump	131
8.10	Special blocks interface 5203	132
8.11	Manifold for HDS11-HDS07 directional control valve - Vertical mounting	133
8.12	Manifold for HDS11 - HDS07 directional control valve - Horizontal mounting	133
8.13	Special block 3151	134
8.14	Special block 3051	135
8.15	Special block 3152	136
8.16	Special block 5200	137
8.17	Special block 5201	138
8.18	Special block 3542	139
8.19	Special block 3547	140
8.20	Special block 3552	141
8.21	Special block 3593	142
8.22	Special block 4560	143
9	Directional control valves	144
9.1	Introduction	144
9.2	Directional control valve HD105	144
9.3	Directional control valve HD106	146
10	Complete power packs	148
10.1	Typical application for Dock Levellers	148
10.2	Typical application for Snow Plow	149
10.3	Typical application for Invalid Lift Equipment	150
10.4	Typical application for Tailgate	151
10.5	Typical application for Lift Table	152
10.6	Modular system	153
11	Components	154
11.1	Pressure gauge	154
11.2	Steel plate bracket pressed for UP housing	154
11.3	Protective cover for D.C. motors	154
11.4	Microswitch	154
11.5	Pressure switch	155
12	Operation and maintenance	156
12.1	Oil	156
12.2	Starting	156
12.3	Maintenance	156
12.4	Dealing with possible trouble	156
13	Composition of hydraulic power pack ordering code	158

Changes in the Power Units UP100 S309

In order to pursue a continuous improvement and standardisation policy of its products, Bucher Hydraulics introduces some changes in the power unit UP100, concerning the following components: body, filter conveyor, gear pump and suction group as follows:

- Power unit body

The S309 power unit body UP100 includes a cavity "b" as seat of the check valve, that is placed 1 mm upward compared to the S409 UP100 body (picture 1).

In order to facilitate the identification of the S309 UP100 power bodies, we mark on three sides such specific classification codes. In this way, it is possible to identify which pump type rigs the power unit, without disassembling the tank (pictures 2)

(Picture 1)

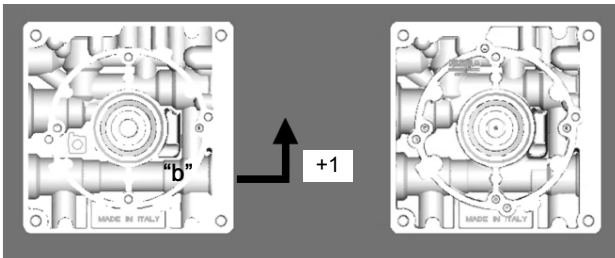

(Pictures 2)

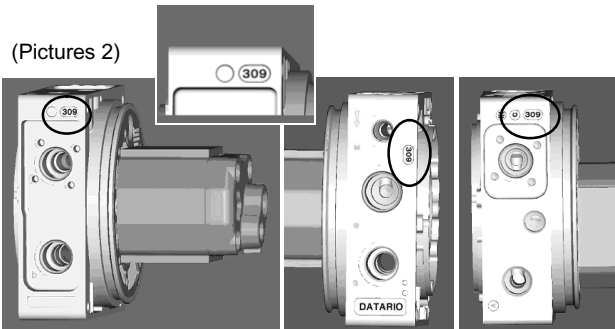

- Filter Conveyor

The picture on the left shows the previous filter conveyor. The new type, on the right, is the same assembled on power Units UP110.

UP100 S409

UP100 S309

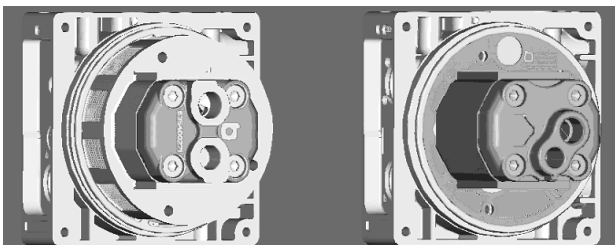

- Single Gear Pump

Detailed picture of the two S409-S309 different pumps type.

The picture on the left shows the version AP100 series S409, and on the right the pump series S309, that is externally recognizable by the new back cover.

The two pumps are internally different as they have different balancing plates.

This characteristic doesn't allow the interchangeability between series S409 and S309; in the S309 body UP100 it is possible to assemble the new pump series S309, only.

UP100 S409

UP100 S309

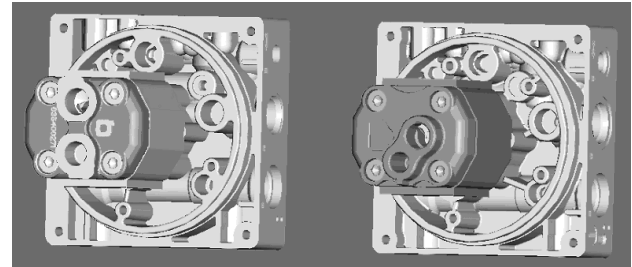

- Suction group

The new back cover of the pump series S309, has the suction placed exactly in the middle of the power unit body.

This enable to use the same suction group, by reducing consequently the model quantities for each different horizontal assembling positions.

UP100 S409

UP100 S309

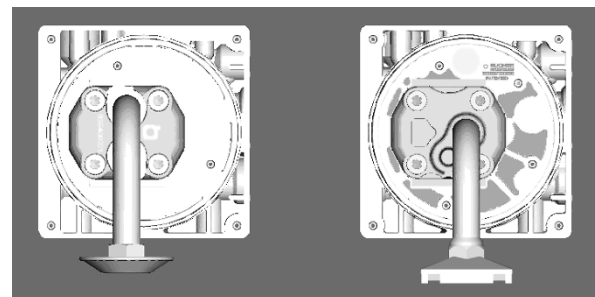

The width of pump series S309, as it is shown on the right of picture below, is 5 mm longer than the series S409.

This increase is a constant for any pump displacement, because generated by height increase of the back cover.

UP100 S409

UP100 S309

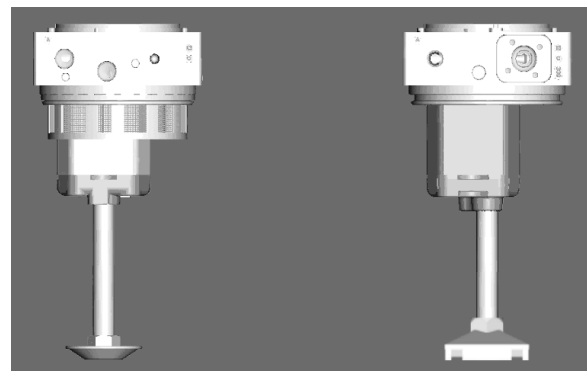

General information

Experience acquired in designing mini power packs, and a research effort aimed constantly at satisfying the technical specifications of our customers: these assets have provided the principal resource for development of the UP100 power packs:

- maximum flexibility, allowing the assembly of a great number of different circuits from just 4 basic versions;
- economy of the manufactured product, gained by adopting innovative technologies and by standardizing valve cavities with those of the major hydraulic components manufacturers;
- the assurance of constant quality, thanks to comprehensive control on materials and production cycles;
- compact dimensions achieved through detailed analysis of the geometries involved, and of the components used.

Illustrated are some of the various typical applications for UP100 hydraulic power packs.

Power packs are widely utilized in the field of industrial materials handling machines. Lift trucks is a good example, where the compactness of the unit is a particular advantage in view of the limited space available.

The need for fluid power in mobile machines means that power packs can be exploited in the widest variety of applications: lift platforms, and equipment for handling high and bulky loads in general.

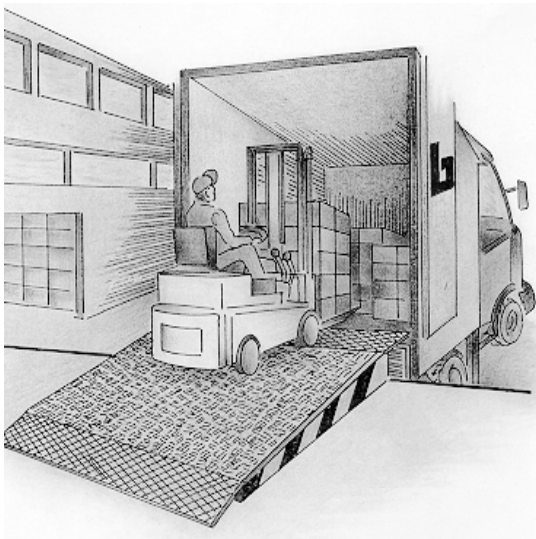
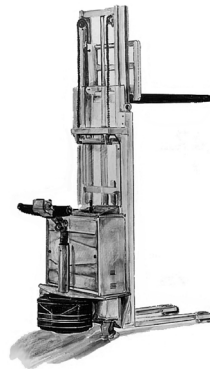
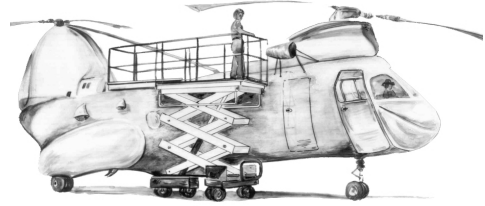

Given the facility of integrating power packs with valve blocks designed and constructed to selected functional and dimensional specifications, special circuits can be customized for automation of the most complex machines.

There are also countless applications for industrial machines and stationary equipment in general where the attributes of the power pack are instrumental in simplifying the hydraulic system, bringing significant saving on installation and running cost.

**WARNING!**

Bucher Hydraulics is not responsible for misuse or misapplication of product. Pressure valves, type and number of cycle have to be considered before choosing the type of product. For any question about applications, please contact Bucher Hydraulics.

All the installation and maintenance operations of partially completed machinery must be made by technically competent personnel.

The hydraulic power units due to its construction does not perform the function of the safety component. So the user must insert safety components into the machine to protect against the possibility of breakage during operation.

The hydraulic power units can not function independently and are designed to be integrated into hydraulic systems.

Fluids should be contained and disposed of properly.

Prior to performing any maintenance make sure the equipment is turned off and that any stored energy, for example pressure, is released. Also, extended equipment or cylinders should be lowered and mechanically locked as required.

During the handling of the hydraulics power units, do not lift the unit by the tank or valves mounted on it (see the figure 1, the arrows indicate the points to lift). Always wear appropriate safety gloves and footwear.

Always wear eye protection and protective clothing when working on and around hydraulic systems.

Remove jewellery and objects that might conduct electricity while working on power units.

Hydraulic fluid does pose a fire hazard, can cause burning or skin irritation if not properly handled.

Fluid under pressure can pierce the skin and enter the bloodstream causing death or serious injury.

Devices being operated by the hydraulic system should be immobilized so they cannot move and cause injury while being inspected or repaired. Disconnect from electrical source.

The above warnings are to be adhered to in order to reduce the risks resulting from the normal usage of the hydraulic power units for the safety and health of the users. The product you have purchased is guaranteed for a period according to existing regulations.

The warrant you will be void if the product has been installed or used in a manner not in accordance with our instructions, or if it was tampered with, modified, subjected to usage outside those prescribed.

Fig.1

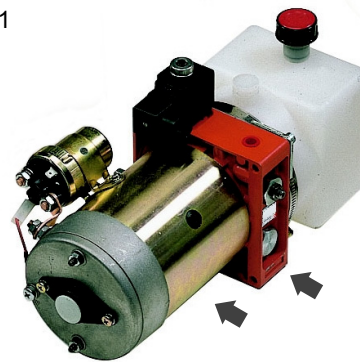
**Directives and standards**

Atex:



Attention- The equipment and protective systems of these catalogue ARE NOT intended for use in potentially explosive atmospheres that is to say where there is an explosive atmosphere referred to in Article 2 of the Directive 99/92/EC and referred to Article 1.3 of the Directive 94/9/EC

D ISO 9001: 2000

Bucher Hydraulics S.p.A. is certified for research, development and production of directional control valves, power units, gear pumps and motors, electro pumps, cartridge valves and integrated operating blocks for hydraulic applications.

Integrated housings

Based on customer demand, many different choices are available:

- wide range of std die-cast housings, designed for high flexibility and compact solutions

- new series of housings obtained from extruded bar for customised applications

Die cast version

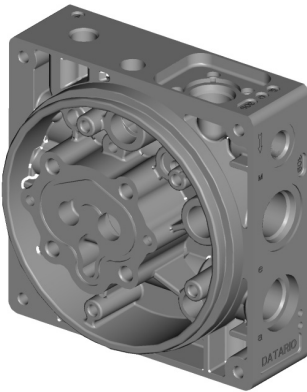
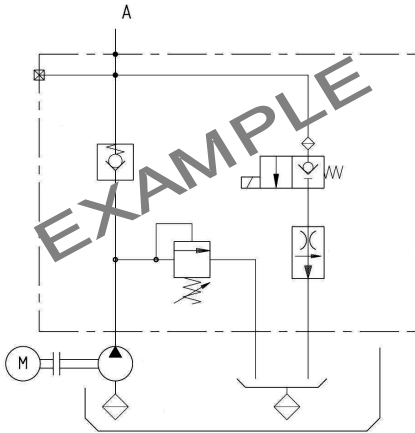

- Cheaper cost
- Standardised solutions

Extruded bar version

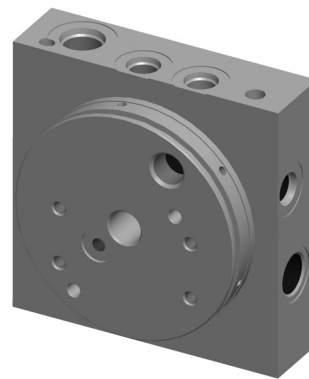
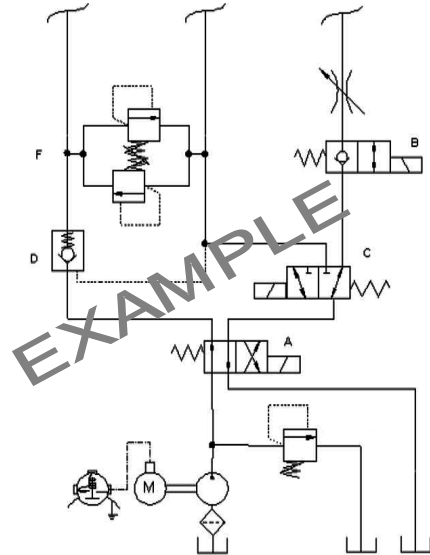

- Fully customised solutions
- Dedicated circuits and valves on Customer demand
- Flexible lay out for ports and valves position

External manifolds

New solutions available also for external manifolds.
A new intermediate plate 5203 has been designed to al-

low the assembling of manifolds made with alternative
interface on standard UP100K4-P0* housing.

Manifolds directly assembled on UP100 housing

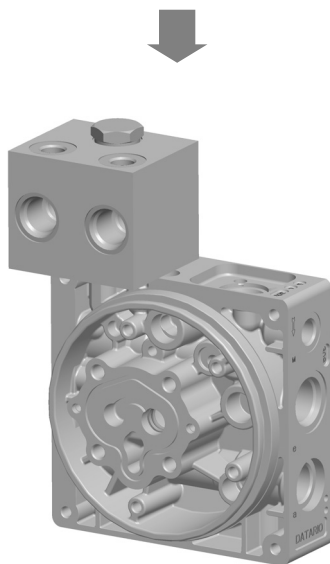
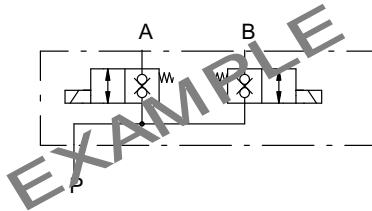

- Cheaper customised solutions
- More complicate hydraulic circuits with standardised manifolds.

Manifolds assembled with 5203 intermediate plate

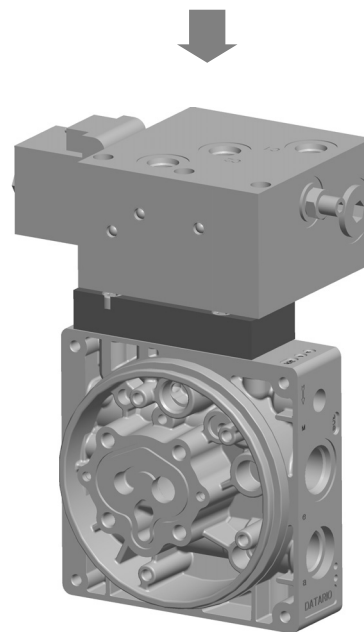
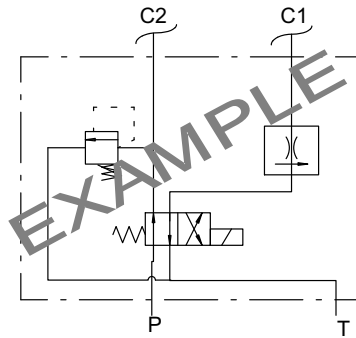

- Wide range of existent or customised blocks with alternative interface.

Sub-assembly index

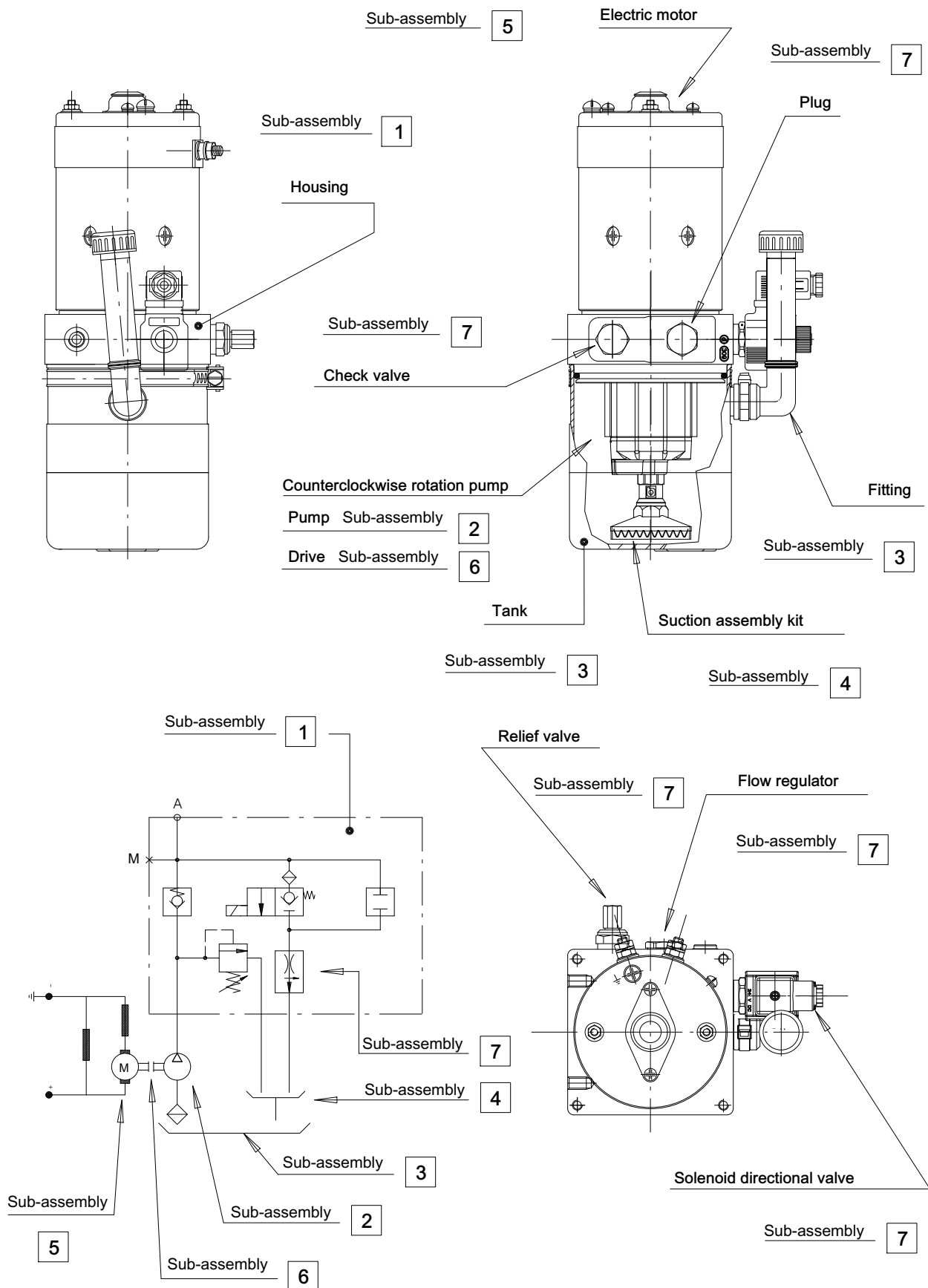

Sub-assemblies making up UP100 power pack

This page serves both as a guide to the contents of the catalogue and as an order form.

Simply fill in the individual sections with the designation codes for the options selected, and send direct to the Bucher Hydraulics S.p.A. Sales Department.

1	Type of housing	Vers.																												
2	Pump	Hi-Lo	Series																											
3	Tank	Fitting	Pos.																											
4	Suction assembly kit	Tank fixing kit	Fill in this section only when ordering single sub-assemblies. Leave blank when ordering complete power packs.																											
5	Electric motor	Pos.	Relay	Pos.																										
6	Drive																													
7	Cavity a										Cavity b										Cavity c									
	Cavity d										Cavity e										Cavity f									
	Cavity g										Hand lever					Lever stick					Volt									
8	Sequence	Manifolds	Valves for manifolds										Qty.	Volt																
9	El. n.	Sectional valve housing	Circuit	Posit.	Lever	Hand Lever	Valves for sec. valve																							

1 Power pack housing

1.1 Technical information

1.1.1 Materials

Housing: pressure diecast aluminium alloy GdAlSi12CuFe to EN-AB 47100 (UNI 5079).

Seals:

- O-Ring seal on the pump outlet: Buna N
- O-Ring seal on tank: Buna N
- Our own design back-up ring pump : Buna N

Our own design back-up ring pump: ZYTEL E10 3HS
Shaft seal ring: NBR

1.1.2 Versions

The design has been developed in such a way that one basic pattern can be exploited to obtain four different casting versions, designated: K1 - K3 - K4 - K6.

1.1.3 Maximum operating pressures

230 bar is the maximum continuous operating pressure resulting from test, though higher values are possible subject to approval by Bucher Hydraulics Engineers.

1.1.4 Pumps

The four housing versions are intended for use with:

Single pump AP100 S.309 CCW rotation.

Double pump AP100+AP100 CCW rotation with integrated pressure cut-off valve for HI-LO versions.

1.1.5 Valves cavities

Standard cavities will allow 3/4-16 UNF and 7/8-14 UNF cartridge valves manufactured by Bucher Hydraulics S.p.A., which are interchangeable with similar components made by major European and US manufacturers.

The only exception is the pressure relief valve threaded M20x1.5, according to Bucher Hydraulics standard.

A variety of hydraulic circuits can be obtained with the same housing. To facilitate the correct composition of the desired hydraulic circuit, the position of each cavity is identified by a letter. The combination letter/cavity position remains unchanged for all the various UP100K.... housings.

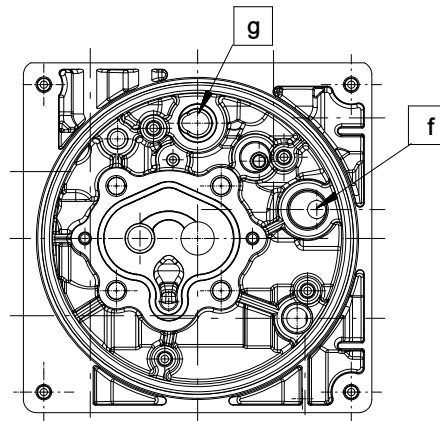
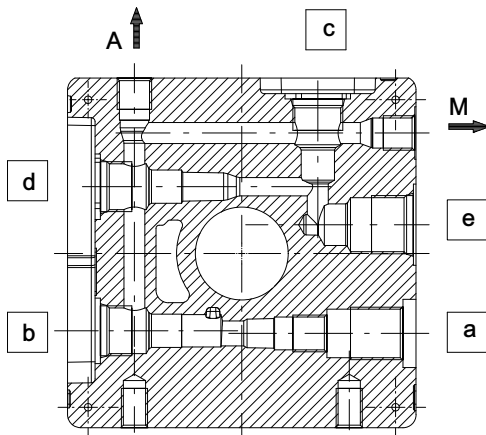

1.1.6 Non-standard symbols used in the text

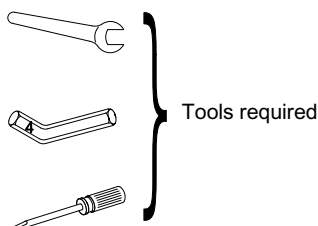

1.1.7 Recommended tightening torques

Port	Nm
- 1/4" BSP	30 ⁰ _{+0.5}
- 3/8" BSP	40 ⁰ _{+0.5}
- M18X1.5	40 ⁰ _{+0.5}
- SAE6	20 ⁰ _{+0.5}



The appropriate power pack housing for the required hydraulic circuit can be identified from the following block diagram.

To facilitate selection, typical hydraulic circuits example are indicated for each housing.

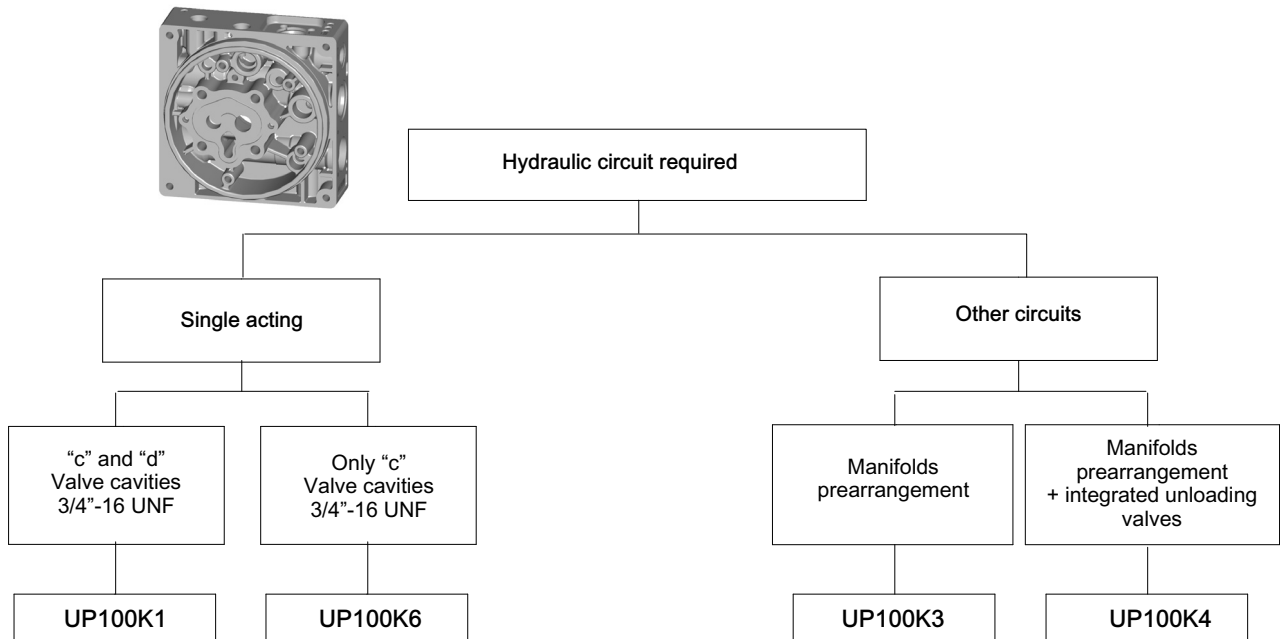

Typical hydraulic circuits

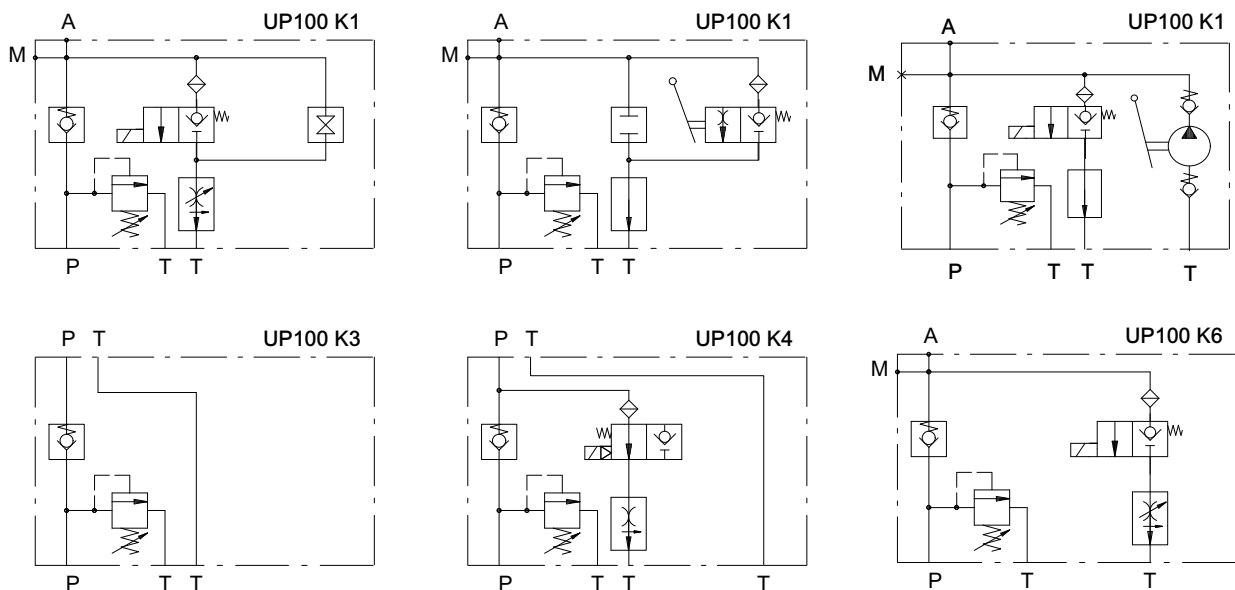

1.2 Housing UP100K1 (Single acting)

1.2.1 Main specification

Cavity **a** = M20X1.5 (relief valve cavity)

Cavity **b** = 3/4"-16 UNF (check valve cavity)

Cavity **c** = 3/4"-16 UNF (directional valve cavity)

Cavity **d** = 3/4"-16 UNF (directional valve cavity)

Cavity **e** = 7/8"-14 UNF (flow regulator cavity)

Cavity **f** = return line

- **A** = Main work port

- **M** = Secondary work port

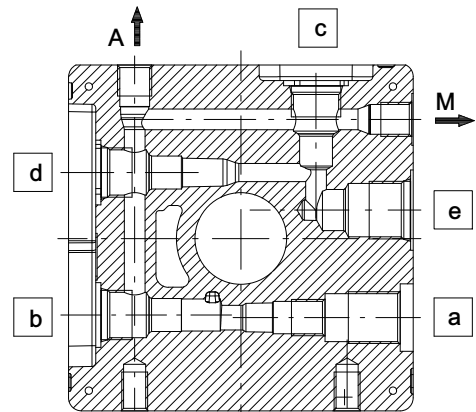

Cavities identification

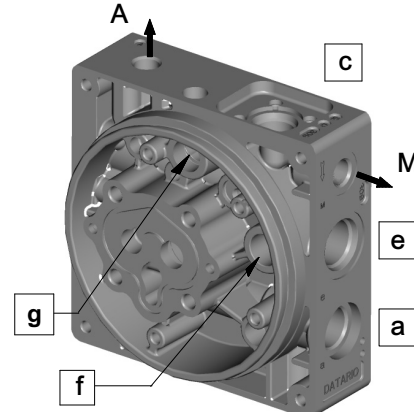
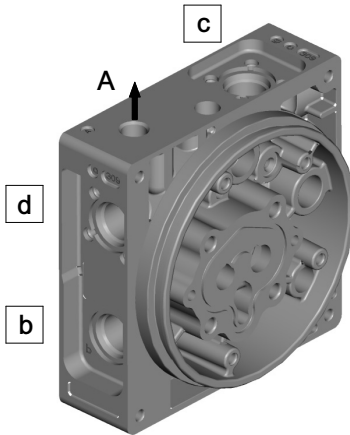

Basic circuit

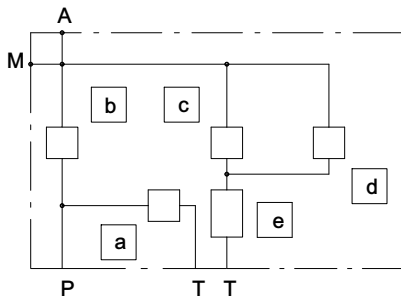

Example for a standard circuit

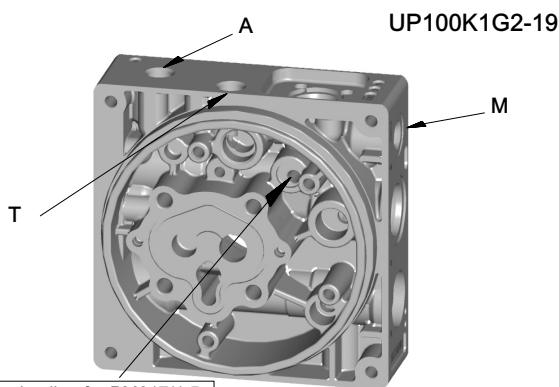
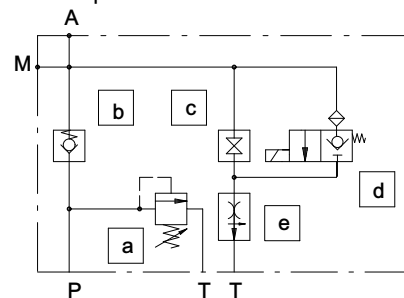

Example for a realizable circuit UP100K1G2-19 (PM817/1.5)

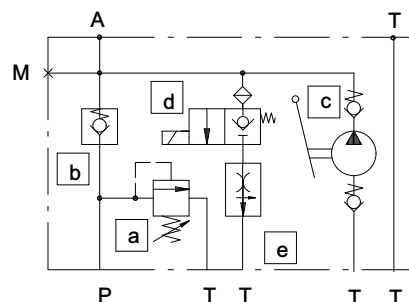

1.2.2 Flexibility of assembly

The two hydraulic circuits illustrated are identical in terms of operation but differently arranged, simply by installing the valves in alternative positions.

Available space can be exploited to the best advantage.

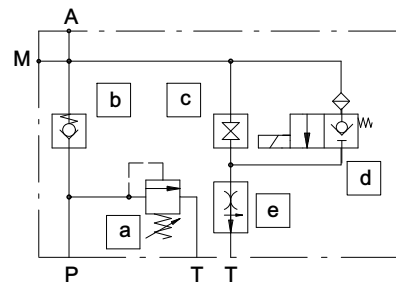
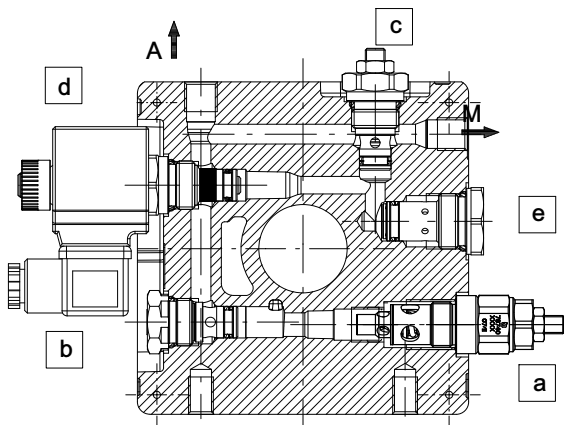
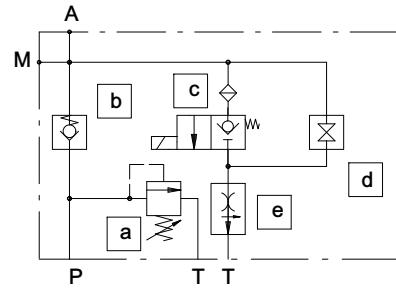
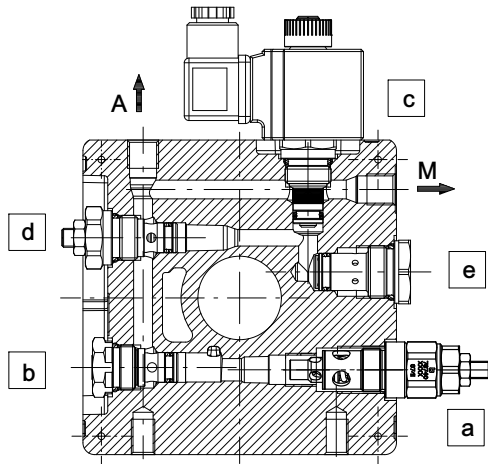

UP100K1G2-19 dedicated version for PM817/1.5 hand pump

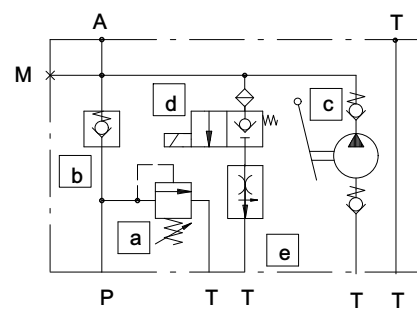
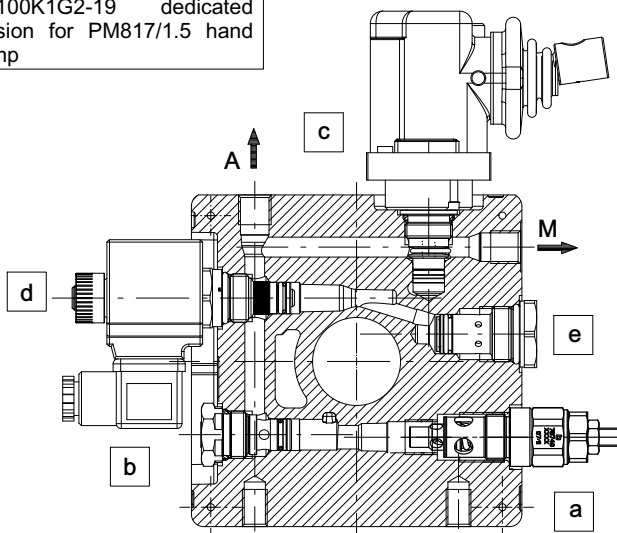

1.2.3 Component accepted by the single cavities

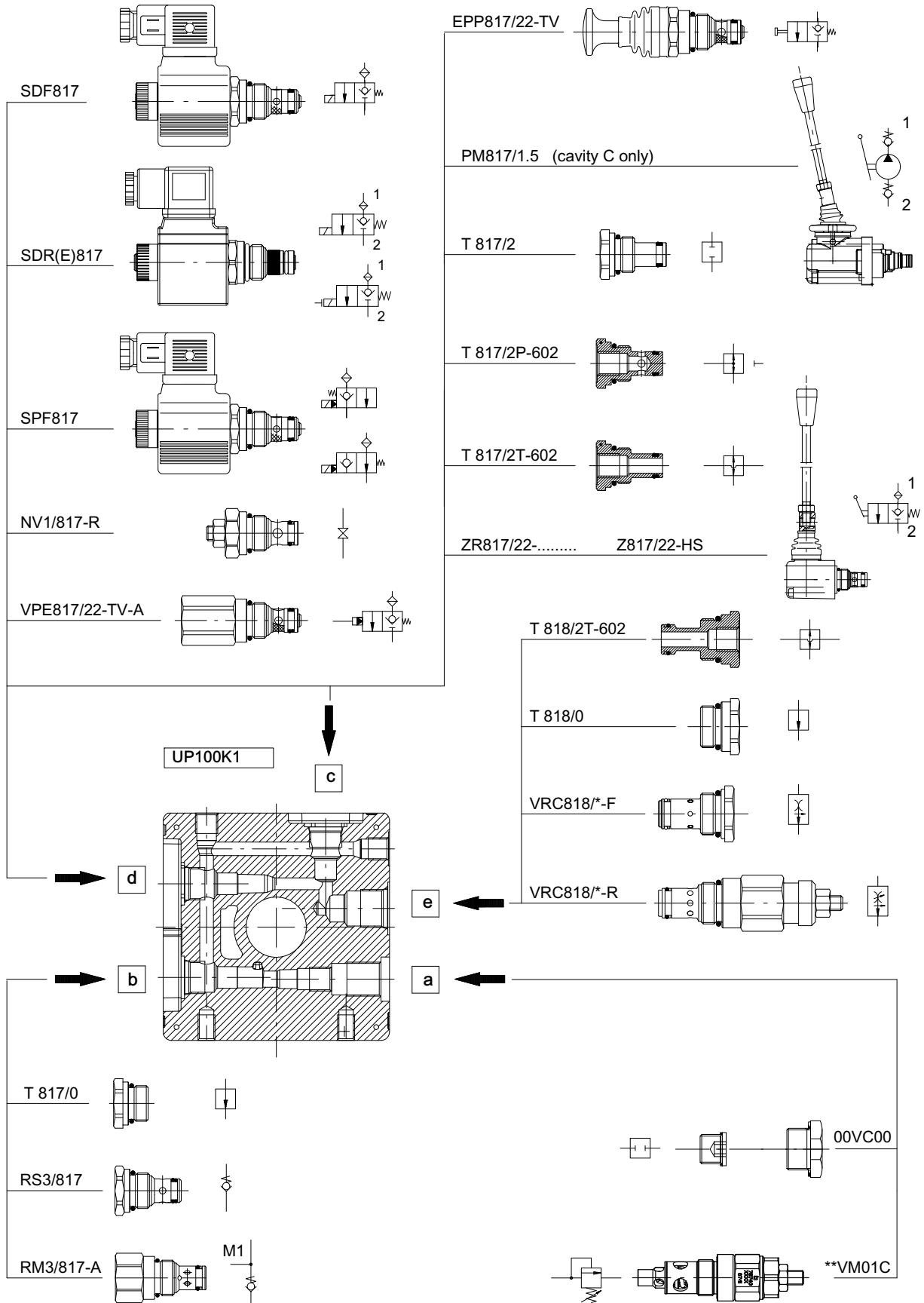

1.2.4 Dimensions

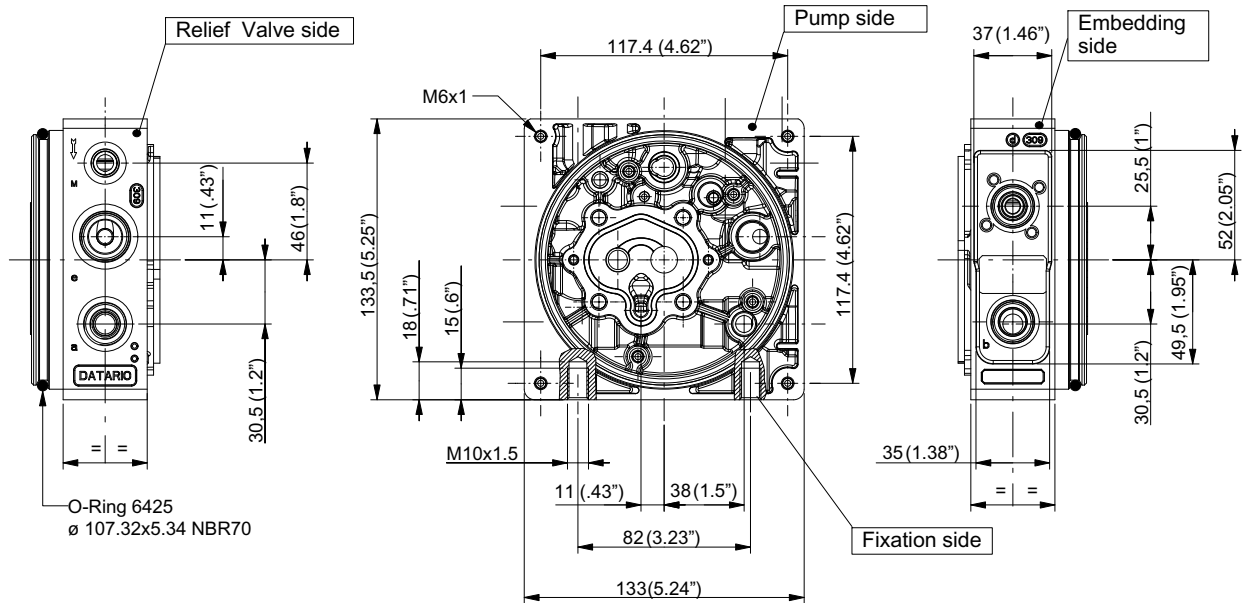

Sec. A-A

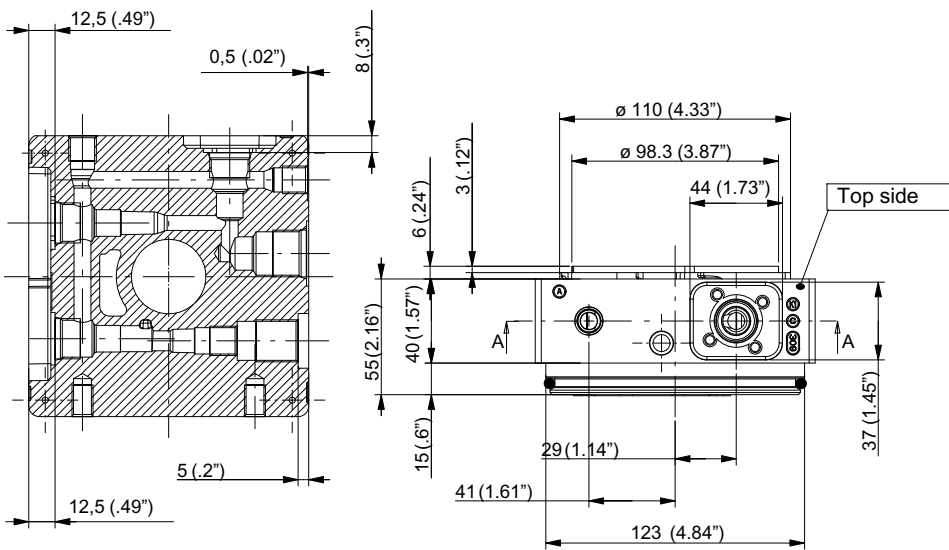

Supplied with port M plugged - Standard Version

Other versions to order

Type	Port A	Port M
UP100K1G2-01	1/4" BSP	1/4" BSP

Type	Port A	Port M
UP100K1G3-01	3/8" BSP	1/4" BSP
UP100K1M3-01	M18X1.5	1/4" BSP
UP100K1S2-01	SAE6	SAE6

Example

1	Type of housing							Vers.				
1	U	P	1	0	0	K	1	G	2	-	0	1

1.2.5 Examples for compilation of hydraulic power pack specification form

- UP100 Power pack set up for single acting circuit.
- Main work port A thread 1/4" BSP (secondary work port M with 1/4" BSP thread, plugged).
- VM01C pressure relief valve set at 150 bar
- RS3/817 check valve.
- NV1/817-R emergency valve fitted in cavity **c**.
- SDF817/22-TH (12 volt input) solenoid directional valve fitted in cavity **d**
- VRC818/05-F fixed flow control valve fitted in cavity **e**.

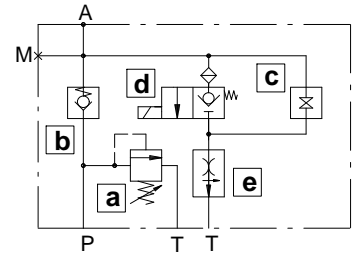

1	Type of housing										Vers.	
	U	P	1	0	0	K	1	G	2	-	0	1

7	Cavity a										Cavity b										Cavity c									
	1 5 V M 0 1 C										R S 3 / 8 1 7										N V 1 / 8 1 7 - R									
	Cavity d										Cavity e																			
	S D F 8 1 7 / 2 2 - T H										V R C 8 1 8 / 0 5 - F																			
	Cavity g										Hand lever					Lever stick					Volt									
																					1 3									

UP100 power pack with same hydraulic circuit as per above example but with:

- SDF817/22-TH solenoid directional valve fitted in cavity **c**.
- NV1/817-R emergency valve fitted in cavity **d**.

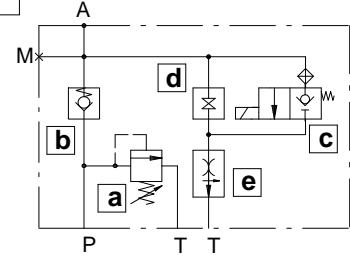

7	Cavity a										Cavity b										Cavity c									
	1 5 V M 0 1 C										R S 3 / 8 1 7										S D F 8 1 7 / 2 2 - T H									
	Cavity d										Cavity e										Cavity f									
	N V 1 / 8 1 7 - R										V R C 8 1 8 / 0 5 - F																			

- UP100 power pack set up for single acting circuit
- main work port A threaded 3/8" BSP thread (secondary work port M threaded 1/4" BSP plugged).
- VM01C pressure relief valve set at 180 bar
- RS3/817 check valve.
- ZR817/22-TV manually operated directional valve + hand lever L10 and lever stick AL001 fitted in cavity **c**
- cavity **d** plugged with T817/2 plug.
- VRC818/B-R adjustable flow control valve fitted in cavity **e**

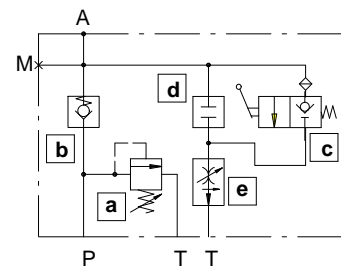

1	Type of housing										Vers.	
	U	P	1	0	0	K	1	G	3	-	0	1

7	Cavity a										Cavity b										Cavity c									
	1 8 V M 0 1 C										R S 3 / 8 1 7										Z R 8 1 7 / 2 2 - T V									
	Cavity d										Cavity e										Cavity f									
	T 8 1 7 / 2										V R C 8 1 8 / B - R																			
	Cavity g										Hand lever					Lever stick					Volt									
											L 1 0					A L 0 0 1					1 3									

1.3 Housing UP100K3 (Manifolds prearrangement or threaded P-T connections)

1.3.1 Main specification

UP100/K3P0-01

Cavity **a** = M20X1.5 (relief valve cavity)

Cavity **b** = 3/4"-16 UNF (check valve cavity)

- **P** = Pressure line for manifolds*
- **T** = Return line T for manifolds*

* for manifold see section 8

Cavities identification

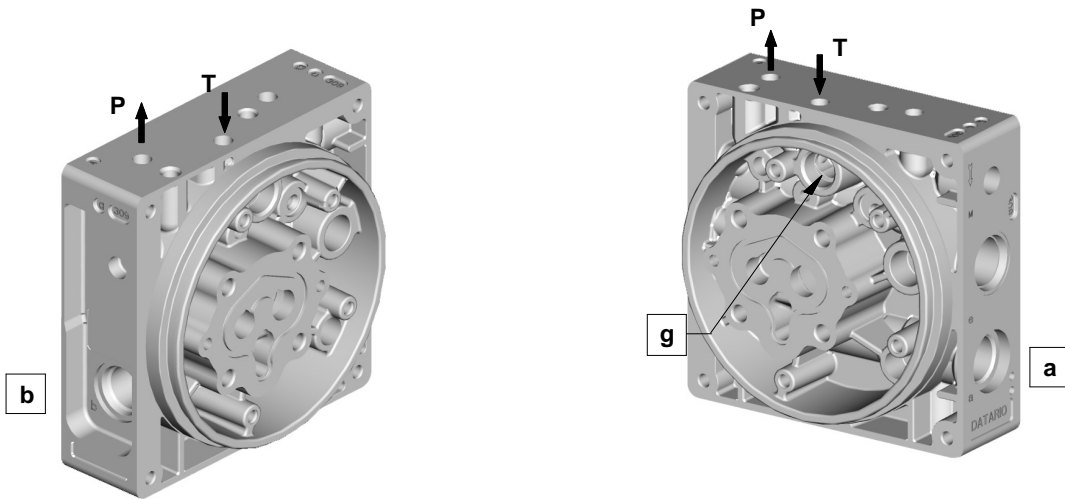
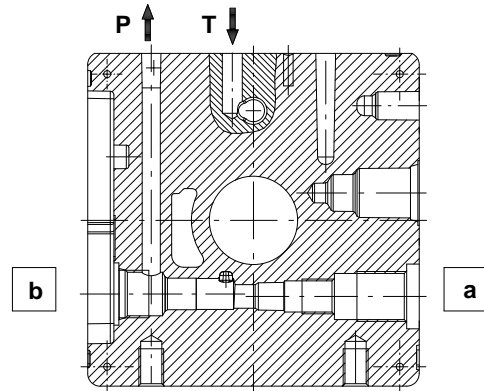

Basic circuit

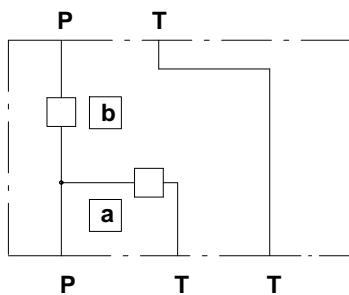

Example for standard circuit

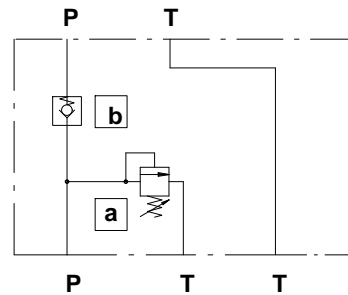

UP100K3_****

Cavity **a** = M20X1.5 (relief valve cavity)

Cavity **b** = 3/4"-16 UNF (check valve cavity)

- **P** = Threaded pressure port
- **T** = Threaded return port

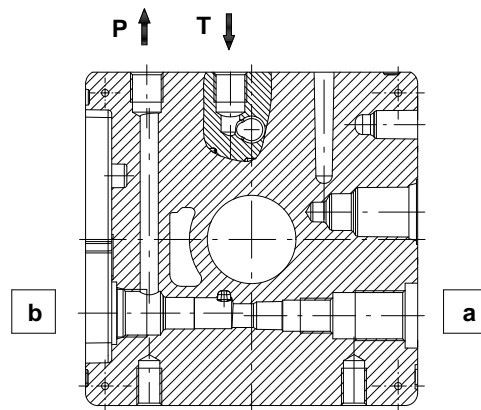

Cavities identification

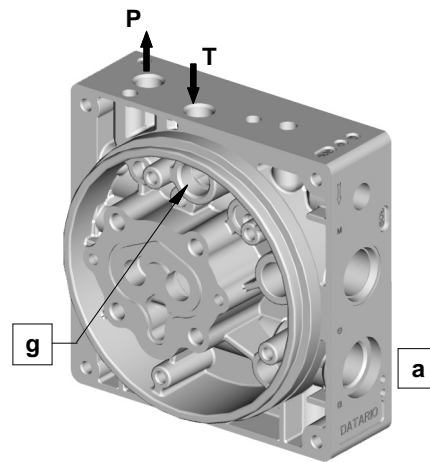
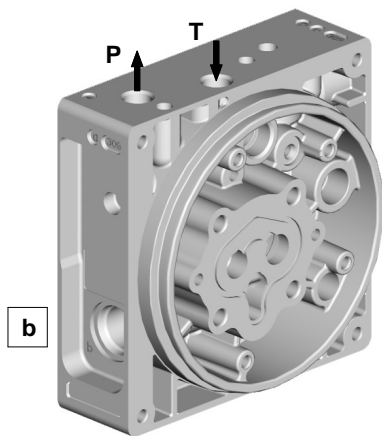

Basic circuit

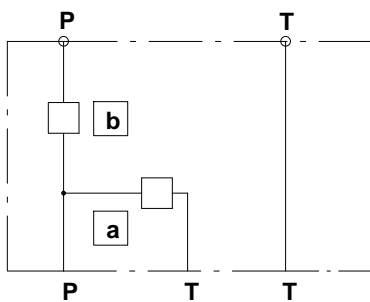

Example for standard circuit

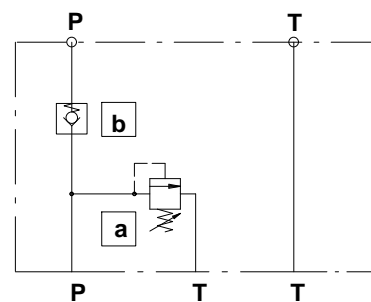

UP100K3P0-02

Cavity **a** = M20X1.5 (relief valve cavity)

Cavity **b** = 3/4"-16 UNF (check valve cavity)

Cavity **e** = 7/8"-14 UNF (flow regulator cavity)

- **P** = Pressure line P for special manifolds
- **T** = Return line T for special manifolds
- **T1** = Secondary return line T1 for special manifolds

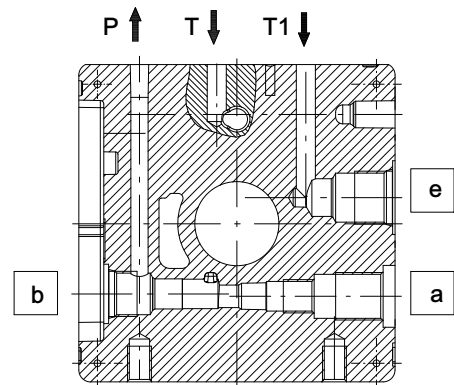

Cavities identification

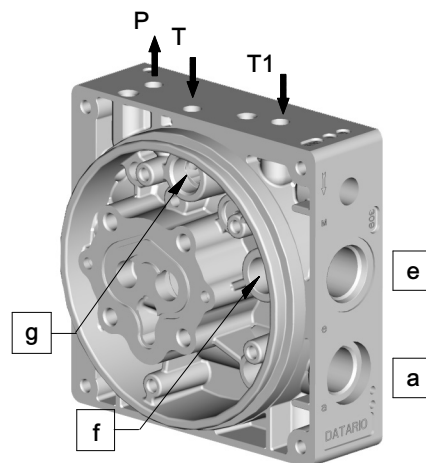
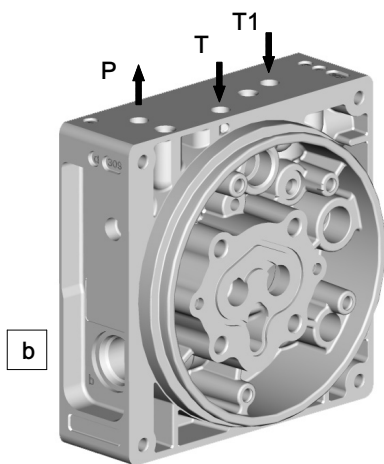

Basic circuit

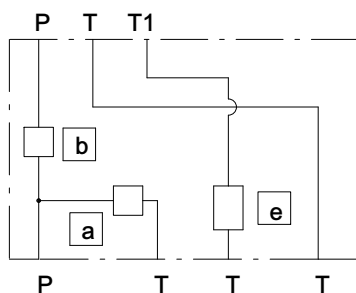

Example for a standard circuit

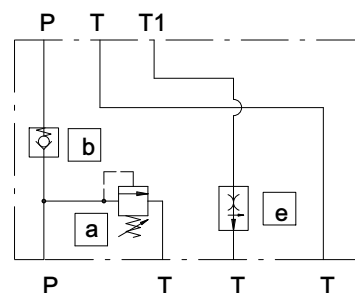

1.3.2 Component accepted by the single cavities

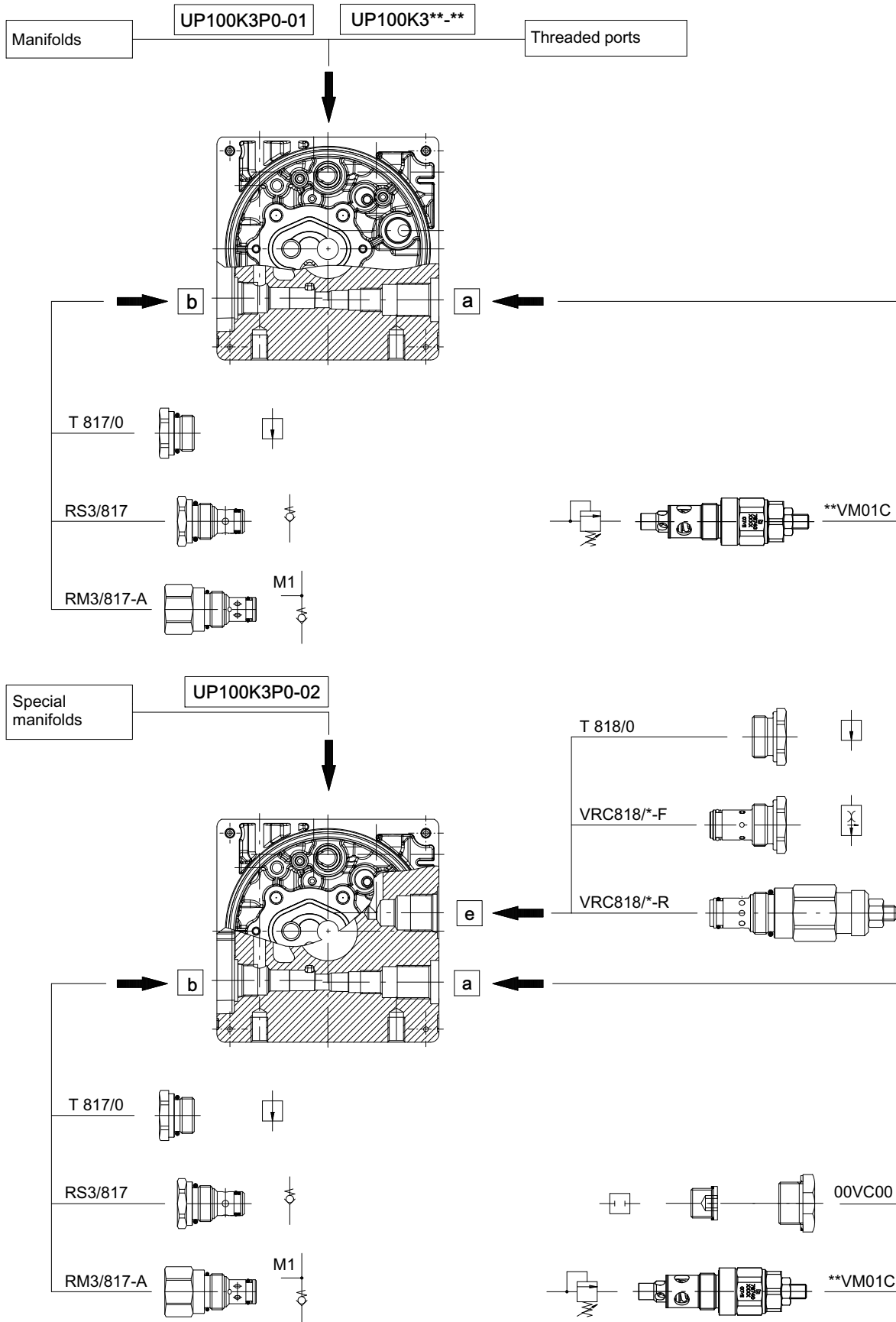

1.3.3 Dimensions

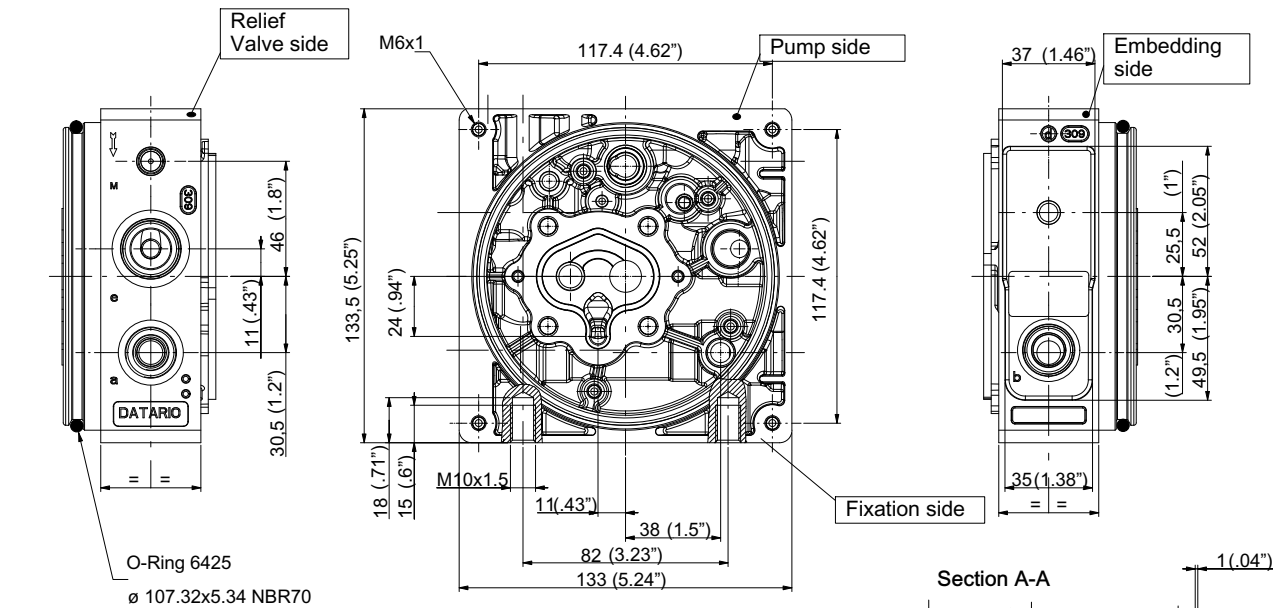

UP100/K3P0-01

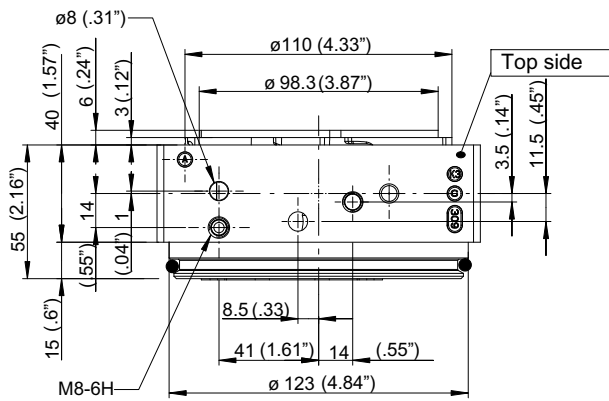

UP100/K3**_**

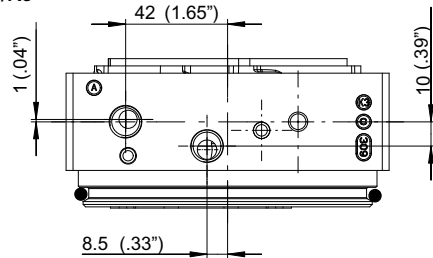

UP100/K3P0-02

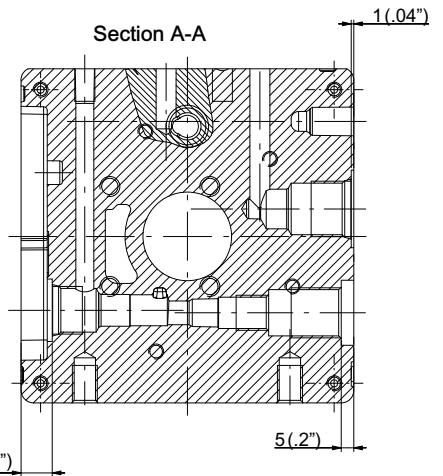
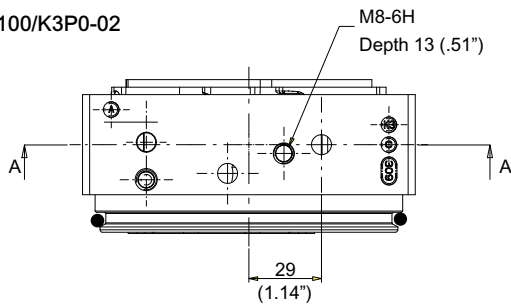

Type	For manifolds
UP100K3P0-01	Section 8 of catalogue

Type	Port P/T
UP100K3G2-01	1/4" BSP
UP100K3M2-01	M14X1.5
UP100K3S2-01	SAE6

Type	For special blocks
UP100K3P0-02	Section 8 of catalogue

Example

	Type of housing									Vers.		
1	U	P	1	0	0	K	3	P	0	-	0	1

1.4 Housing UP100K4 (integrated valves + external manifolds)

1.4.1 Main specification

UP100K4G2-01

Cavity **a** = M20X1.5 (relief valve cavity)

Cavity **b** = 3/4"-16 UNF (check valve cavity)

Cavity **d** = 3/4"-16 UNF (directional valve cavity)

Cavity **e** = 7/8"-14 UNF (flow regulator cavity)

- **P** = Threaded pressure port

- **T** = Threaded return port

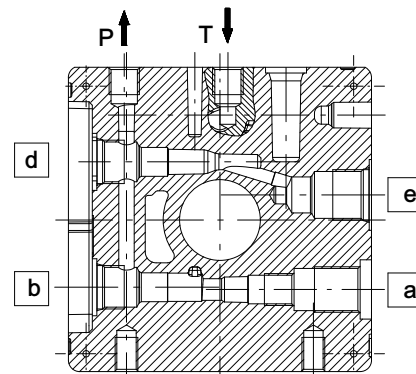

Cavities identification

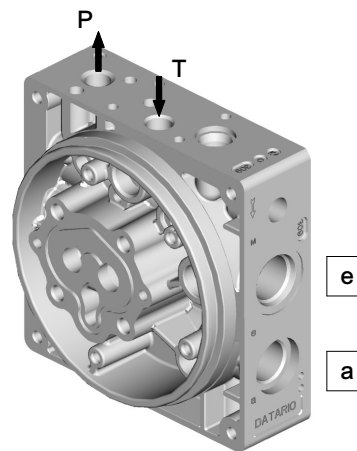
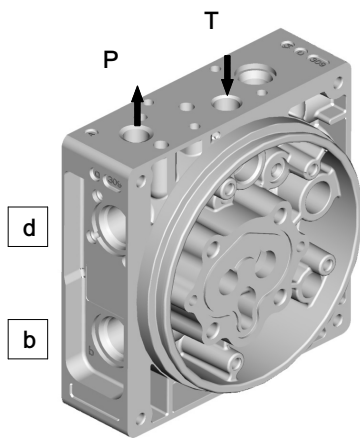

Basic circuit UP100K4G2-01

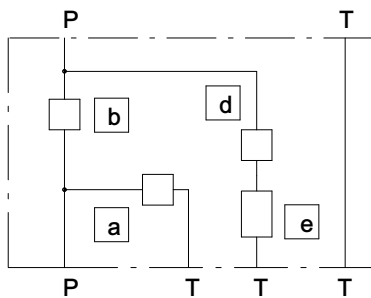

Example for a standard circuit UP100K4G2-01

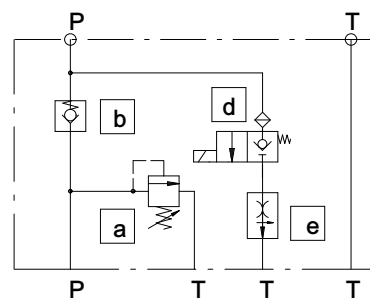

UP100K4P0-01

Cavity **a** = M20X1.5 (relief valve cavity)

Cavity **b** = 3/4"-16 UNF (check valve cavity)

Cavity **d** = 3/4"-16 UNF (directional valve cavity)

Cavity **e** = 7/8"-14 UNF (flow regulator cavity)

- **P** = Pressure line for manifolds

- **T** = Return line for manifolds

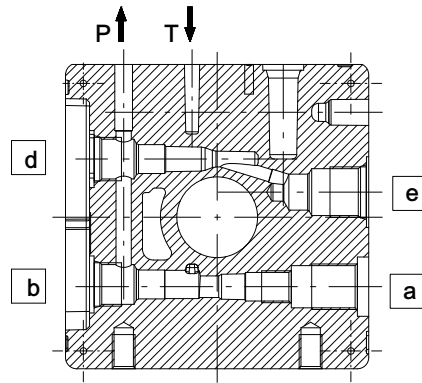

Cavities identification

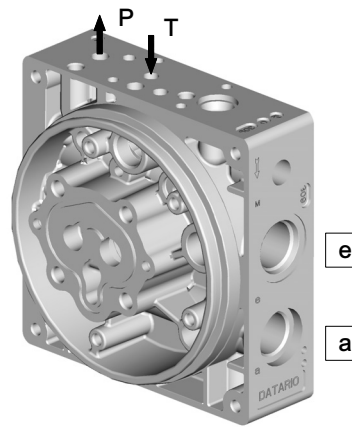
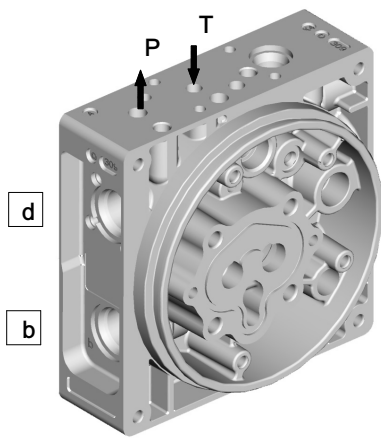

Basic circuit

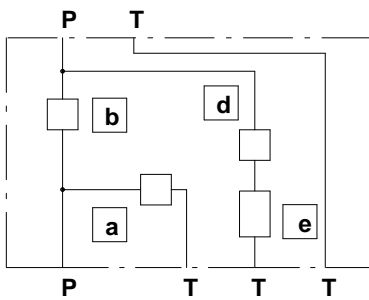

Example for a standard circuit

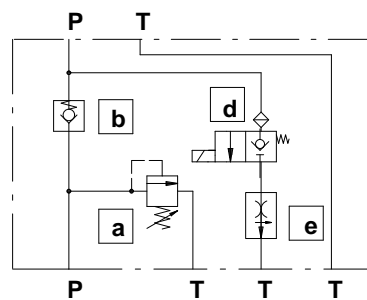

UP100K4D0-01 / UP100K4D0-02

Cavity **a** = M20X1.5 (relief valve cavity)

Cavity **b** = 3/4"-16 UNF (check valve cavity)

- **P** = Pressure line for directional valves
- **T1** = Return line for directional valves
- **T2** = Secondary return line T2 for directional valves* (Plugged in UP100/K4D002 version)

* for directional valves see section 9

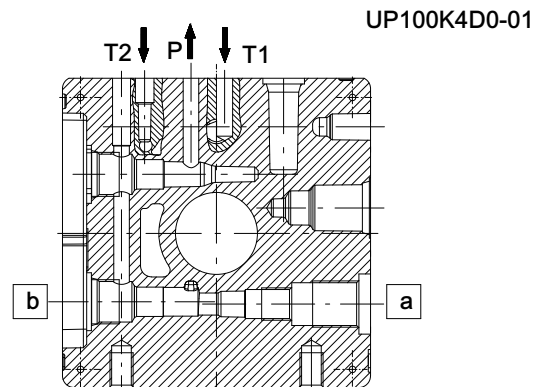
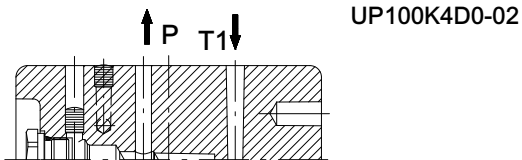

Cavities identification

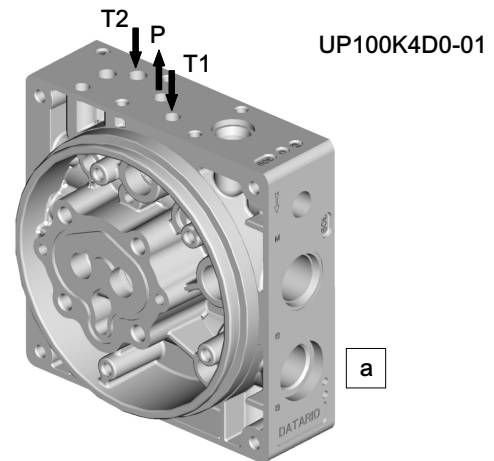
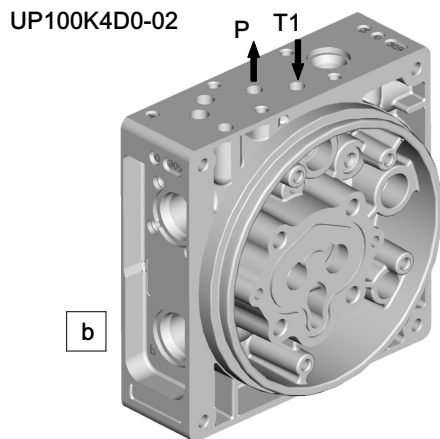

Example for a standard circuit UP100K4D0-02

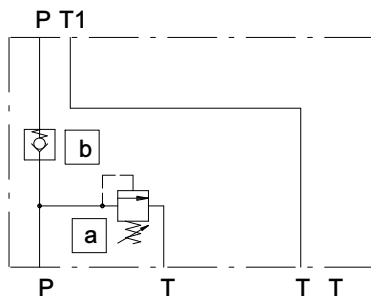

Example for a standard circuit UP100K4D0-01

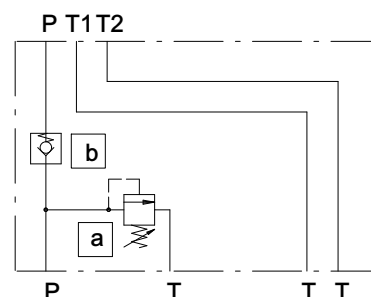

1.4.2 Components accepted by the single cavities

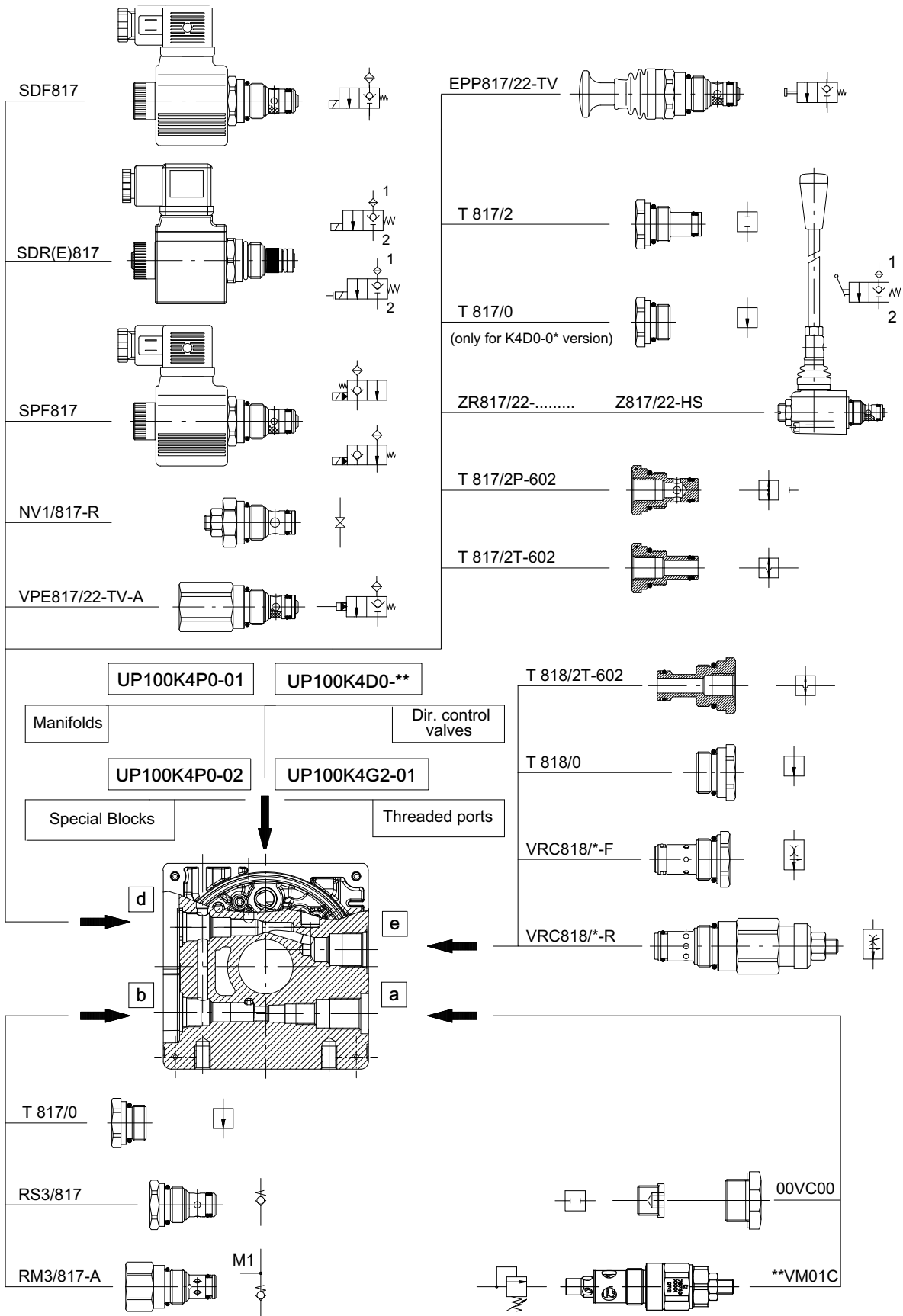

1.4.3 Dimensions

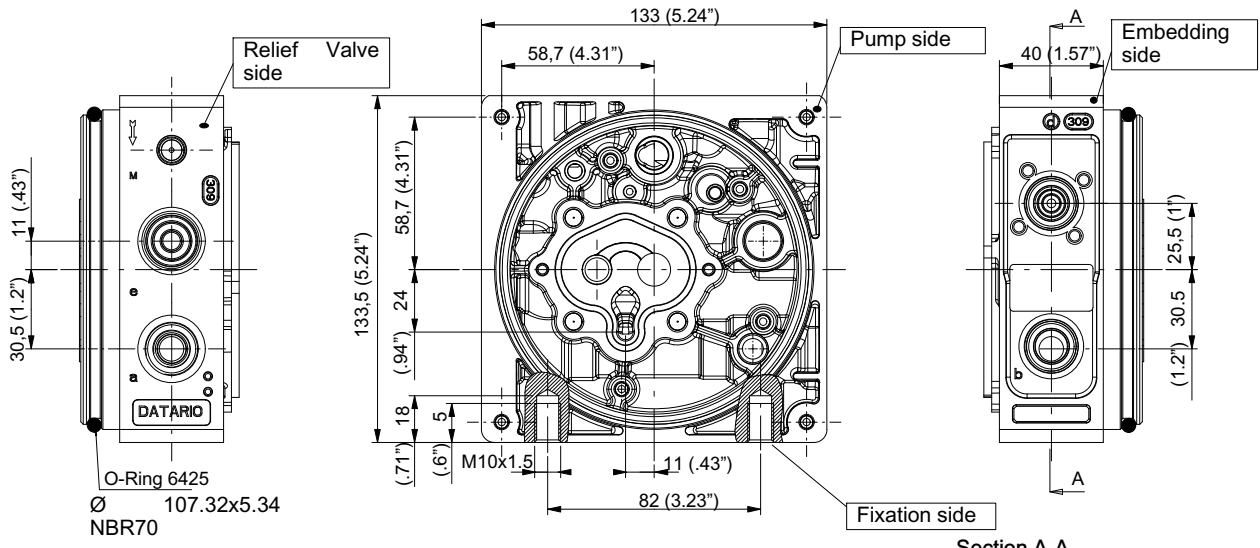

Section A-A

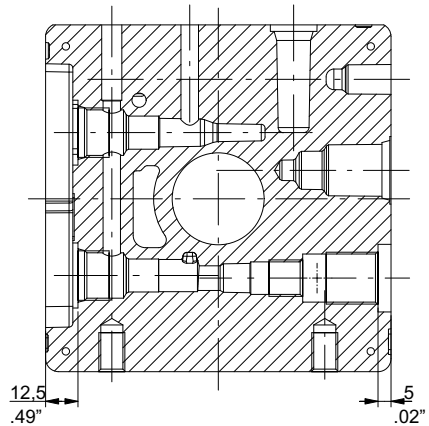

UP100K4D0-0*

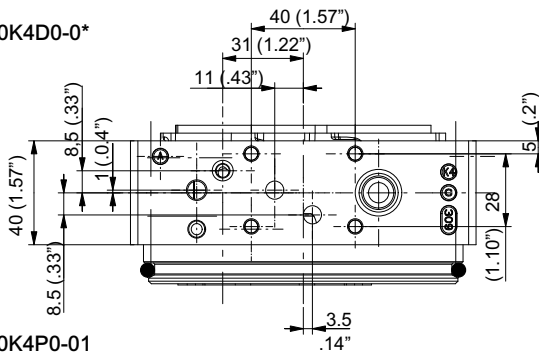

UP100K4P0-01

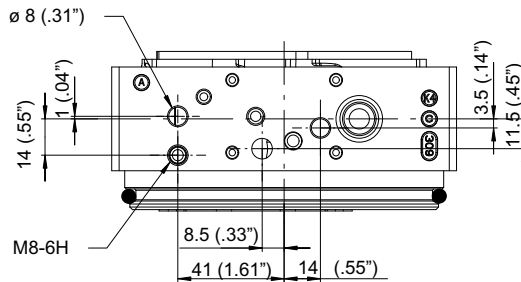

JP100K4*2-01

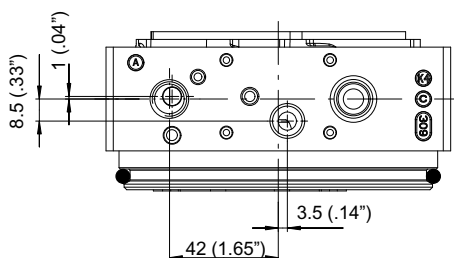

Type	For directional control valves
UP100K4D0-01	Plates 4270-4280 for HDS11-HDS07
UP100K4D0-02	HD105-HD106

Type	For manifolds
UP100K4P0-01	Section 8 of catalogue

Type	Port P/T
UP100K4G2-01	1/4" BSP
UP100K4M2-01	M14X1.5
UP100K4S2-01	SAE6

Example

	Type of housing	Vers.
1	U P 1 0 0 K 4 P 0 - 0 1	

1.4.4 Example for compilation of hydraulic power pack specification form

- UP100 Power pack with integrated valves and prearranged for external manifold
- VM01C pressure relief valve set at 180 bar
- RS3/817 check valve.
- SDF817/22-TH solenoid operated directional valve (12 V. D.C.) fitted in cavity d.
- VDF818/09-F fixed flow control valve fitted in cavity e.

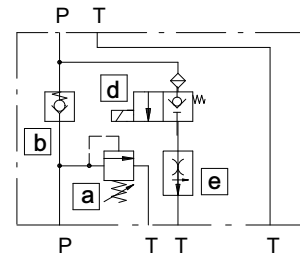

Type of housing		Vers.	
1	U P 1 0 0 K 4 P 0 - 0 1		
7	Cavity a	Cavity b	Cavity c
	1 8 V M 0 1 C	R S 3 / 8 1 7	
	Cavity d	Cavity e	Cavity f
S D F 8 1 7 / 2 2 - T H	V R C 8 1 8 / 0 9 - F		
Cavity g	Hand lever	Lever Stick	Volt
			1 3

- UP100 power pack with integrated valves and threaded connections P/T= 1/4" BSP and T1= 3/8" BSP.
- VM01C pressure relief valve set at 210 bar
- RS3/817 check valve.
- SDF817/22-TH solenoid operated directional valve (24 volt 50 Hz A.C.).
- VRF818/05-F fixed flow control valve fitted in cavity e.

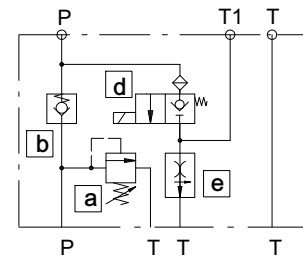

Type of housing		Vers.	
1	U P 1 0 0 K 4 G 2 - 0 4		
7	Cavity a	Cavity b	Cavity c
	2 1 V M 0 1 C	R S 3 / 8 1 7	
	Cavity d	Cavity e	Cavity f
S D F 8 1 7 / 2 2 - T H	V R C 8 1 8 / 0 5 - F		
Cavity g	Hand Lever	Stick Lever	Volt
			2 1

UP100 power pack prearranged for external directional control valves.

- VM01C pressure relief valve set at 210 bar.
- RS3/817 check valve.
- HD106 K02 ADC08 manual operated directional valve fitted on UP100 housing.

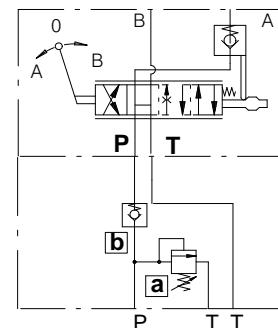

Type of housing		Vers.					
1	U P 1 0 0 K 4 D 0 - 0 2						
7	Cavity a	Cavity b	Cavity c				
	2 1 V M 0 1 C	R S 3 / 8 1 7					
	El. n.	Sectional body valve	Circuit	Posit.	Lever	Hand Lever	Valves for sect. valve
9	1	H D 1 0 6	K 0 2	A D C 0 1	L 1 0 0	A L 0 0 1	

1.5 Housing UP100K6 (Single acting)

1.5.1 Main specification

Cavity **a** = M20X1.5 (relief valve cavity)

Cavity **b** = 3/4"-16 UNF (check valve cavity)

Cavity **c** = 3/4"-16 UNF (directional valve cavity)

Cavity **e** = 7/8"-14 UNF (flow regulator cavity)

Cavity **f** = return line

- **A** = Main work port

- **M** = Secondary work port

One only possible assembling position for the directional valve

Three possible flow range capacity (8-14-25 lt/1') for the solenoid directional control valve.

Cavities identification

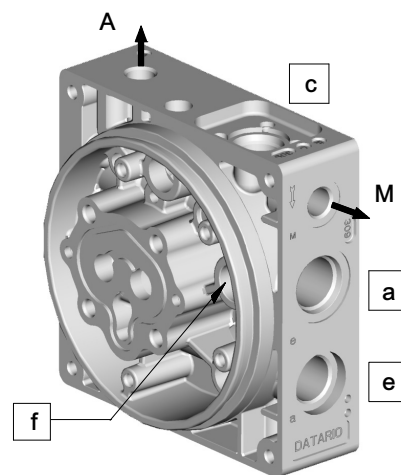
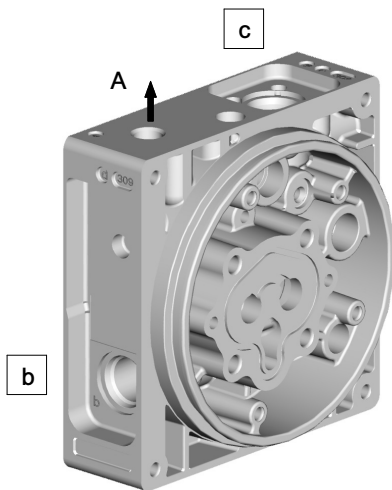
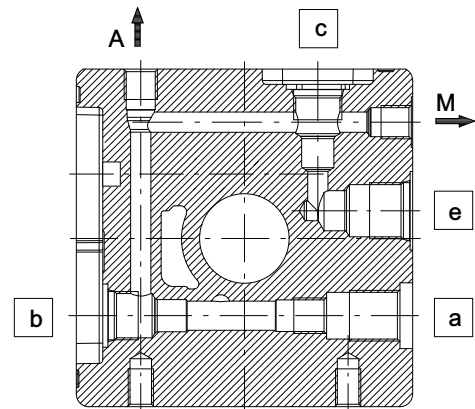

Basic circuit

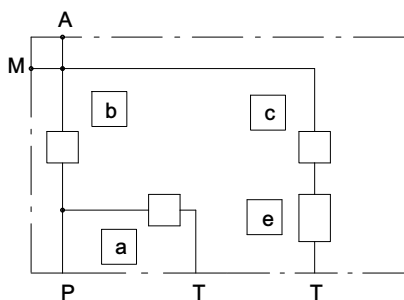

Example for a standard circuit

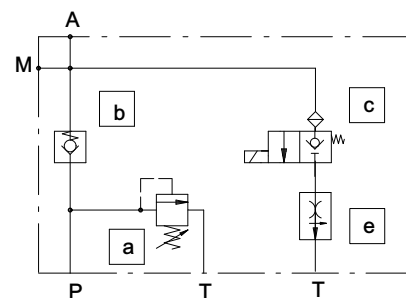

1.5.2 Component accepted by the single cavities

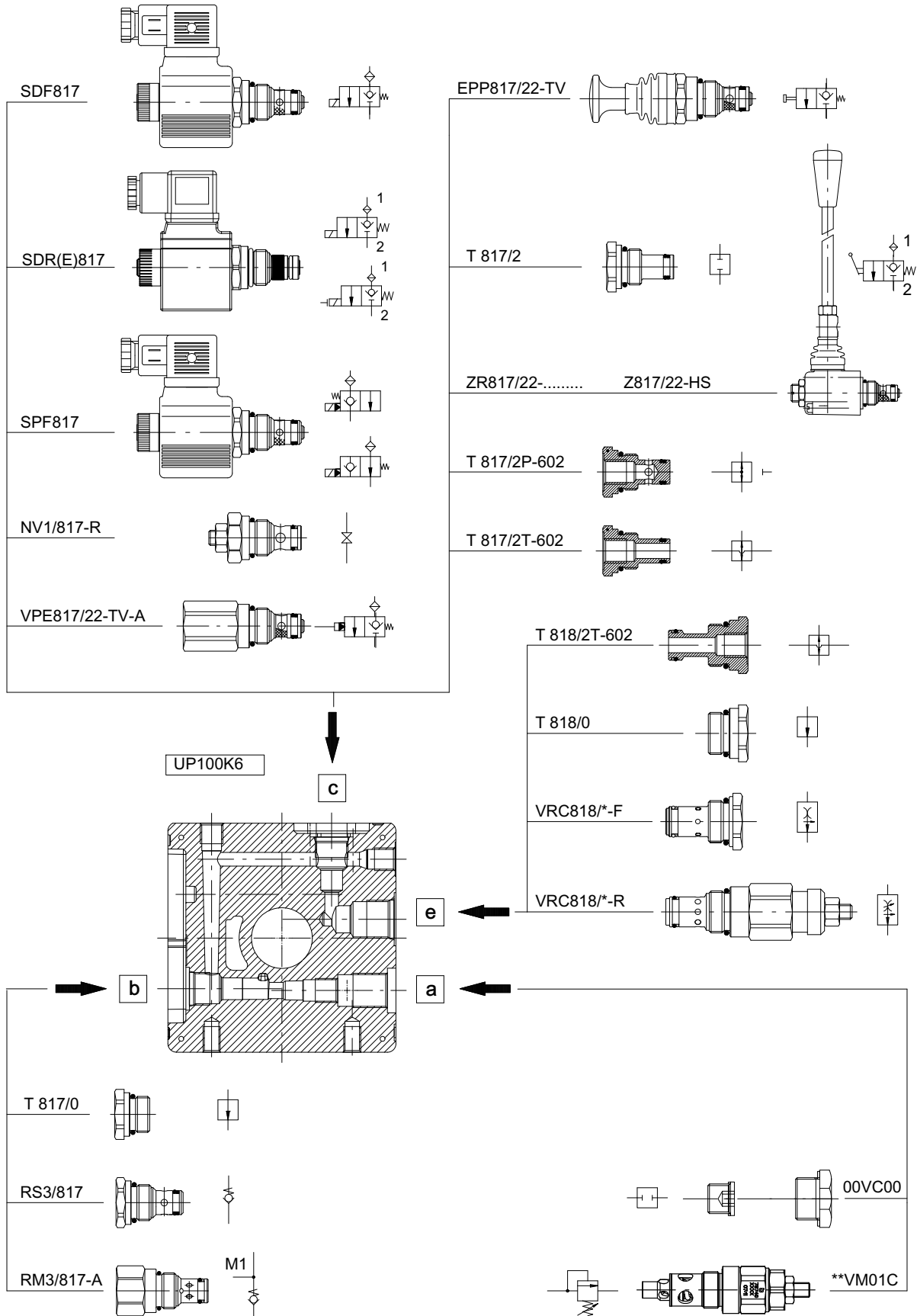

1.5.3 Dimensions

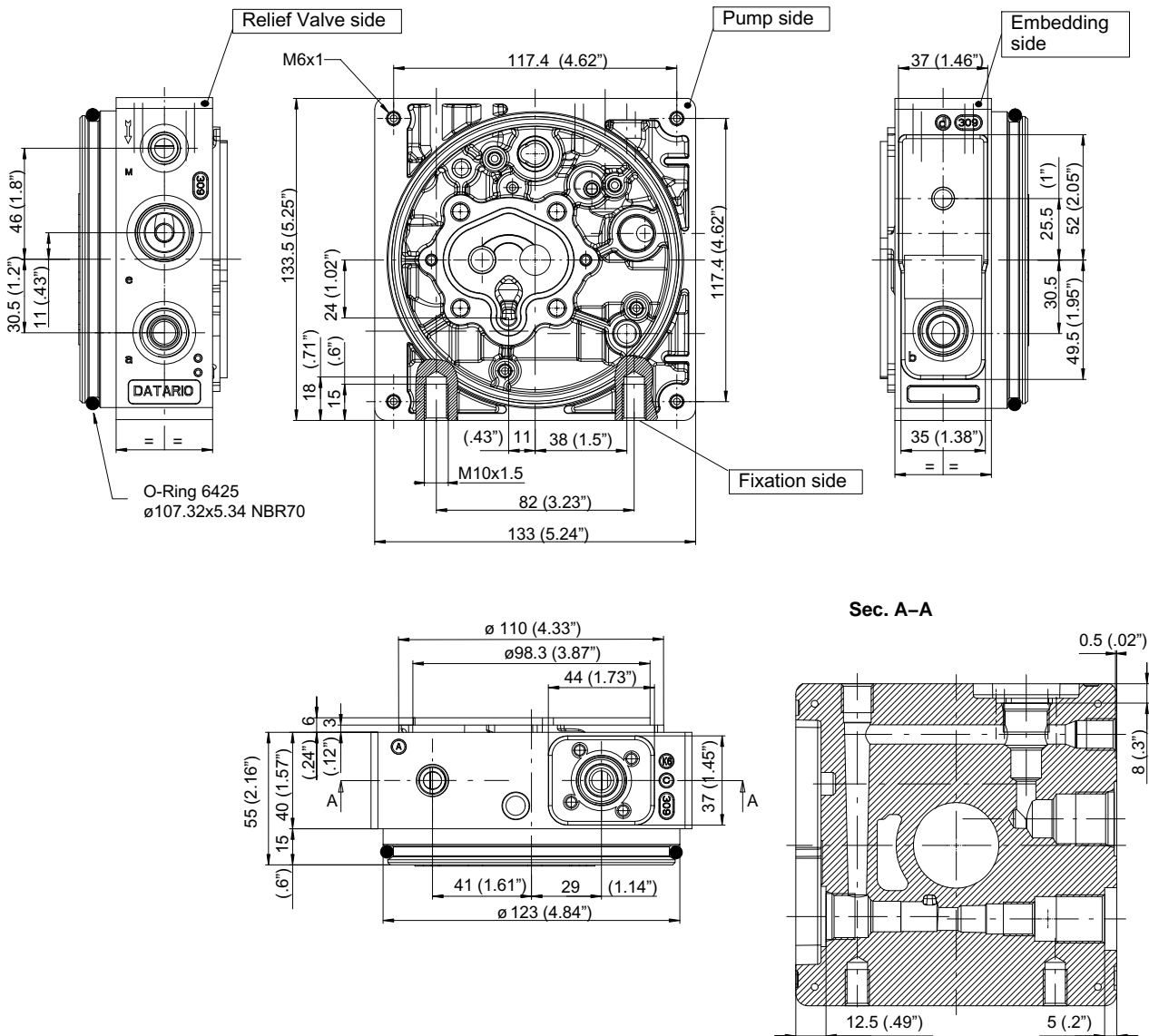

Supplied with port M plugged - Standard Version

Type	Port A	Port M
UP100K6G2-01	1/4" BSP	1/4" BSP

Other versions to order

Type	Port A	Port M
UP100K6G3-01	3/8" BSP	1/4" BSP
UP100K6S2-02	SAE6	SAE6

Example

	Type of housing										Vers.	
1	U	P	1	0	0	K	6	G	2	-	0	1

1.5.4 Examples for compilation of hydraulic power pack specification form

- UP100 Power pack set up for single acting circuit.
Main work port A thread 1/4" BSP (secondary work port M threaded 1/4" BSP plugged)
- VM01C pressure relief valve set at 150 bar
- RS3/817 check valve.
- SDF817/22-TH solenoid operated directional valve (12 VDC) fitted in cavity c.
- VRC818/05-F fixed flow control valve fitted in cavity e.

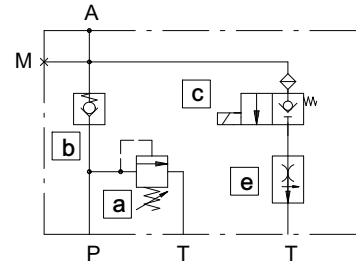

Type of housing		Vers.										
1	U P 1 0 0 K 6 G 2 - 0 1											
7	Cavity a			Cavity b			Cavity c					
	1 5 V M 0 1 C			R S 3 / 8 1 7			S D F 8 1 7 / 2 2 - T H					
	Cavity d			Cavity e								
				V R C 8 1 8 / 0 5 - F								
Cavity g			Hand lever			Lever stick			Volt			
									1 3			

- UP100 power pack set up for single acting circuit.
Main work port A with 3/8" BSP thread (secondary work port M with 1/4" BSP thread plugged).
- VM01C pressure relief valve set at 180 bar
- RS3/817 check valve.
- ZR817/22-TV manual operated directional valve fitted in cavity c.
- VRC818/B-R adjustable flow control valve fitted in cavity e.

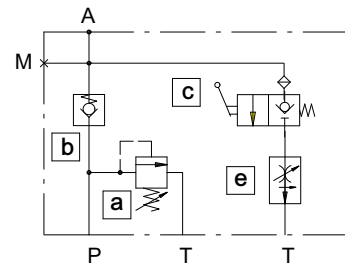

Type of housing		Vers.										
1	U P 1 0 0 K 6 G 3 - 0 1											
7	Cavity a			Cavity b			Cavity c					
	1 8 V M 0 1 C			R S 3 / 8 1 7			Z R 8 1 7 / 2 2 - T V					
	Cavity d			Cavity e						Cavity f		
				V R C 8 1 8 / B - R								
Cavity g			Hand lever			Lever stick			Volt			
			L 1 0			A L 0 0 1						

1.6 Preassembled housings

The table summarizes part number to be stated in the event that is wished to order the housing sub-assembly fitted with shaft seal only. Remember that the preassembled housing

is supplied without the O-Rings kit, which must be ordered separately.

Preassembled housing K1-K3-K4-K6 with shaft seal

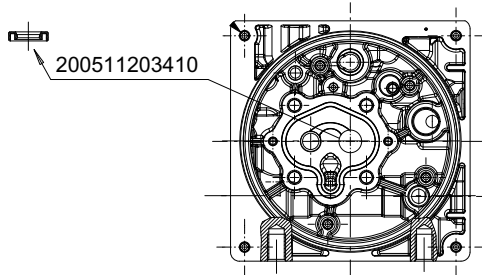

O-Rings kit 200974200400

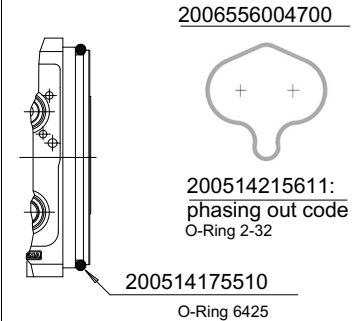

	Body type	Code
K1	UP100 K1G2-01	200740431021
	UP100 K1G3-01	200740431141
	UP100 K1G2-19	200740431471
	UP100 K1M3-01	200740431620
K3	UP100 K3P0-01	200740410531
	UP100 K3P0-02	200740410541
	UP100 K3G2-01	200740420071
	UP100 K3S2-01	200740420101

	Body type	Code
K4	UP100 K4G2-01	200740420111
	UP100 K4P0-01	200740410561
	UP100 K4D0-01	200740440321
	UP100 K4D0-02	200740440321
K6	UP100 K6G2-01	200740431381
	UP100 K6G3-01	200740431391
	UP100 K6S2-02	200740431401

Preassembled housing K1-K3-K4-K6 with shaft seal, relief and check valve

Pressure relief valve with setting range 96-220 bar (green spring).
For other values, order the different springs separately
See: section 7.2 - Cartridge valves

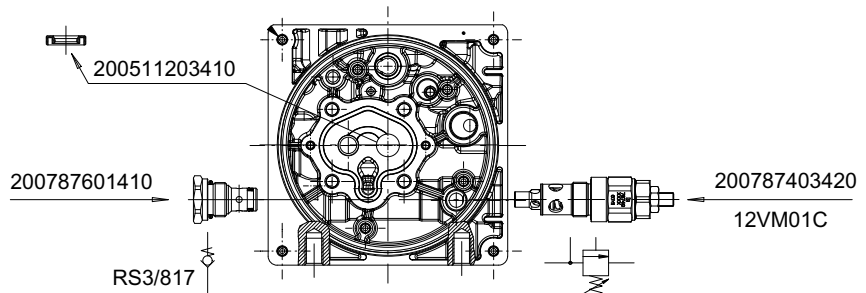

	Body type	Code
K1	UP100 K1G2-01	200740430681
	UP100 K1G3-01	200740430661
	UP100 K1G2-19	200740431481
K3	UP100 K3P0-01	200740410381
	UP100 K3P0-02	200740410411
	UP100 K3G2-01	200740410421
	UP100 K3S2-01	200740420061

	Body type	Code
K4	UP100 K4G2-01	200740410431
	UP100 K4P0-01	200740410401
	UP100 K4D0-01	200740440251
	UP100 K4D0-02	200740440261
K6	UP100 K6G2-01	200740431411
	UP100 K6G3-01	200740431421
	UP100 K6S2-02	200740431431

2 Gear pumps

2.1 Technical information

2.1.1 Material

Cover: Pressure diecast aluminium alloy
GdAlSi12Cu2Fe to EN-AB 46100 (UNI5076)
Intermediate flange for HI-LO pump: gravity diecast
aluminium alloy AlSi10Mg(Cu) to EN-AB 43200
(UNI1706).
Body: Extruded aluminium alloy P-AlZn5.8Mg0.8Zr

to EN AW-7003 (UNI9007/6)
Gears: Casehardened and hardened steel
20MnCrS 60 HRC.
Bearings: special SICAL3 antifriction alloy.
Seals: Polyamides NBR.
Backup ring: ZYTEL E10 3HS.

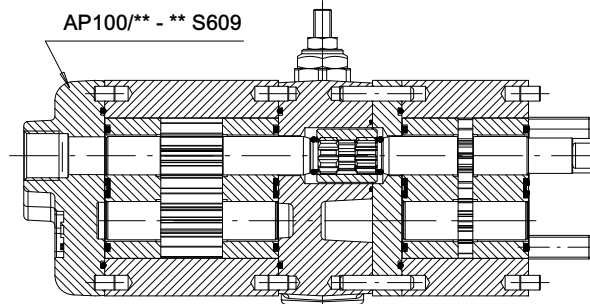
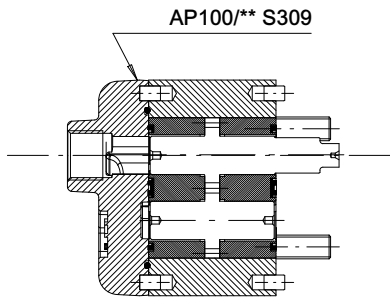

2.1.2 Suitable fluids

Only mineral oil based hydraulic fluids responding to ISO/
DIN standard should be used.

Viscosity range:

- recommended 20 - 120 mm²/s (cSt)
- admitted up to 700 mm²/s (cSt)

Operating temperature range: -15 +80 °C

For other fluids consult our Sales Department.



Attention: Use of pumps at temperatures above
80°C must always be agreed upon with our Techni-
cal Office, and in any case this can cause a signifi-
cant worsening in the volumetric efficiency. For
use under conditions different from those indicated
in this catalogue, please contact our Sales Depart-
ment.

2.1.3 Inlet

Absolute pressure at the pump inlet must be

$$V > 0.75 \text{ bar (11 PSI)}$$

Accordingly, avoid:

- significant differences in height of pump and tank
- long pipeline runs
- sharp bends, restrictions, etc. causing turbulent flow

In certain applications, inlet pressure may be higher than 1
bar (14.3 PSI), or at any rate higher than atmospheric. For
pumps with standard configuration, the pressure register-
ing at the gauge M1 should be:

$$M1 < 3.5 \text{ bar (50 PSI)}.$$

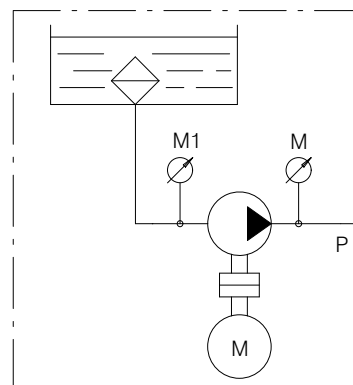
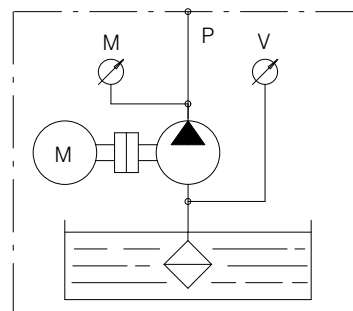

2.1.4 Outlet

Pressure levels:

P1 = continuous operating pressure

P2 = intermittent operating pressure

P3 = peak pressure

The recommended delivery pipe oil speed is between:

$$v = 2 - 5 \text{ m/s}$$

In the next pages are indicated the performances for each pump.

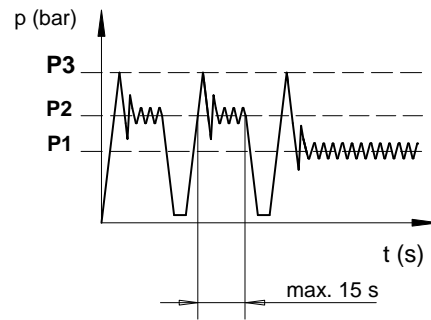

Example of the values in the table

AP100 Pump type	Displacement		L		Max pressure						n min.	n max.
	cm ³ / rev	Cu.In. P.R.	mm	inch.	P1		P2		P3			
					bar	PSI	bar	PSI	bar	PSI		
AP100/2.5 S309	2.5	.152	86.4	3.40	210	3000	230	3300	250	3600	650	5000

2.1.5 Calculating the specifications of a gear pump

The equations for calculating the following parameters are given below:

V_c = (cm³/g) pump displacement;

n = (g/min) Drive shaft rpm;

Q = (l/min) flow rate;

P = (bar) Operating pressure;

M = (Nm) Torque;

N = (kW) Power

η_v = (%) Volumetric efficiency

η_m = (%) Mechanical efficiency

η_t = (%) Total efficiency

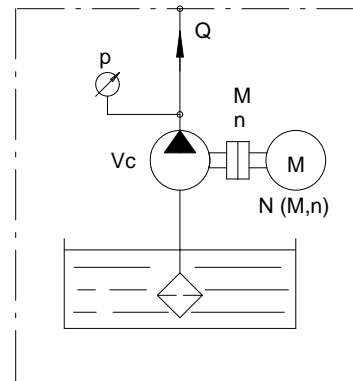

$$Q = \frac{V_c \cdot n}{100000} \cdot \eta_v$$

$$V_c = \frac{100000 \cdot Q}{n \cdot \eta_v}$$

$$n = \frac{100000 \cdot Q}{V_c \cdot \eta_v}$$

$$N = \frac{V_c \cdot n \cdot p}{6120 \cdot \eta_m}$$

$$N = \frac{Q \cdot p}{6.12 \cdot \eta_t}$$

$$p = \frac{N \cdot 6.12 \cdot \eta_t}{Q}$$

$$p = \frac{N \cdot 6120 \cdot \eta_m}{V_c \cdot n}$$

$$M = 9555 \cdot \frac{N}{n}$$

$$\eta_t = \eta_v \cdot \eta_m$$

Example

AP100/2.5 $V_c = 2.5 \text{ cm}^3/\text{r}$ $n = 1500 \text{ r/min}$ $p = 200 \text{ bar}$ $\eta^v = 94\%$ $\eta^m = 87\%$

$$Q = \frac{2.5 \cdot 1500}{100000} \cdot 94 = 3.52 \text{ l/min.}$$

$$\eta_t = 0.94 \cdot 0.87 = 0.82 = 82\%$$

$$N = \frac{3.52 \cdot 200}{6.12 \cdot 82} = 1.4 \text{ kW}$$

$$M = 9555 \cdot \frac{1.4}{1500} = 9 \text{ Nm}$$

2.2 Single unidirectional pumps - Counterclockwise rotation

AP100/** - S309

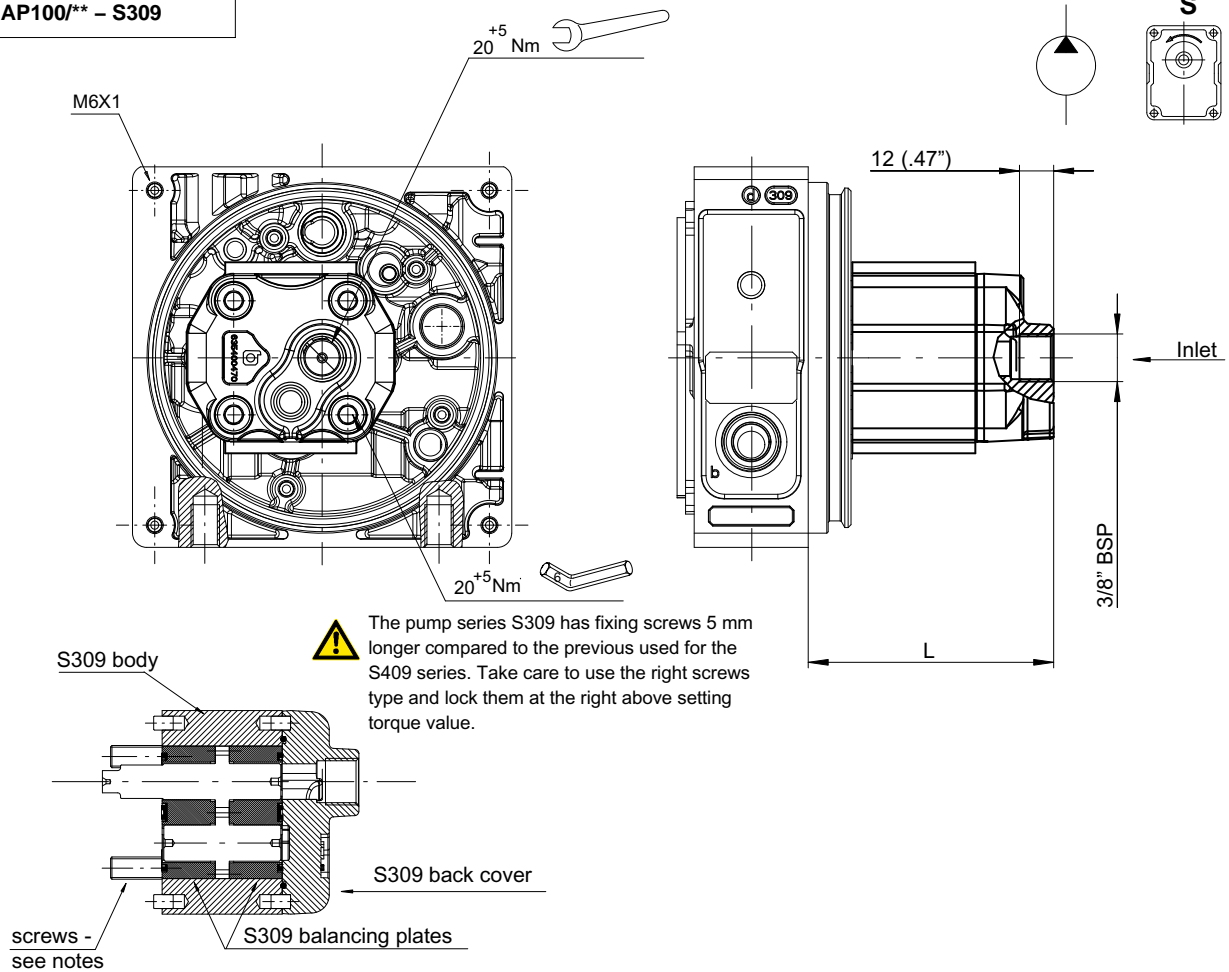

Example

Pump

Hi-Lo

Series

O-Ring replacement kit: 200974001450

2	A	P	1	0	0	/	2	,	5					S	3	0	9
---	---	---	---	---	---	---	---	---	---	--	--	--	--	---	---	---	---

Displacement		AP100		L		Max. pressure						n. min.	n. max
cm ³ /rev	Cu.InP. R.	Pump type	Order code	mm	inch	P1		P2		P3			
						bar	PSI	bar	PSI	bar	PSI		
1.2	.073	AP100/1.2 S309	200748210270	86.1	3.39	210	3000	230	3300	250	3600	800	5000
1.7	.103	AP100/1.7 S309	200748220230	88.1	3.47	210	3000	230	3300	250	3600	650	5000
2.5	.152	AP100/2.5 S309	200748230340	91.4	3.60	210	3000	230	3300	250	3600	650	5000
3.5	.213	AP100/3.5 S309	200748240240	95.7	3.77	210	3000	230	3300	250	3600	650	4000
4.3	.262	AP100/4.3 S309	200748250160	99.3	3.91	210	3000	230	3300	250	3600	550	4000
5.0	.305	AP100/5 S309	200748260230	102.1	4.02	210	3000	230	3300	250	3600	500	3500
6.5	.396	AP100/6.5 S309	200748270260	107.1	4.22	190	2700	220	3150	240	3400	500	3000
7.8	.476	AP100/8 S309	200748280130	112.7	4.44	180	2600	210	3000	230	3300	500	3000
10	.610	AP100/10 S309	200748290800	121.8	4.79	150	2150	180	2600	200	2900	500	2500



Attention: Use of pumps at temperatures above 80°C must always be agreed upon with our Technical Office, and in any case this can cause a significant worsening in the volumetric efficiency.

For use under conditions different from those indicated in this catalogue, please contact our Sales Department

2.3 Double pumps with HI-LO valve - Counterclockwise rotation



The pump series S609 has fixing screws 5 mm longer compared to the previous used for the S509 series. Take care to use the right screws type and lock them at the right below setting torque value.

AP100/** - **S609

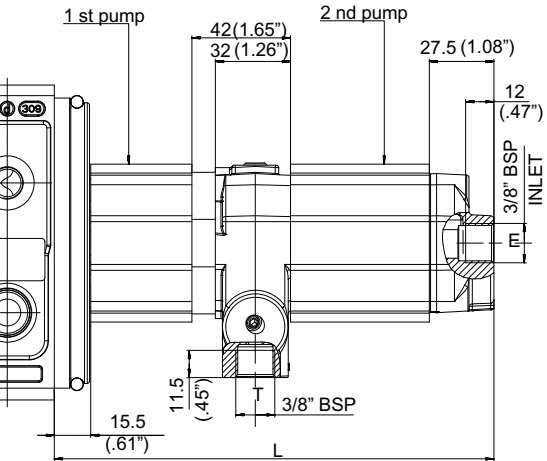
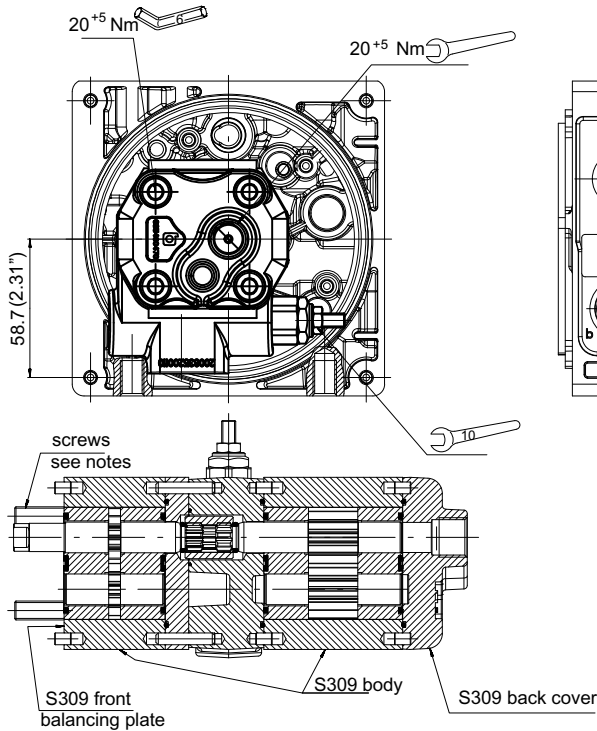
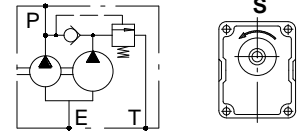

Standard setting values for HI-LO valve
 03 = 30 bar (spring with adjustment range from 15 - 55 bar)
 06 = 60 bar (spring with adjustment range from 55 - 90 bar)

Example

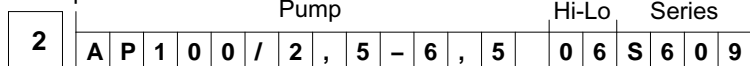

1st pump 2nd pump Setting Valve

O-Ring replacement kit: 200974001431

1st Pump		2nd Pump		AP100		L Dimension		Existing code		Pressure Setting (bar)
cm ³ /rev	Cu. In. P.R.	cm ³ /rev	Cu. In. P.R.	1st Pump	2nd Pump	mm	inch	Order code	Description	
1.2	.073	4.3	.262	AP100/1.2	AP100/4.3	184.5	7.26	200111194314	AP100/1,2-4,3.03 S609	30
1.2	.073	5.0	.305	AP100/1.2	AP100/5	187	7.36	200111194311	AP100/1,2-5,0.08 S609	80
1.2	.073	6.5	.396	AP100/1.2	AP100/6.5	192	7.56			
1.2	.073	7.8	.476	AP100/1.2	AP100/8	198	7.80	200111194312	AP100/1,2-8,0.03 S609	30
1.7	.103	4.3	.262	AP100/1.7	AP100/4.3	186.5	7.34			
1.7	.103	5.0	.305	AP100/1.7	AP100/5	189	7.44	200111294309	AP100/1,7-5,0.06 S609	60
1.7	.103	6.5	.396	AP100/1.7	AP100/6.5	194	7.64			
1.7	.103	7.8	.476	AP100/1.7	AP100/8	200	7.87			
2.5	.153	4.3	.262	AP100/2.5	AP100/4.3	189.5	7.46			
2.5	.153	5.0	.305	AP100/2.5	AP100/5	192.5	7.58			
2.5	.153	6.5	.396	AP100/2.5	AP100/6.5	197.5	7.78			
2.5	.153	7.8	.476	AP100/2.5	AP100/8	203	7.99	200111394308	AP100/2,5-8,0.05 S609	50
3.5	.215	5.0	.305	AP100/3.5	AP100/5	197	7.76			
3.5	.215	6.5	.396	AP100/3.5	AP100/6.5	202	7.95	200111494312	AP100/3,5-6,5.06 S609	60
3.5	.215	7.8	.476	AP100/3.5	AP100/8	207.5	8.17			

N.B.: Please contact our Sales Department if even one of the operating limits indicated in the tables above (temperature, pressure, rpm) is exceeded, as well as in the case of two or more maximum values at the same time, or for applications with particularly heavy-duty cycles.

Note (*): For availability of pumps without ordering code please contact our Sales Department.

3 Tanks

Tanks supplied by Bucher Hydraulics S.p.A. are classified in two families, according to the material used in manufacture:

3.1 Plastic tanks

3.2 Metal tanks

For both following our fixing system

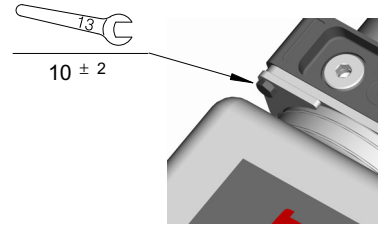

For the correct number of fixing bracket, bracket spacers and fixing bolts, see "Notes of fitment" of each Tank families

3.1 Plastic tanks

3.1.1 Technical information

Material: Polypropylene (PP)

Color: neutral, translucent allowing visual check on the oil level

Density: 0.9 Kg/dm³

Conditions of use:

Operating temperature range: -15 / +70°C

Suitable fluids: use only mineral oil based hydraulic fluids responding to ISO - DIN standards.

Hydrocarbon based fluids (e.g. benzene, benzol, etc.) must not be used.

Versions: Tank are available in numerous versions, allowing installation of the power pack in different horizontal and vertical positions.



Attention: Whilst the fixing and sealing systems are designed for operation under the most heavy-duty conditions, the tank must be securely anchored when fitted to mobile equipment, and when subject to shocks and heavy vibrations generally, by means of flexible clips located in the recesses provided. Care must be taken never to stress and deform the tank when tightening the anchorages.

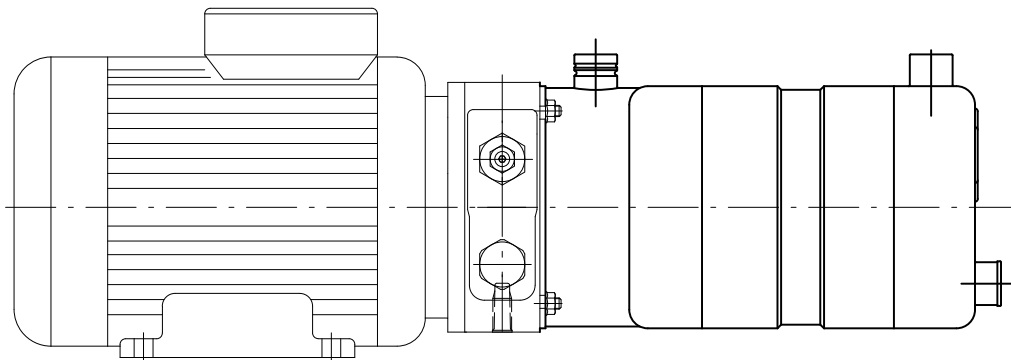

Guideline capacity values:

Two capacity values are defined:

- Filling capacity:

The quantity of oil that the tank is able to hold, allowing for the volume occupied by the pump and the suction assembly kit.

- Suction capacity:

the maximum quantity of the oil the pump is able to draw, hence the quantity of the oil that effectively can be used.

The values given in the table relate to an AP100/1.7 pump with its standard suction assembly kit.

A tolerance of $\pm 5\%$ is allowed on the values indicated.

3.1.2 Square tanks from 1.5 to 3.5 litres

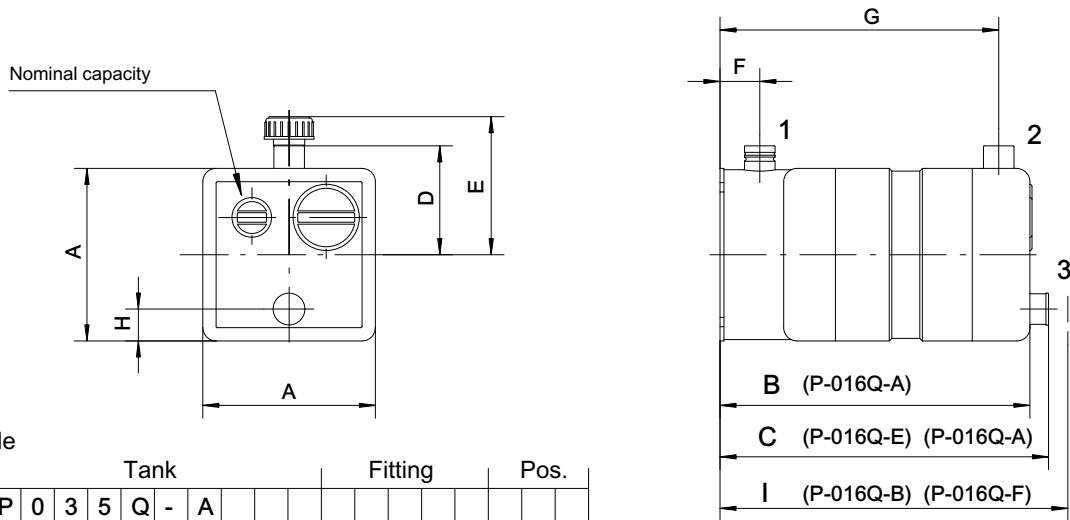

Nom Cap	Type	Code	A		B		C		D		E		F		G		H		I	
			mm	inch	mm	inch	mm	inch	mm	inch	mm	inch	mm	inch	mm	inch	mm	inch	mm	inch
1.5 L	P-015Q-A	200973410020	130	5.2	132	5.2	145	5.7	82	3.3	104	4.1	30	1.2	107	4.3	24	1.0		
1.5 L	P-015Q-B	200973410030	130	5.2	132	5.2	145	5.7	82	3.3	104	4.1	30	1.2	107	4.3	24	1.0		
1.5 L	P-015Q-E	200973410060	130	5.2	132	5.2	145	5.7	82	3.3	104	4.1	30	1.2	107	4.3	24	1.0	150	5.9
1.5 L	P-015Q-F	200973410070	130	5.3	132	5.2	145	5.7	82	3.3	104	4.1	30	1.2	107	4.3	24	1.0	150	5.9
1.6 L	P-016Q-A	200973490010	130	5.3	150	5.9			82	3.3	104	4.1	30	1.2				1.0		
2.5 L	P-025Q-A	200973420020	130	5.3	235	9.3	248	9.8	82	3.3	104	4.1	30	1.2	210	8.3	24	1.0		
2.5 L	P-025Q-B	200973420030	130	5.3	235	9.3	248	9.8	82	3.3	104	4.1	30	1.2	210	8.3	24	1.0		
2.5 L	P-025Q-E	200973420060	130	5.3	235	9.3	248	9.8	82	3.3	104	4.1	30	1.2	210	8.3	24	1.0	253	10.0
2.5 L	P-025Q-F	200973420070	130	5.3	235	9.3	248	9.8	82	3.3	104	4.1	30	1.2	210	8.3	24	1.0	253	10.0
3.5 L	P-035Q-A	200973430020	130	5.3	300	11.8	313	12.3	82	3.3	104	4.1	30	1.2	275	10.8	24	1.0		
3.5 L	P-035Q-B	200973430030	130	5.3	300	11.8	313	12.3	82	3.3	104	4.1	30	1.2	275	10.8	24	1.0		
3.5 L	P-035Q-E	200973430060	130	5.3	300	11.8	313	12.3	82	3.3	104	4.1	30	1.2	275	10.8	24	1.0	318	12.5
3.5 L	P-035Q-F	200973430070	130	5.3	300	11.8	313	12.3	82	3.3	104	4.1	30	1.2	275	10.8	24	1.0	318	12.5

Horizontal mounting

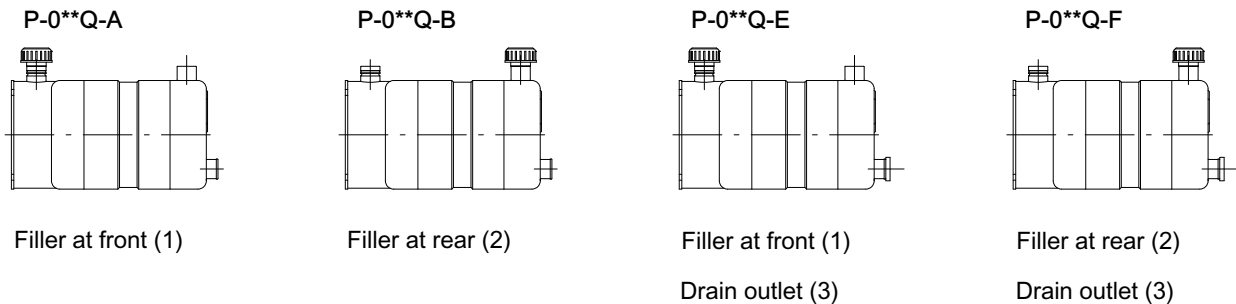

Vertical mounting

P-0**Q-A L30

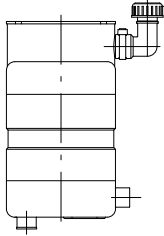

Filler at front (1)
L= 30 fitting (1)

P-0**Q-A L115

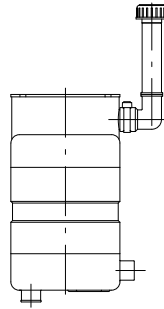

Filler at front (1)
L= 115 fitting (1)

P-0**Q-E L30

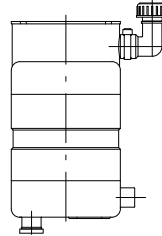

Filler at front (1)
L= 30 fitting (1)
Drain outlet (3)

P-0**Q-E L115

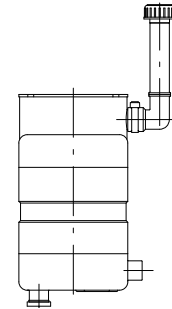

Filler at front (1)
L=115 fitting (1)
Drain outlet (3)

Filler fittings for vertical mounting positions

L= 30 fitting

code 200970000390

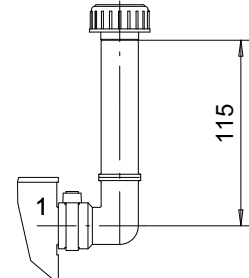
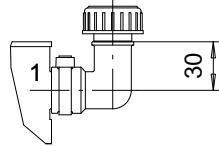

L= 115 fitting code 200970000380

Example

	Tank					Fitting			Pos.
3	P	0	2	5	Q - A	L	3	0	

Filling capacity

AP100/1.7 pump, standard suction assembly kit

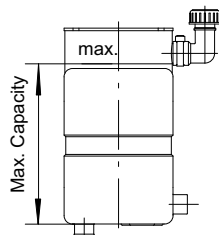
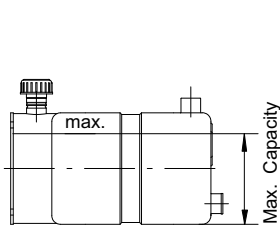

Suction capacity

AP100/1.7 pump, standard suction assembly kit

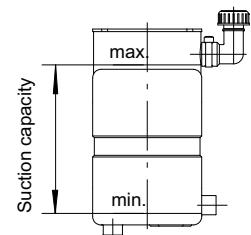
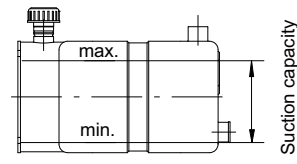

Nominal capacity	Horizontal	Vertical	Type
1.5 l	1.15 l	1.2 l	P-015Q
1.6 l	1.4 l	1.45 l	P-016Q
2.5 l	2.5 l	2.6 l	P-025Q
3.5 l	3.5 l	3.6 l	P-035Q

Nominal capacity	Horizontal	Vertical	Type
1.5 l	0.82 l	0.9 l	P-015Q
1.6 l	1.15 l	1.15 l	P-016Q
2.5 l	2.3 l	2.35 l	P-025Q
3.5 l	3.2 l	3.25 l	P-035Q

Notes of fitment:

Care needs to be taken over the following aspects of fitting and securing the tank. For horizontal mounting arrangements, the clip fastener must be positioned within the limits indicated in picture A. Other positions can result in deformation of the tank, and consequently in the risk of leakage.

The clip should not be positioned against the filler as

shown in pack housing, compressing the spigot O-Ring (fig.C).

Fig. D shows the range of angular adjustment allowed to the filler. Once positioned, the filler is tightened with a relative clip as shown in picture E, which also indicates the groove provides the sealing action when the filler is in use.

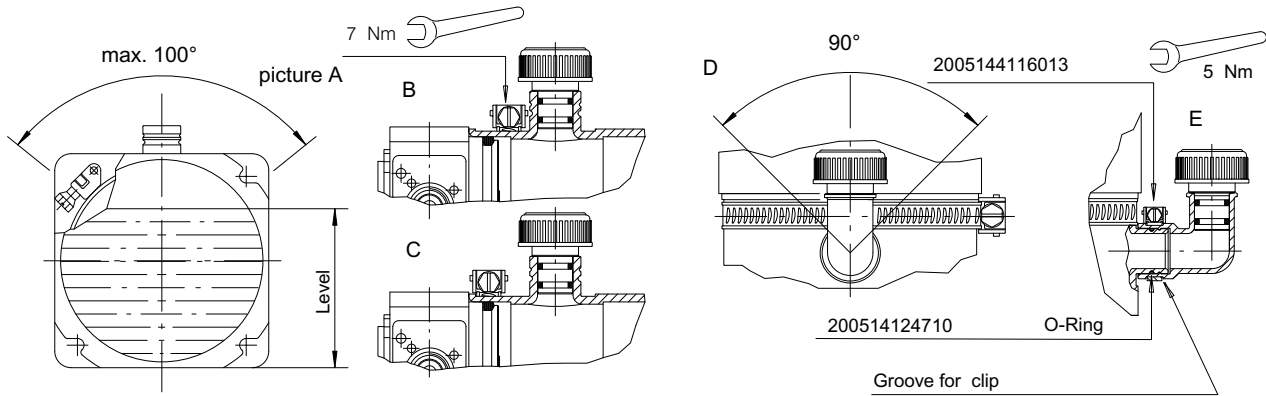

Fixing kit for plastic tank up to 2.5 litres

code: 200771900150

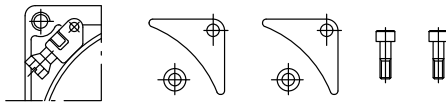

- 200544116021 Tank fixing clip
- 200677400400 Tank fixing bracket (q.ty 2)
- 200671100101 Bracket spacer (q.ty 2)
- 200521203007 M6X18 fixing bolt (q.ty 2)

Fixing kit for plastic tanks of 3.5 litres

code: 200771900160

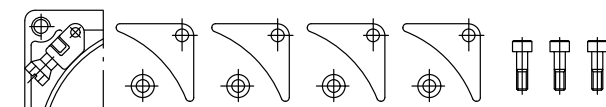

- 200544116021 Tank fixing clip
- 200677400400 Tank fixing bracket (q.ty 4)
- 200671100101 Bracket spacer (q.ty 4)
- 200521203007 M6X18 fixing bolt (q.ty 4)

Oil drain plug

code: 200778000120



- 200678000670 Plug Ø18
- 200514137710 O-Ring 3050

Filler cap

code: 200527099901

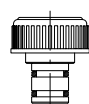

- Ø18 filler cap with double breather and O-Ring (q.ty 2)

3.1.3 Square tanks from 6 up to 12 litres

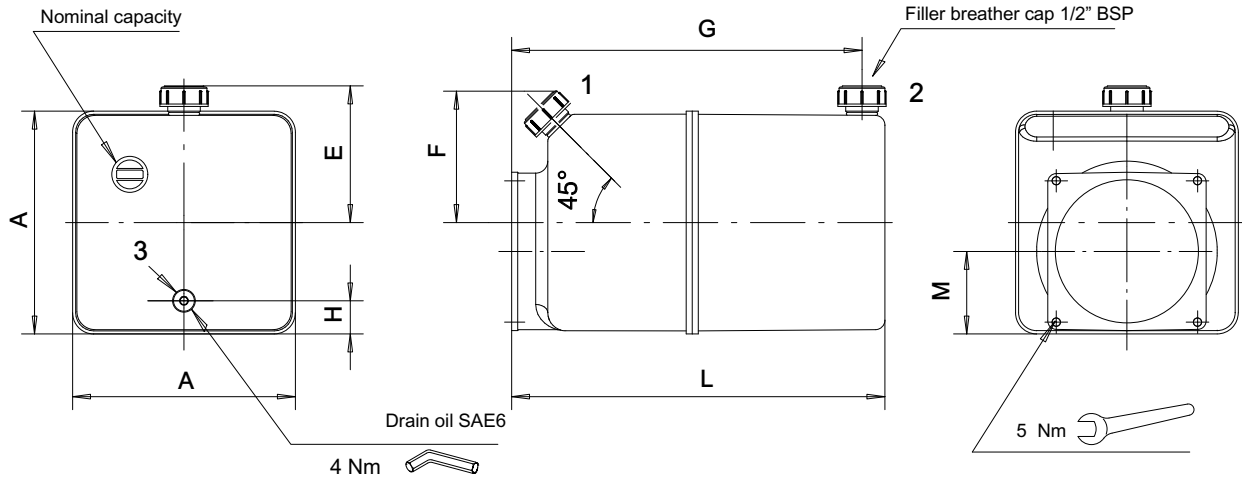

Example

	Tank				Fitting				Pos.							
3	P	0	8	0	Q	-	A	B	T							

Tanks color standard is neutral translucent

Nom. Cap.	Type	Code	A		L		E		F		G		H		M	
			mm	inch	mm	inch	mm	inch	mm	inch	mm	inch	mm	inch	mm	inch
6 l	P-060Q-A BT	200973490140	180	7.1	310	12.2			110	4.4	291	11.5	25	1.0	66	2.6
8 l	P-080Q-A BT	200973450050	180	7.1	365	14.4			110	4.4	346	13.7	25	1.0	66	2.6
10 l	P-100Q-A BT	200973460050	180	7.1	420	16.6			110	4.4	401	15.8	25	1.0	66	2.6
12 l	P-120Q-A BT	200973490150	180	7.1	490	19.3			110	4.4	471	18.6	25	1.0	66	2.6
6 l	P-060Q-B BT	200973490120	180	7.1	310	12.2	110	4.4			291	11.5	25	1.0	66	2.6
8 l	P-080Q-B BT	200973450040	180	7.1	365	14.4	110	4.4			346	13.7	25	1.0	66	2.6
10 l	P-100Q-B BT	200973460040	180	7.1	420	16.6	110	4.4			401	15.8	25	1.0	66	2.6
12 l	P-120Q-B BT	200973490130	180	7.1	490	19.3	110	4.4			471	18.6	25	1.0	66	2.6
6 l	P-060Q-E BT	200973490100	180	7.1	310	12.2			110	4.4	291	11.5	25	1.0	66	2.6
8 l	P-080Q-E BT	200973450030	180	7.1	365	14.4			110	4.4	346	13.7	25	1.0	66	2.6
10 l	P-100Q-E BT	200973460030	180	7.1	420	16.6			110	4.4	401	15.8	25	1.0	66	2.6
12 l	P-120Q-E BT	200973490110	180	7.1	490	19.3			110	4.4	471	18.6	25	1.0	66	2.6
6 l	P-060Q-F BT	200973490060	180	7.1	310	12.2	110	4.4			291	11.5	25	1.0	66	2.6
8 l	P-080Q-F BT	200973450010	180	7.1	365	14.4	110	4.4			346	13.7	25	1.0	66	2.6
10 l	P-100Q-F BT	200973460010	180	7.1	420	16.6	110	4.4			401	15.8	25	1.0	66	2.6
12 l	P-120Q-F BT	200973490070	180	7.1	490	19.3	110	4.4			471	18.6	25	1.0	66	2.6

Horizontal/vertical mounting

P-0**Q-A BT*

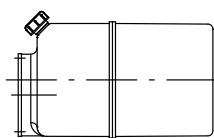

Filler at front (1)

P-0**Q-B BT

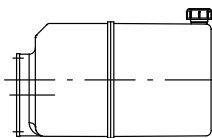

Filler at rear (2)

P-0**Q-E BT*

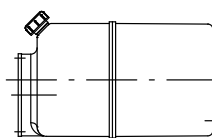

Filler at front (1)

Drain outlet (3)

P-0**Q-F BT

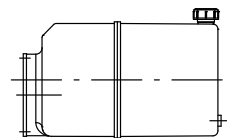

Filler at rear (2)

Drain outlet (3)

* (horizontal and vertical mounting)

Filling capacity

AP100/5 pump, standard suction assembly kit

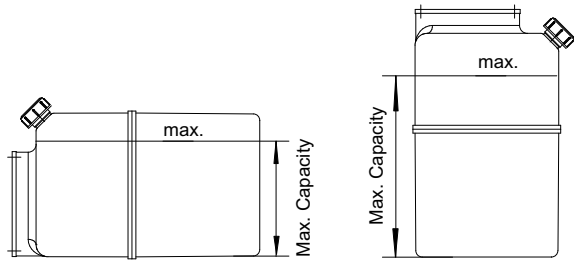

Nominal capacity	Horizontal	Vertical	Type
6 l	6.5 l	6.5 l	P-060Q-**
8 l	8.5 l	8.5 l	P-080Q-**
10 l	10.5 l	10.5 l	P-100Q-**
12 l	12.5 l	12.5 l	P-120Q-**

Suction capacity

AP100/5 pump, standard suction assembly kit

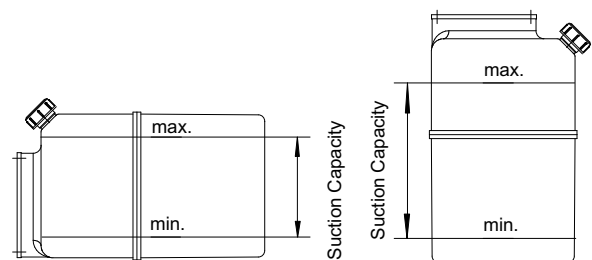

Nominal capacity	Horizontal	Vertical	Type
6 l	5.5 l	5.5 l	P-060Q-**
8 l	7.5 l	7.5 l	P-080Q-**
10 l	9.5 l	9.5 l	P-100Q-**
12 l	11.5 l	11.5 l	P-120Q-**

Notes of fitment

To assemble the horizontal tanks see the notes at page 43.

To assemble the vertical tanks do not use the tank fixing clip code 200544116021

Fixing kit for vertical tanks code: 200771900280

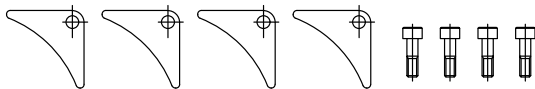

- 200677400400 Tank fixing bracket (q.ty 4)
- 200521203007 M6X18 fixing bolt (q.ty 4)

Fixing kit for horizontal tanks code: 200771900310

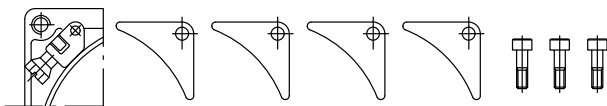

- 200544116021 Tank fixing clip
- 200677400400 Tank fixing bracket (q.ty 4)
- 200521203007 M6X18 fixing bolt (q.ty 4)

Oil drain plug code: 200527481501



TCEI 9/16UNF SAE6 plug

Filler cap code: 200527060502

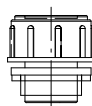

1/2" BSP Plug

3.1.4 Rectangular tanks of 5 litres

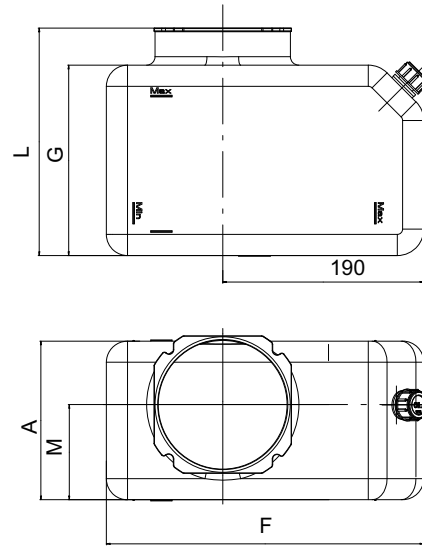
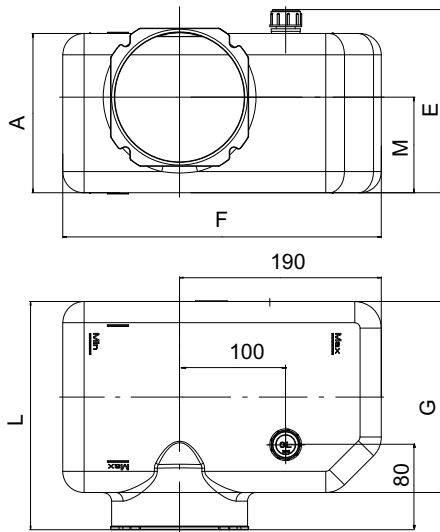

Example

	Tank	Fitting	Pos.
3	P 0 5 0 S - L B T		

Example

	Tank	Fitting	Pos.
3	P 0 5 0 S - A B T		

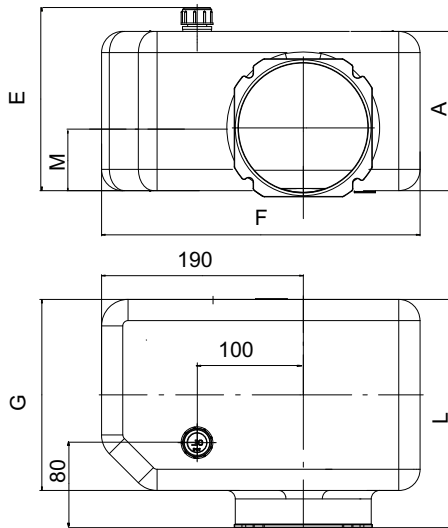

Example

	Tank	Fitting	Pos.
3	P 0 5 0 S - I B T		

Horizontal/Vertical mounting

P-050S-L BT

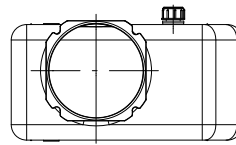

P-050S-I BT

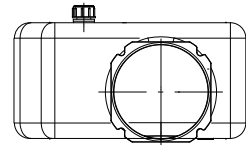

P-050S-A BT

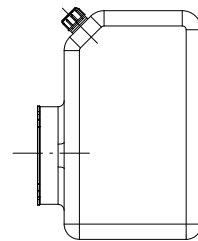

P-050S-A BT

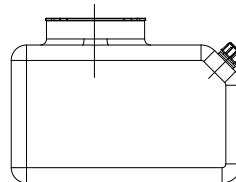

Nom. Cap.	Type	Code	A		L		E		F		G		M	
			mm	inch.	mm	inch.	mm	inch.	mm	inch.	mm	inch.	mm	inch.
5 l	P-050S-L BT	200973440010	150	6.03	215	8.64	172.5	6.93	300	12.06	180	7.23	90	3.62
5 l	P-050S-A BT	200973440020	150	6.03	215	8.64			300	12.06	180	7.23	90	3.62
5 l	P-050S-I BT	200773440030	150	6.03	215	8.64	172.5	6.93	300	12.06	180	7.23	60	2.41

Filling capacity

UP100/5 pump, standard suction assembly kit

P-050S-LBT / P-050S-IBT

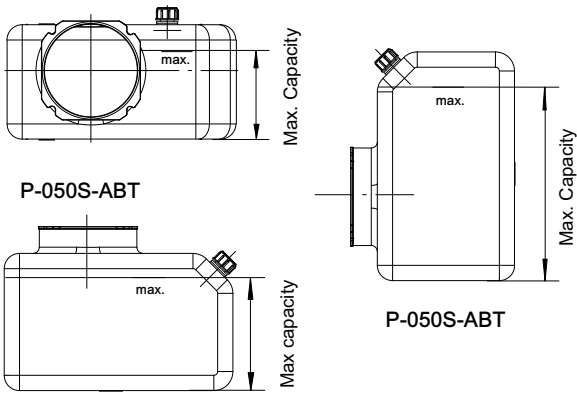

P-050S-ABT

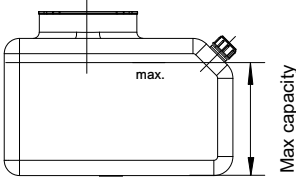

P-050S-ABT

Nominal capacity	Horizontal	Vertical	Type
5 l	6.2 l	6.0 l	P-050S-ABT
5 l	6.1 l	/	P-050S-LBT
5 l	6.1 l	/	P-050S-IBT

Suction capacity

AP100/5 pump, standard suction assembly kit

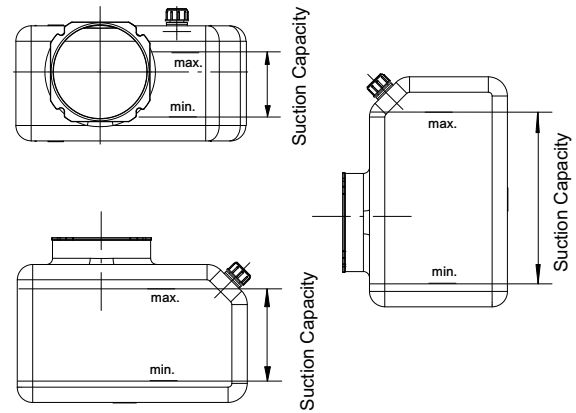

Nominal capacity	Horizontal	Vertical	Type
5 l	5.5 l	5.0 l	P-050S-ABT
5 l	5.3 l	/	P-050S-LBT
5 l	5.3 l	/	P-050S-IBT

Notes of fitment

Fixing kit

code: 200771900160

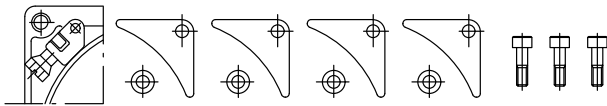

- 200544116021 Tank fixing clip
- 200677400400 Tank fixing bracket (q.ty 4)
- 200671100101 Bracket spacer (q.ty 4)
- 200521203007 M6X18 fixing bolt (q.ty 4)

Filler cap

code: 200527060502

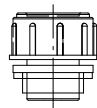

1/2" BSP Plug

3.1.5 Round tanks from 6 to 14 litres

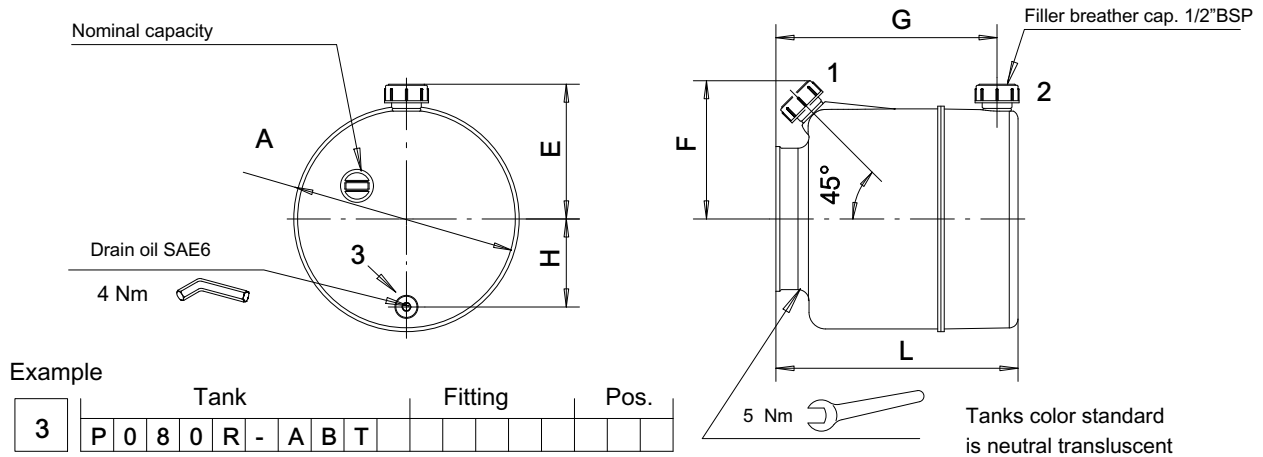

Nom. Cap.	Type	Code	A		L		E		F		G		H	
			mm	inch.	mm	inch.	mm	inch.	mm	inch.	mm	inch.	mm	inch.
6 l	P-060R-A BT	200973490230	200	7.1	220	8.7			127	5	201	8.0	80	3.2
8 l	P-080R-A BT	200973450070	200	7.1	285	11.3			127	5	266	10.5	80	3.2
10 l	P-100R-A BT	200973460070	200	7.1	325	12.8			127	5	306	12.1	80	3.2
12 l	P-120R-A BT	200973490240	200	7.1	410	16.2			127	5	391	15.4	80	3.2
14 l	P-140R-A BT	200973490200	200	7.1	490	19.3			127	5	471	18.6	80	3.2
6 l	P-060R-B BT	200973490210	200	7.1	220	8.7	123	4.9			201	8.0	80	3.2
8 l	P-080R-B BT	200973450060	200	7.1	285	11.3	123	4.9			266	10.5	80	3.2
10 l	P-100R-B BT	200973460060	200	7.1	325	12.8	123	4.9			306	12.1	80	3.2
12 l	P-120R-B BT	200973490220	200	7.1	410	16.2	123	4.9			391	15.4	80	3.2
14 l	P-140R-B BT	200973490190	200	7.1	490	19.3	123	4.9			471	18.6	80	3.2
6 l	P-060R-E BT	200973490290	200	7.1	220	8.7			127	5	201	8.0	80	3.2
8 l	P-080R-E BT	200973450100	200	7.1	285	11.3			127	5	266	10.5	80	3.2
10 l	P-100R-E BT	200973460100	200	7.1	325	12.8			127	5	306	12.1	80	3.2
12 l	P-120R-E BT	200973490300	200	7.1	410	16.2			127	5	391	15.4	80	3.2
14 l	P-140R-E BT	200973490180	200	7.1	490	19.3			127	5	471	18.6	80	3.2
6 l	P-060R-F BT	200973490250	200	7.1	220	8.7	123	4.9			201	8.0	80	3.2
8 l	P-080R-F BT	200973450080	200	7.1	285	11.3	123	4.9			266	10.5	80	3.2
10 l	P-100R-F BT	200973460080	200	7.1	325	12.8	123	4.9			306	12.1	80	3.2
12 l	P-120R-F BT	200973490260	200	7.1	410	16.2	123	4.9			391	15.4	80	3.2
14 l	P-140R-F BT	200973490160	200	7.1	490	19.3	123	4.9			471	18.6	80	3.2

Horizontal/vertical mounting

P-0**R-A BT *

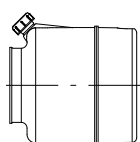

Filler at front (1)

P-0**R-B BT

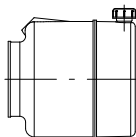

Filler at rear (2)

P-0**R-E BT *

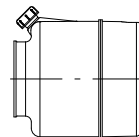

Filler at front (1)

Drain outlet (3)

P-0**R-F BT

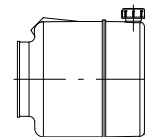

Filler at rear (2)

Drain outlet (3)

* (horizontal and vertical mounting)

Filling capacity

AP100/5 pump, standard suction assembly kit

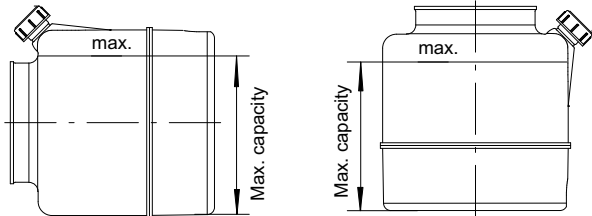

Nominal capacity	Horizontal	Vertical	Type
6 l	4.8 l	4.5 l	P-060R-**
8 l	6.8 l	6.5 l	P-080R-**
10 l	7.5 l	8.0 l	P-100R-**
12 l	8.5 l	8.5 l	P-120R-**
14 l	12 l	12.5 l	P-140R-**

Suction capacity

AP100/5 pump, standard suction assembly kit

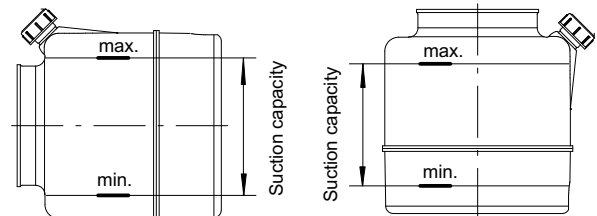

Nominal capacity	Horizontal	Vertical	Type
6 l	4.5 l	3.5 l	P-060R-**
8 l	6.5 l	5.0 l	P-080R-**
10 l	7.0 l	7.0 l	P-100R-**
12 l	8.0 l	7.5 l	P-120R-**
14 l	11.5 l	11.5 l	P-140R-**

Notes of fitment

To assemble the horizontal tanks see the notes at page 43.

To assemble the vertical tanks do not use the tank fixing clip code 200544116021

Fixing kit for vertical tanks code: 200771900280

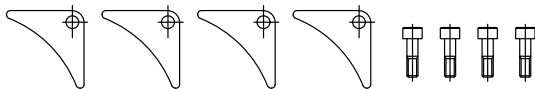

- 200677400400 Tank fixing bracket (q.ty 4)
- 200521203007 M6X18 fixing bolt (q.ty 4)

Fixing kit for horizontal tanks code : 200771900310

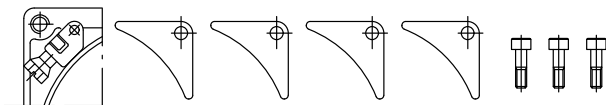

- 200544116021 Tank fixing clip
- 200677400400 Tank fixing bracket (q.ty 4)
- 200521203007 M6X18 fixing bolt (q.ty 4)

Oil drain plug code: 200527481501



TCEI 9/16UNF SAE6 plug

Filler cap code: 200527060502

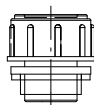

1/2" BSP plug

3.1.6 Plastic tanks horizontal assembling positions

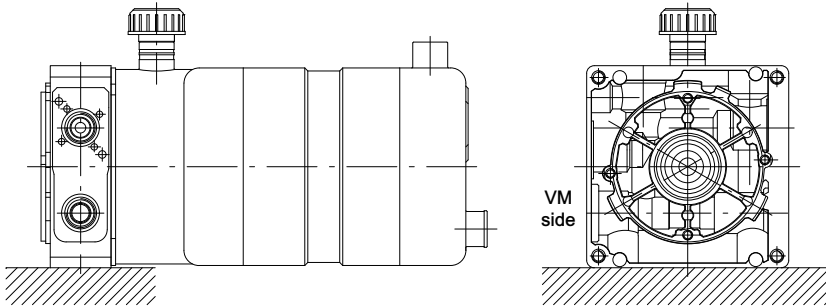

Assembling position
P01

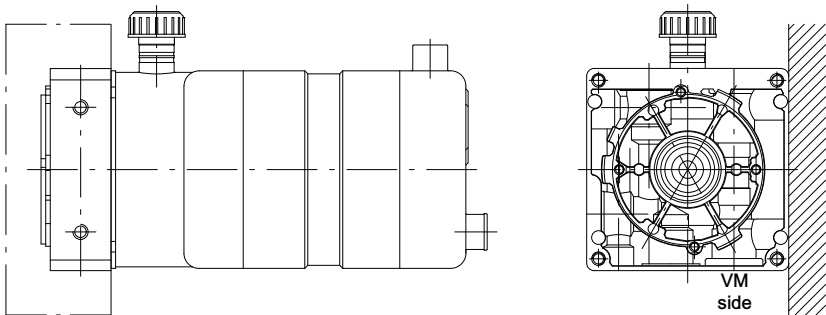

Assembling position
P03

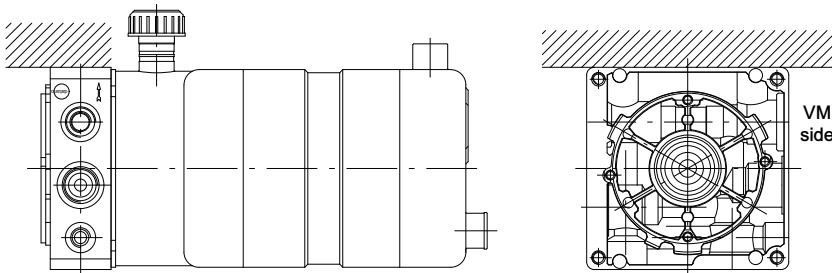

Assembling position
P02

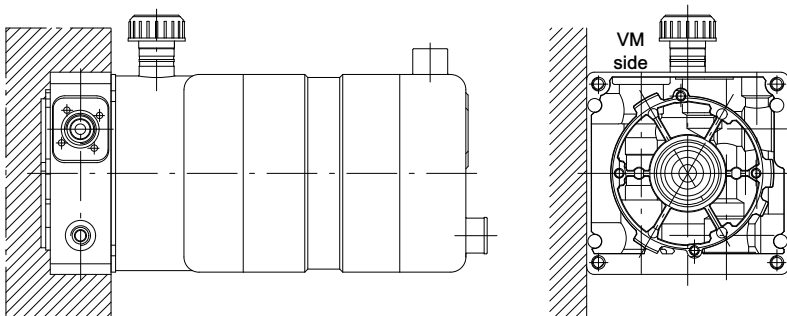

Assembling position
P04

Example

	Tank						Fitting				Pos.			
3	P	0	2	5	Q	-	A					P	0	1

3.1.7 Plastic tanks vertical assembling positions

Assembling position P15

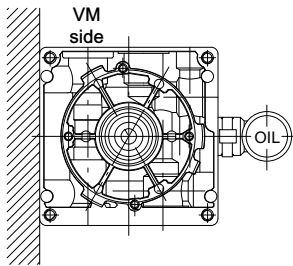
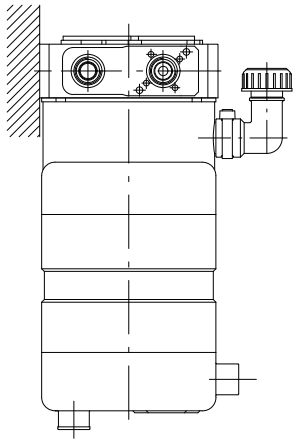

Assembling position P35

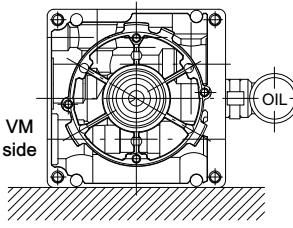
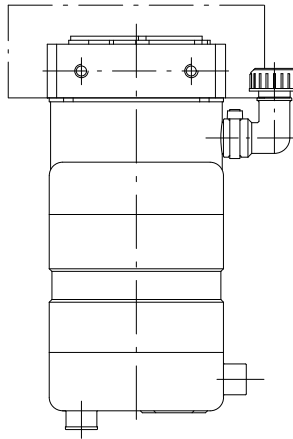

Assembling position P25

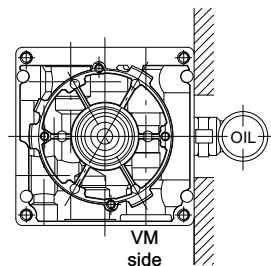
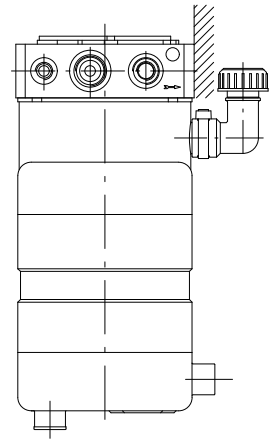

Assembling position P45

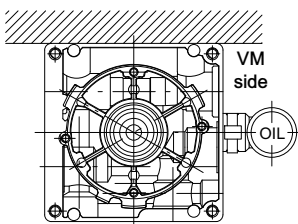
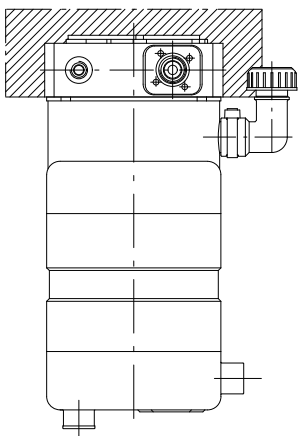

Example

	Tank						Fitting			Pos.			
3	P	0	3	5	Q	-	A	L	3	0	P	1	5

The power pack housing shown in the examples is UP100/K1

3.2 Metal tanks up to 18 litres

3.2.1 Technical information

Materials: Sheet metal.

Color: Black paint finish (Standard)

Condition of use: Suitable fluids: mineral oil based hydraulic fluids responding to ISO -DIN standards.

Operating temperature range: -15 / +80°C

Hydrocarbon based fluids (e.g. benzene, benzol, etc.) must not be used.

Versions: tanks are available in numerous versions, allowing installation of the power pack in different horizontal and vertical positions.

3.2.2 Tanks L050R-01, L080R-01

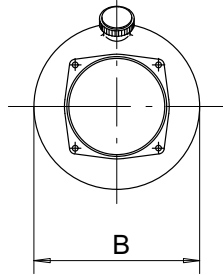
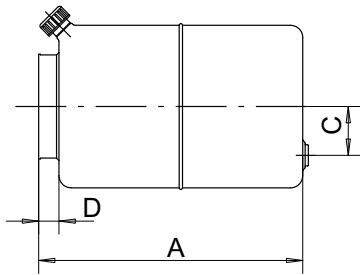

Example

	Tank						Fitting			Pos.			
3	L	0	8	0	R	-	0	1			P	1	5

Nom. Cap.	Type	Code	A		B		C		D		Oil filler cap	Oil drain plug
			mm	inch.	mm	inch.	mm	inch.	mm	inch.		
5 l	L050R-01	200972440320	270	10.7	170	6.7	50	2	25	1.0	3/8" BSP	1/2" BSP
8 l	L080R-01	200972450060	285	11.3	200	7.9	60	2.4	25	1.0	3/8" BSP	1/2" BSP

Horizontal assembling positions

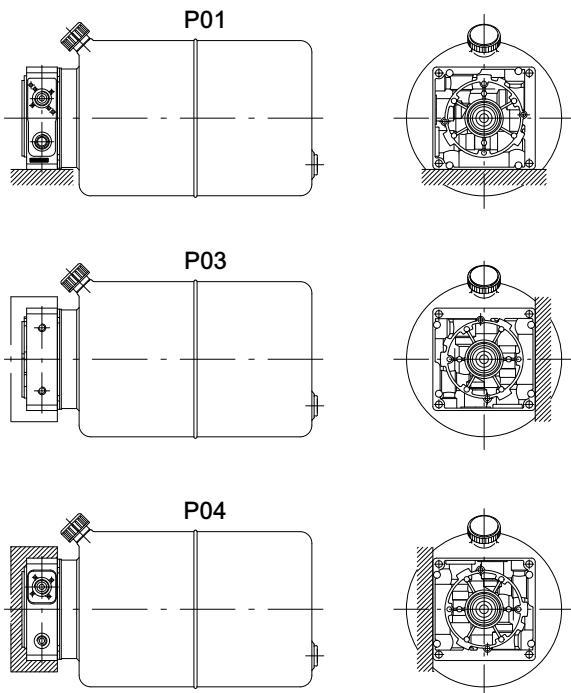

Vertical assembling positions

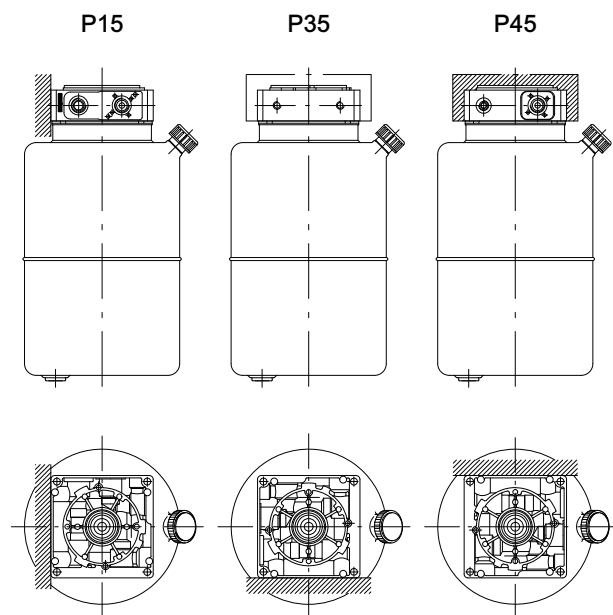

3.2.3 Tanks L050R-02, L080R-02

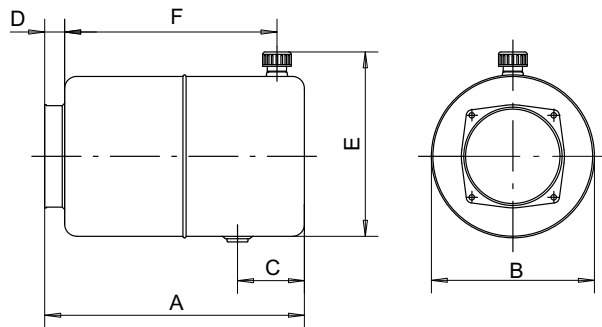

Example

	Tank						Fitting		Pos.			
3	L	0	8	0	R	-	0	2		P	0	1

Nom. Cap.	Type	Code	A		B		C		D		E		F		Oil filler cup	Oil drain plug
			mm	inch	mm	inch	mm	inch	mm	inch	mm	inch	mm	inch		
5 l	L050R-02	200972440010	270	10.7	170	6.7	50	2	25	1.0	195	7.7	212.5	8.4	3/8" BSP	1/2" BSP
8 l	L080R-02	200972450010	285	11.3	200	7.9	60	2.4	25	1.0	228	9.0	225	8.9	3/8" BSP	1/2" BSP

Horizontal assembling positions

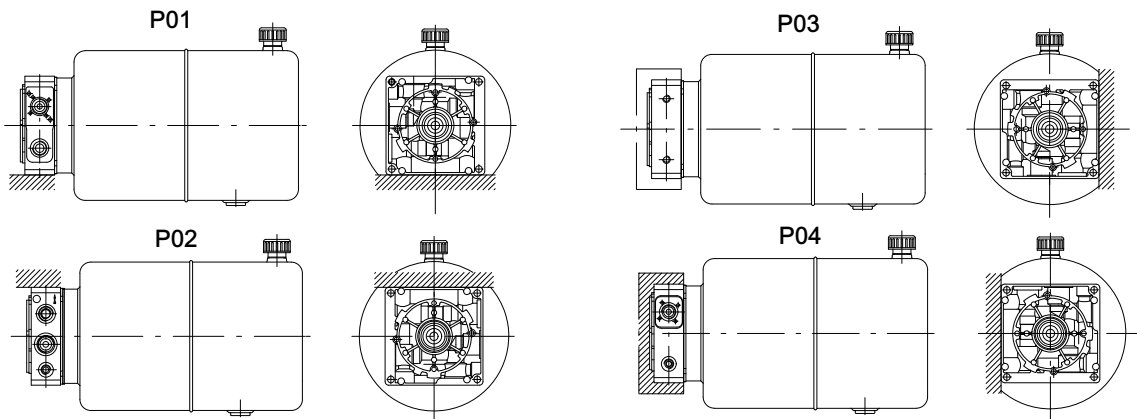

Filling capacity

AP100/5 pump, standard suction assembly kit

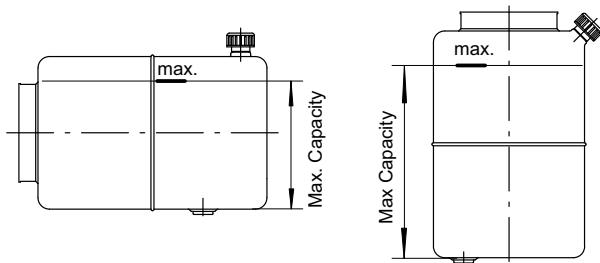

Nominal capacity	Horizontal	Vertical	Type
5 l	4.9 l	4.7 l	L050R-01
5 l	4.9 l	—	L050R-02
8 l	7.5 l	7.0 l	L080R-01
8 l	7.5 l	—	L080R-02

Suction capacity

AP100/5 pump, standard suction assembly kit

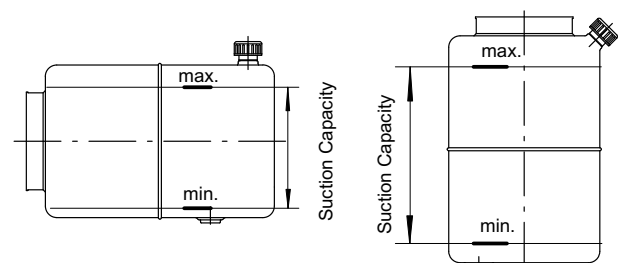

Nominal capacity	Horizontal	Vertical	Type
5 l	4.4 l	4.4 l	L050R-01
5 l	4.5 l	—	L050R-02
8 l	7.0 l	6.0 l	L080R-01
8 l	7.0 l	—	L080R-02

3.2.4 Tank L070Q-03

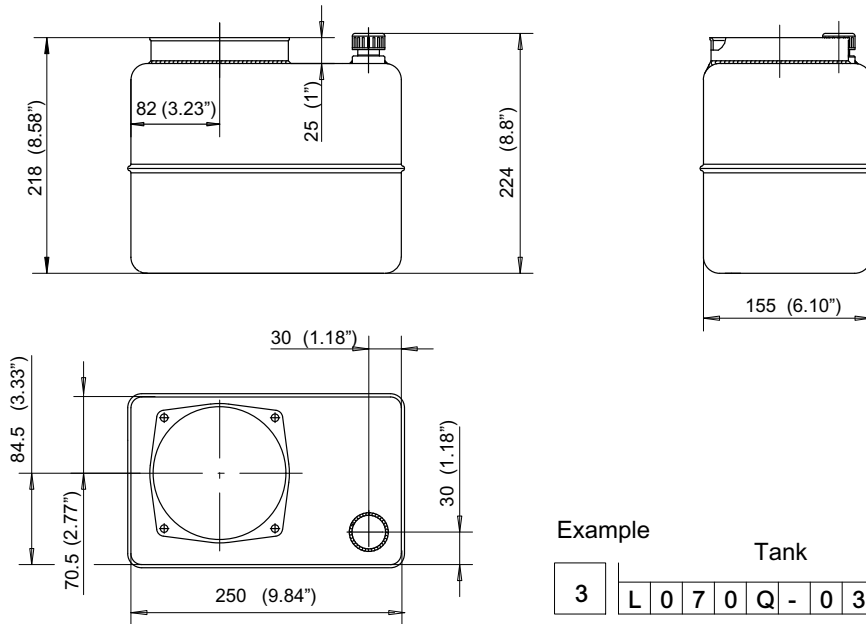

Nominal capacity	Type	Code	Oil filler cap	Oil drain plug
7 l	L070Q-03	200972490650	1/2" BSP	

Vertical assembling positions

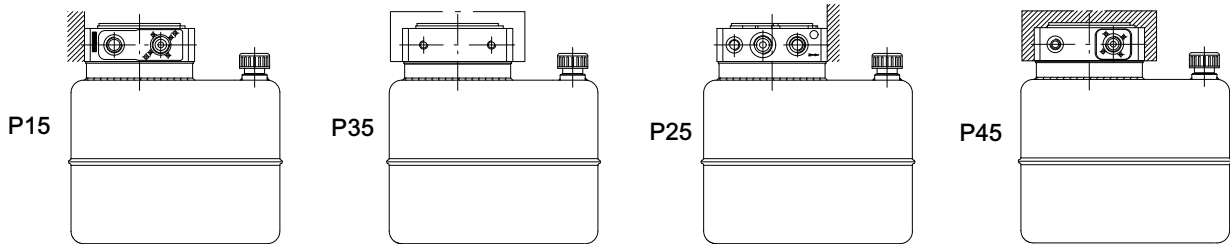

Filling capacity

AP100/5 pump, standard suction assembly kit

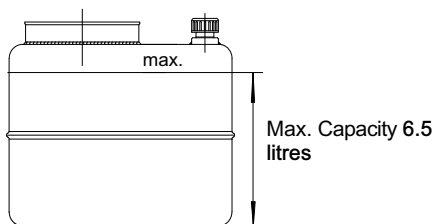

Suction capacity

AP100/5 pump, standard suction assembly kit

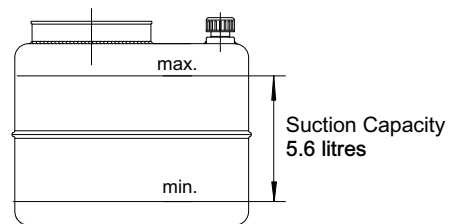

3.2.5 Tank L100R-01

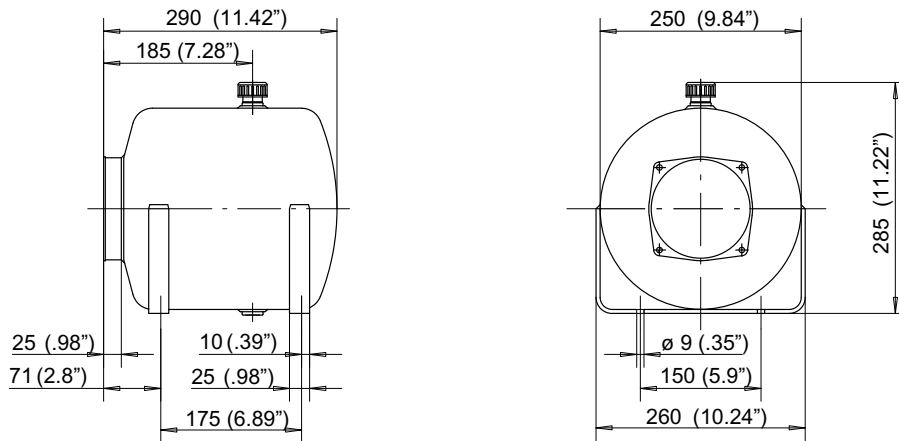

Example

	Tank				Fitting				Pos.				
3	L	1	0	0	R	-	0	1			P	0	1

Nominal Capacity	Type	Code	Oil filler cap	Oil drain plug
10 litres	L100R-01	200972460020	1" BSP	3/4" BSP

Horizontal assembling positions

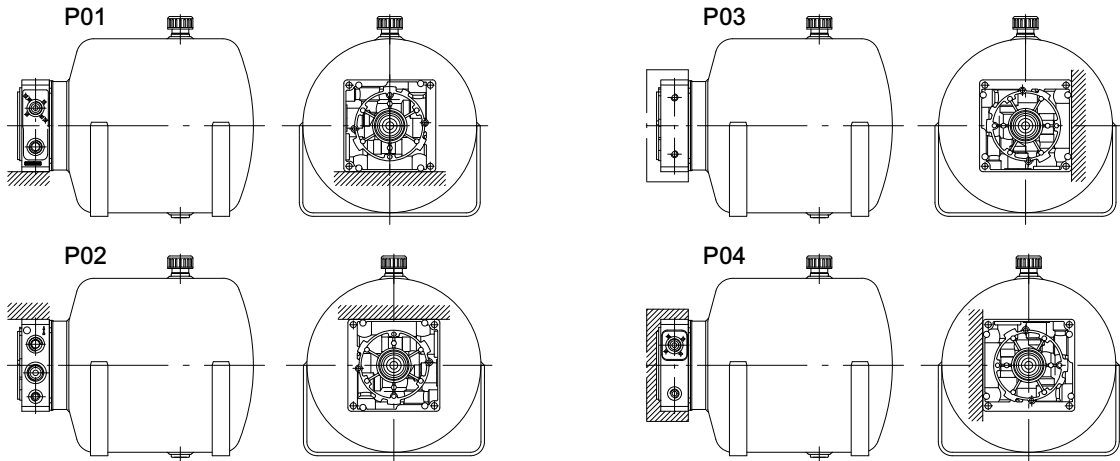

Filling capacity

AP100/5 pump, standard suction assembly kit

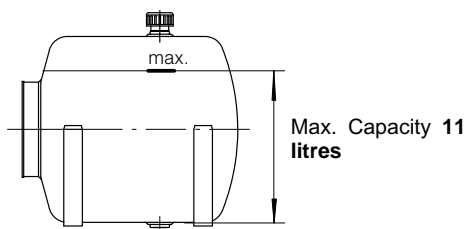

Suction capacity

AP100/5 pump, standard suction assembly kit

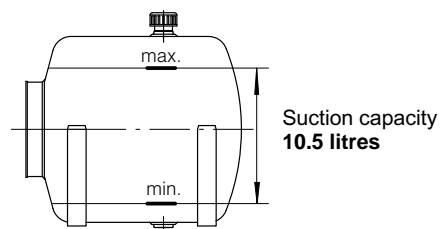

3.2.6 Tank L120Q-01

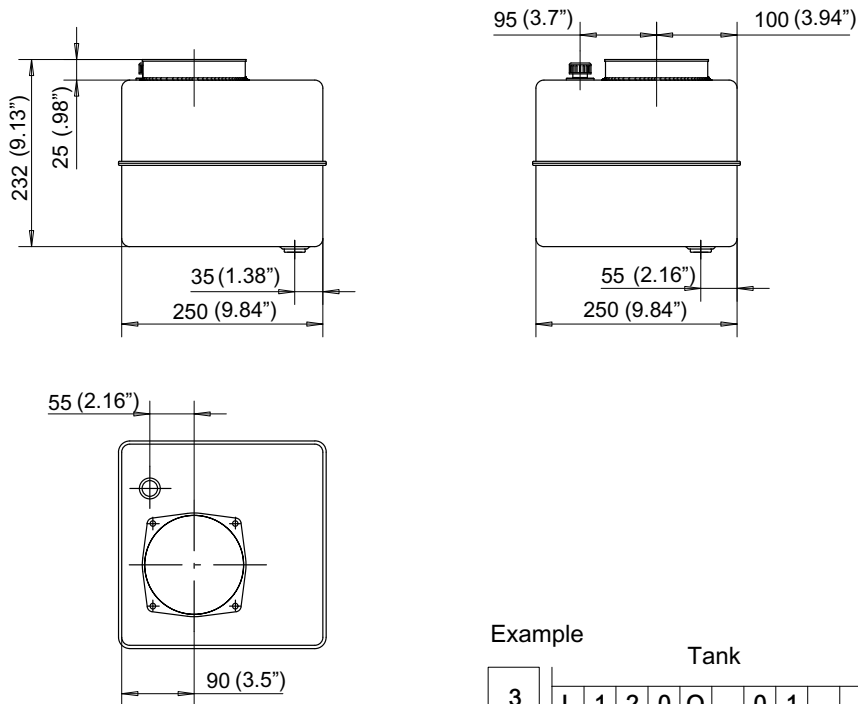

Example

	Tank						Fitting			Pos.				
3	L	1	2	0	Q	-	0	1				P	1	5

Nominal capacity	Type	Code	Oil filler cap	Oil drain plug
12 litres	L120Q-01	200972490150	3/8" BSP	3/8" BSP

Vertical assembling position

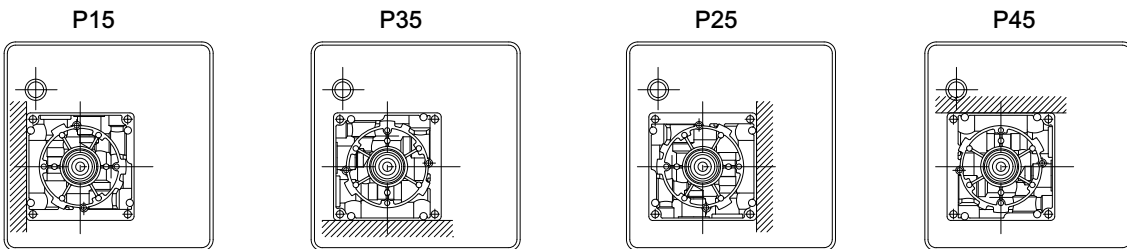

Filling capacity

AP100/5 pump, standard suction assembly kit

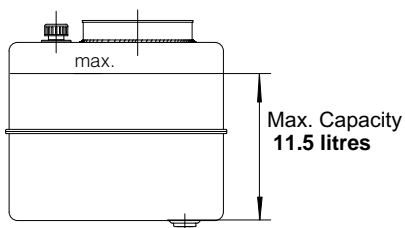

Suction capacity

AP100/5 pump, standard suction assembly kit

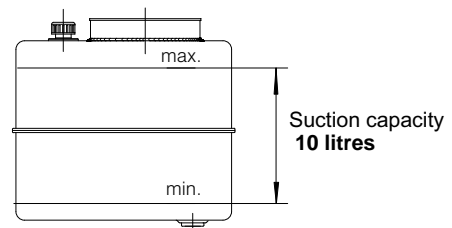

3.2.7 Tank L150Q-01

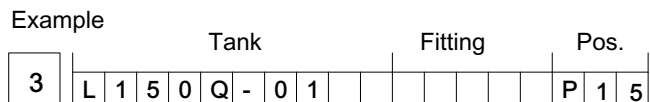
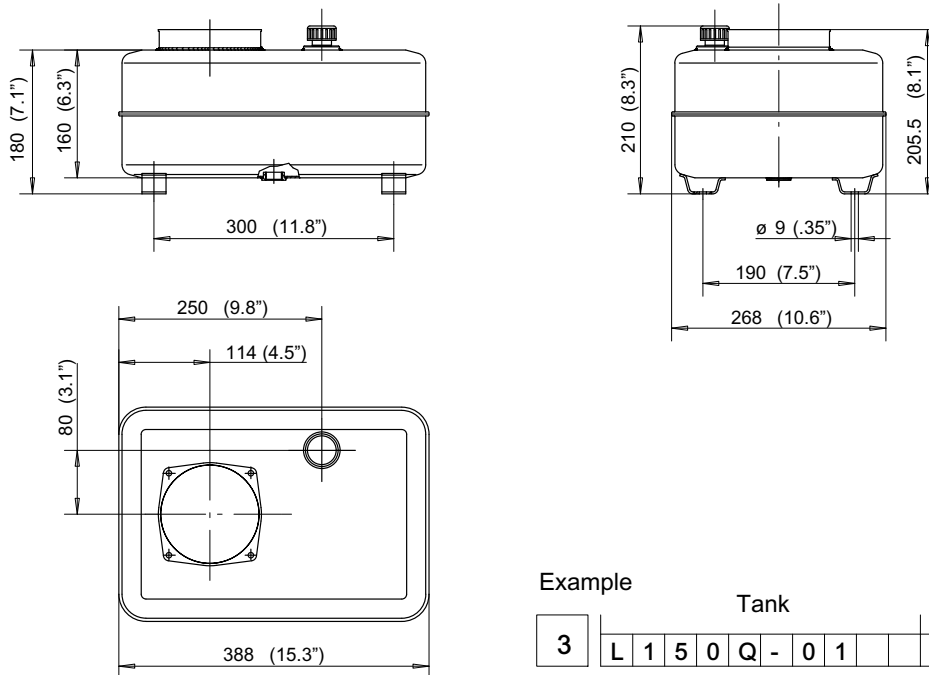

Nominal Capacity	Type	Code	Oil filler cap	Oil drain plug
15 litres	L150Q-01	200972470010	1" BSP	1/2" BSP

Vertical assembling position

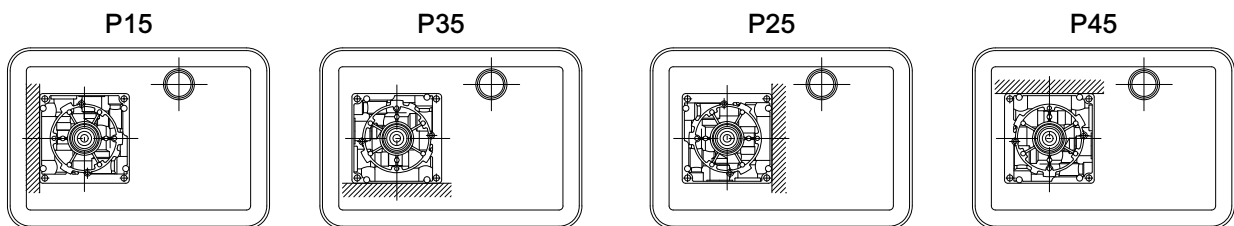

Filling capacity

AP100/5 pump, standard suction assembly kit

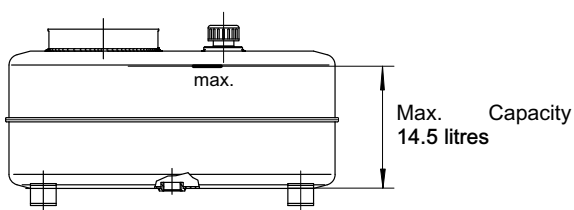

Suction capacity

AP100/5 pump, standard suction assembly kit

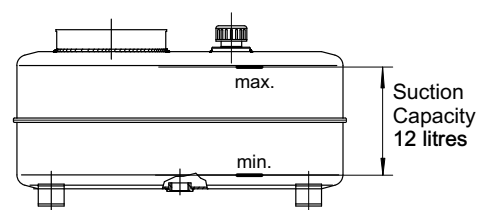

3.2.8 Tank L180R-01

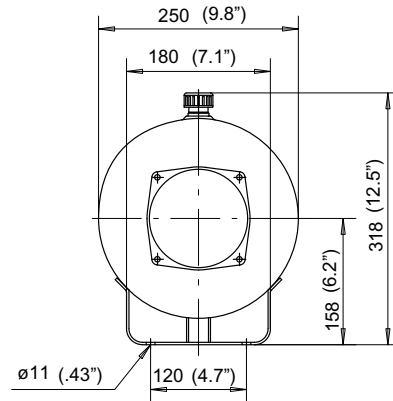
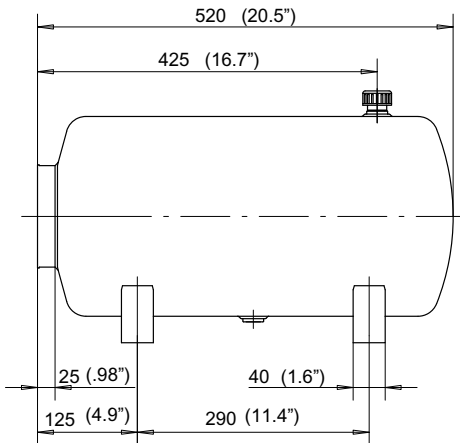

Example

	Tank	Fitting	Pos.
3	L 1 8 0 R - 0 1		P 0 1

Nominal capacity	Type	Code	Oil filler cap	Oil drain plug
18 litres	L180R-01	200972480020	1" BSP	3/4" BSP

Horizontal assembling positions

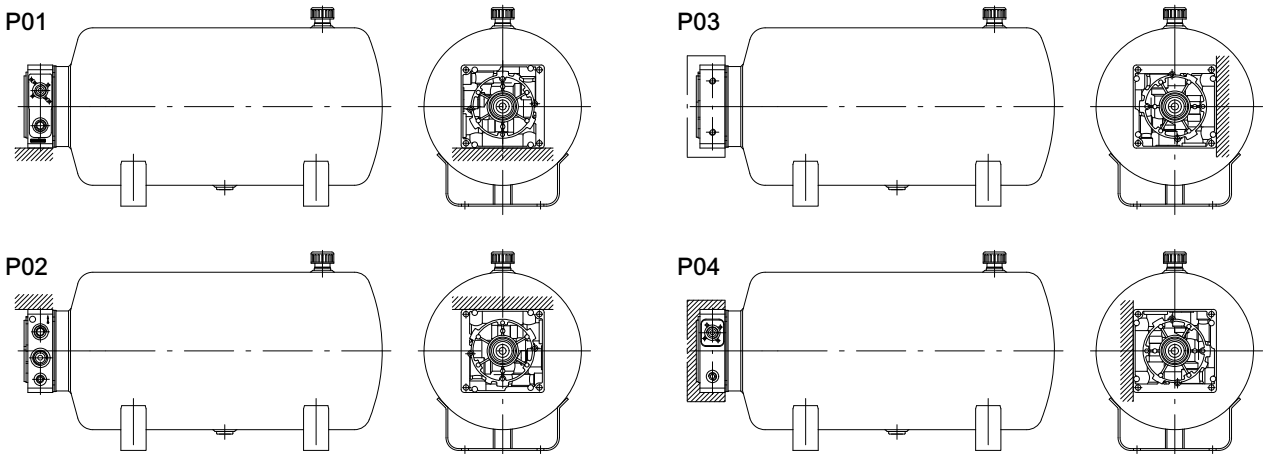

Filling capacity

AP100/5 pump, standard suction assembly kit

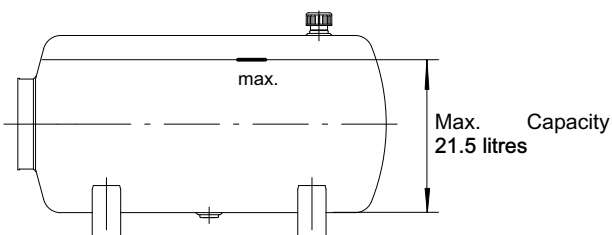

Suction capacity

AP100/5 pump, standard suction assembly kit

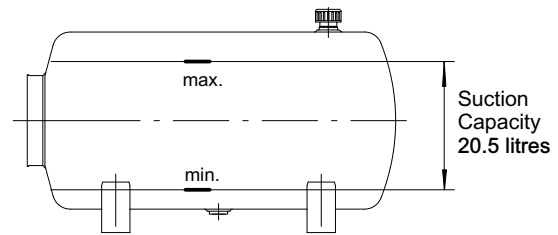

3.2.9 Metal tanks fitting notes

Fixing kit for metal tanks of 3,5 liters and over
code: 200771900180

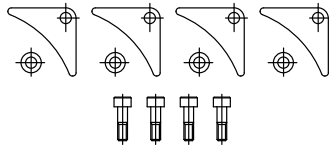

- 200677400400 Fixing bracket (q.ty 4)
- 200671100101 bracket spacer (q.ty 4)
- 200521203007 M6X18 fixing bolt (q.ty 4)

Tank collar
code: 200609400051

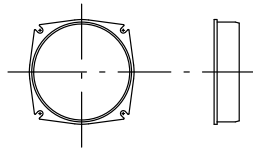

Spigot diameter 123
Height of collar 25 mm.
Material: pressed steel
Provides interface between power pack housing and special tank

Oil filler cap
Plastic material
Complete with breather

Thread:	Code:
3/8" BSP	200678000350
1/2" BSP	200527060502
1" BSP	200527060901

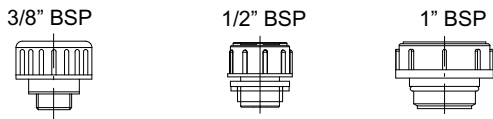

Oil filler cap
Plastic material
Complete with breather
Complete with dipstick

Thread:	Code:
3/8" BSP (L=25)	200678000700
3/8" BSP (L=81)	200678000370
3/8" BSP (L=103)	200678000380
3/8" BSP (L=165)	200678000340
1/2" BSP (L=140)	200678000050
1" BSP (L=165)	200678000500

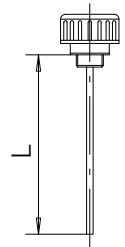

Horizontal assembling for power pack with plastic/metal tank

Important: Overhanging assembling configurations for motor or tank are not admitted

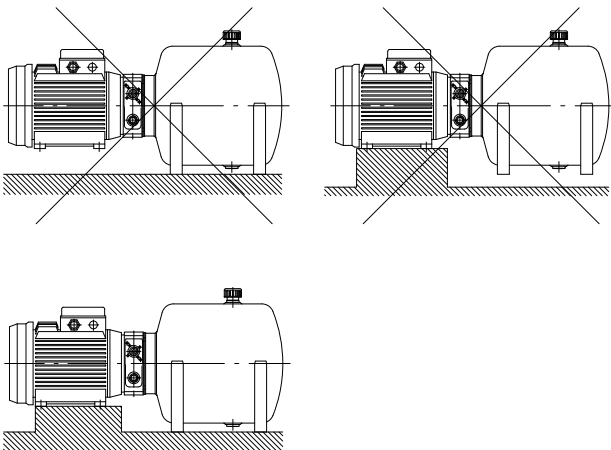

Vertical assembling for power pack with plastic/metal tanks

Important: For hydraulic units assembling A.C. electric motors equal or higher than 1.5 HP- 1.1KW, it's recommended to order the B34 frame size version.

Consequently it is recommended to fix the hydraulic unit by the A.C. electric motor feet or where possible both electric motor and tank feet.

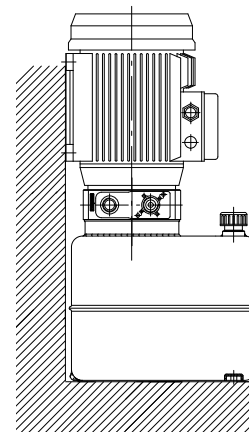

4 Suction/Return assembly kits

This section is intended to assist those customers who choose to purchase single sub-assemblies separately and put together their own power packs.

Table below shows the ordering code for suction and discharging kit.

The right choice is a function of tank capacity, assembly position and pump.

This information is not requested when building a complete power pack ordering code.

4.1 Suction assembly kits for plastic tanks

4.1.1 Suction assembly kits for square tanks from 1,5 to 3,5 litres

Pump S309	Horizontal positions - P01, P02, P03, P04			
	P-015Q-*	P-016Q-*	P-025Q-*	P-035Q-*
AP100/1.2	200685001370	200759902120	200759902120	200759902120
AP100/1.7	200685001370	200759902120	200759902120	200759902120
AP100/2.5	200685001370	200759902120	200759902120	200759902120
AP100/3.5		200759902120	200759902120	200759902120
AP100/4.3		200759902120	200759902120	200759902120
AP100/5			200759902120	200759902120
AP100/6.5			200759902120	200759902120
AP100/8			200759902120	200759902120
AP100/10			200759902120	200759902120

Pump S309	Vertical positions - P15, P35, P25, P45			
	P-015Q-*	P-016Q-*	P-025Q-*	P-035Q-*
AP100/1.2	200759901940	200759901760	200759901990	200759902020
AP100/1.7	200759901940	200759901760	200759901990	200759902020
AP100/2.5	200759901930 + washer 200530751672	200759901760	200759901990	200759902020
AP100/3.5		200759901940	200759901980	200759902020
AP100/4.3		200759901940	200759901980	200759901780
AP100/5		200759901940	200759901980	200759901780
AP100/6.5			200759901880	200759901780
AP100/8			200759901880	200759901780
AP100/10			200759901770	200759901860

Pump S609			Horizontal positions P01, P02, P03, P04		Vertical positions P15, P35, P25, P45	
			P-025Q-*	P-035Q-*	P-025Q-*	P-035Q-*
AP100/1.2 - AP100/4.3	P01	P03	200759900870	200759900880	200759900740	200759900780
	P02	P04	200657000050	200759900860		
AP100/1.2 - AP100/5	P01	P03	200759900870	200759900880	200759900740	200759900780
	P02	P04		200759900860		
AP100/1.2 - AP100/6.6	P01	P03		200759900880	200759900740	200759900780
	P02	P04		200759900860		
AP100/1.2 - AP100/8	P01	P03		200759901030	200546112009	200759901010
	P02	P04		200759901040		
AP100/1.7 - AP100/4.3	P01	P03	200759900870	200759900880	200759900740	200759900780
	P02	P04		200759900860		
AP100/1.7 - AP100/5	P01	P03	200759900870	200759900880	200759900740	200759900780
	P02	P04		200759900860		
AP100/1.7 - AP100/6.5	P01	P03		200759900880	200759900740	200759900780
	P02	P04		200759900860		
AP100/1.7 - AP100/8	P01	P03		200759901030	200546112009	200759901010
	P02	P04		200759901040		
AP100/2.5 - AP100/4.3	P01	P03	200759900870	200759900880	200759900740	200759900780
	P02	P04		200759900860		
AP100/2.5 - AP100/5	P01	P03		200759900880	200759900740	200759900780
	P02	P04		200759900860		
AP100/2.5 - AP100/6.5	P01	P03		200759901030	200546112009	200759901010
	P02	P04		200759901040		
AP100/2.5 - AP100/8	P01	P03		200759901030	200546112009	200759901010
	P02	P04		200759901040		
AP100/3.5 - AP100/5	P01	P03		200759900880	200546112009	200759901010
	P02	P04		200759900860		
AP100/3.5 - AP100/6.5	P01	P03		200759901030	200546112009	200759901010
	P02	P04		200759901040		
AP100/3.5 - AP100/8	P01	P03		200759901030	200546112009	200759901010
	P02	P04		200759901040		

4.1.2 Suction assembly kits for square tanks from 6 to 12 litres

Pump S309	Horizontal positions - P01, P02, P03, P04			
	P-060Q-**	P-080Q-**	P-100Q-**	P-120Q-**
AP100/1.2	200759901830	200759901830	200759901830	200759901830
AP100/1.7	200759901830	200759901830	200759901830	200759901830
AP100/2.5	200759901830	200759901830	200759901830	200759901830
AP100/3.5	200759901830	200759901830	200759901830	200759901830
AP100/4.3	200759901830	200759901830	200759901830	200759901830
AP100/5	200759901830	200759901830	200759901830	200759901830
AP100/6.5	200759901830	200759901830	200759901830	200759901830
AP100/8	200759901830	200759901830	200759901830	200759901830
AP100/10	200759901830	200759901830	200759901830	200759901830

Pump S309	Vertical positions - P15, P25, P35, P45			
	P-060Q-**	P-080Q-**	P-100Q-**	P-120Q-**
AP100/1.2	200759901790	200759902160	200759902050	200759901900
AP100/1.7	200759901790	200759902160	200759902050	200759901900
AP100/2.5	200759902020	200759901800	200759902050	200759901900
AP100/3.5	200759902020	200759901800	200759902050	200759901900
AP100/4.3	200759902020	200759901800	200759901810	200759901870
AP100/5	200759902020	200759901800	200759901810	200759901870
AP100/6.5	200759901780	200759902030	200759901810	200759901870
AP100/8	200759901780	200759902030	200759902040	200759901870
AP100/10	200759901780	200759902030	200759902040	200759901890

4.1.3 Suction assembly kits for round tanks from 6 to 14 litres

Pump S309	Horizontal positions - P01, P02, P03, P04				
	P-060R-**	P-080R-**	P-100R-**	P-120R-**	P-140R-**
AP100/1.2	200759901820	200759901820	200759901820	200759901820	200759901820
AP100/1.7	200759901820	200759901820	200759901820	200759901820	200759901820
AP100/2.5	200759901820	200759901820	200759901820	200759901820	200759901820
AP100/3.5	200759901820	200759901820	200759901820	200759901820	200759901820
AP100/4.3	200759901820	200759901820	200759901820	200759901820	200759901820
AP100/5	200759901820	200759901820	200759901820	200759901820	200759901820
AP100/6.5	200759901820	200759901820	200759901820	200759901820	200759901820
AP100/8	200759901820	200759901820	200759901820	200759901820	200759901820
AP100/10	200759901820	200759901820	200759901820	200759901820	200759901820

Pump S309	Vertical positions - P15, P25, P35, P45				
	P-060R-**	P-080R-**	P-100R-**	P-120R-**	P-140R-**
AP100/1.2	200759901970	200759901780	200759901790	200759902050	200759901900
AP100/1.7	200759901970	200759901780	200759901790	200759901810	200759901900
AP100/2.5	200759901970	200759901780	200759901790	200759901810	200759901900
AP100/3.5	200759901970	200759901860	200759901790	200759901810	200759901900
AP100/4.3	200759901770	200759901860	200759901790	200759901810	200759901870
AP100/5	200759901770	200759901860	200759902130	200759902040	200759901870
AP100/6.5	200759901770	200759902010	200759902130	200759902040	200759901870
AP100/8	200759901920	200759902010	200759901780	200759902040	200759901870
AP100/10	200759901960	200759901990	200759901780	200759902160	200759901890

4.2 Suction assembly kits for metal tanks

4.2.1 Suction assembly kits for square and round metal tanks from 5 to 18 litres

Pump S309	Horizontal positions - P01, P02, P03, P04					
	L-050R-01	L-080R-01	L-050R-02	L-080R-02	L-100R-01	L-180R-01
AP100/1.2	200759901910	200759901820	200759901910	200759901820	200759901850	200759901850
AP100/1.7	200759901910	200759901820	200759901910	200759901820	200759901850	200759901850
AP100/2.5	200759901910	200759901820	200759901910	200759901820	200759901850	200759901850
AP100/3.5	200759901910	200759901820	200759901910	200759901820	200759901850	200759901850
AP100/4.3	200759901910	200759901820	200759901910	200759901820	200759901850	200759901850
AP100/5	200759901910	200759901820	200759901910	200759901820	200759901850	200759901850
AP100/6.5	200759901910	200759901820	200759901910	200759901820	200759901850	200759901850
AP100/8	200759901910	200759901820	200759901910	200759901820	200759901850	200759901850
AP100/10	200759901910	200759901820	200759901910	200759901820	200759901850	200759901850

Pump S309	Vertical positions - P15, P25, P35, P45				
	L-050R-01	L-080R-01	L-070Q-01	L-120Q-01	L-150Q-01
AP100/1.2	200759901780	200759901780	200759901980	200759901990	200759901920
AP100/1.7	200759901860	200759901780	200759901980	200759901990	200759901920
AP100/2.5	200759901860	200759901780	200759901880	200759901990	200759901920
AP100/3.5	200759901860	200759901780	200759901880	200759901980	200759901960
AP100/4.3	200759902010	200759901780	200759901880	200759901980	200759901960
AP100/5	200759902010	200759901780	200759901970	200759901880	200759901960
AP100/6.5	200759902000	200759901860	200759901970	200759901880	200759901960
AP100/8	200759902000	200759902010	200759901920	200759901880	200759901760
AP100/10	200759901990	200759902010	200759901920	200759901770	200759901760

Pump S609			Horizontal positions - P01, P02, P03, P04					
			L-050R-01	L-080R-01	L-050R-02	L-080R-02	L-100R-01	L-180R-01
AP100/1.2	P01	P03	200759901200	200759901220	200759901200	200759901220	200759901230	200759900900
AP100/4.3	P02	P04	200759901190	200759901030	200759901190	200759901030	200759901250	200759900910
AP100/1.2	P01	P03	200759901200	200759901220	200759901200	200759901220	200759901230	200759900900
AP100/5	P02	P04	200759901190	200759901030	200759901190	200759901030	200759901250	200759900910
AP100/1.2	P01	P03	200759901200	200759901220	200759901200	200759901220	200759901230	200759900900
AP100/6.5	P02	P04	200759901190	200759901030	200759901190	200759901030	200759901250	200759900910
AP100/1.2	P01	P03	200759901210	200759901220	200759901210	200759901220	200759901230	200759900900
AP100/8	P02	P04	200759901190	200759901030	200759901190	200759901030	200759901250	200759900910
AP100/1.7	P01	P03	200759901200	200759901220	200759901200	200759901220	200759901230	200759900900
AP100/4.3	P02	P04	200759901190	200759901030	200759901190	200759901030	200759901250	200759900910
AP100/1.7	P01	P03	200759901200	200759901220	200759901200	200759901220	200759901230	200759900900
AP100/5	P02	P04	200759901190	200759901030	200759901190	200759901030	200759901250	200759900910
AP100/1.7	P01	P03	200759901200	200759901220	200759901200	200759901220	200759901230	200759900900
AP100/6.5	P02	P04	200759901190	200759901030	200759901190	200759901030	200759901250	200759900910
AP100/1.7	P01	P03	200759901210	200759901220	200759901210	200759901220	200759901230	200759900900
AP100/8	P02	P04	200759900870	200759901030	200759900870	200759901030	200759901250	200759900910
AP100/2.5	P01	P03	200759901200	200759901220	200759901200	200759901220	200759901230	200759900900
AP100/4.3	P02	P04	200759901190	200759901030	200759901190	200759901030	200759901250	200759900910
AP100/2.5	P01	P03	200759901200	200759901220	200759901200	200759901220	200759901230	200759900900
AP100/5	P02	P04	200759901190	200759901030	200759901190	200759901030	200759901250	200759900910
AP100/2.5	P01	P03	200759901210	200759901220	200759901210	200759901220	200759901230	200759900900
AP100/6.5	P02	P04	200759901190	200759901030	200759901190	200759901030	200759901250	200759900910
AP100/2.5	P01	P03	200759901210	200759901220	200759901210	200759901220	200759901240	200759900900
AP100/8	P02	P04	200759900870	200759901030	200759900870	200759901030	200759901250	200759900910
AP100/3.5	P01	P03	200759901210	200759901220	200759901210	200759901220	200759901230	200759900900
AP100/5	P02	P04	200759900870	200759901030	200759900870	200759901030	200759901250	200759900910
AP100/3.5	P01	P03	200759901210	200759901220	200759901210	200759901220	200759901230	200759900900
AP100/6.5	P02	P04	200759900870	200759901030	200759900870	200759901030	200759901250	200759900910
AP100/3.5	P01	P03	200759901210	200759901220	200759901210	200759901220	200759901240	200759900900
AP100/8	P02	P04	200759900870	200759901030	200759900870	200759901030	200759901250	200759900910

Pump S609		Vertical positions - P15, P25, P35, P45			
		L-050R-01	L-080R-01	L-070Q-01	L-120Q-01
AP100/1.2	AP100/4.3	200759900970	200759901120	200546112009	200759900740
AP100/1.2	AP100/5	200759900970	200759901120	200546112009	200759900740
AP100/1.2	AP100/6.5	200759900970	200759900790		200546112009
AP100/1.2	AP100/8	200759901140	200759901010		200546112009
AP100/1.7	AP100/4.3	200759900970	200759901120	200546112009	200759900740
AP100/1.7	AP100/5	200759900970	200759900790		200759900740
AP100/1.7	AP100/6.5	200759900970	200759900790		200546112009
AP100/1.7	AP100/8	200759901140	200759900980		200546112009
AP100/2.5	AP100/4.3	200759900970	200759900790		200759900740
AP100/2.5	AP100/5	200759900970	200759900790		200546112009
AP100/2.5	AP100/6.5	200759901140	200759901010		200546112009
AP100/2.5	AP100/8	200759901140	200759900980		200546112009
AP100/3.5	AP100/5	200759900650	200759900970		200546112009
AP100/3.5	AP100/6.5	200759901140	200759900980		200546112009
AP100/3.5	AP100/8	200759901090	200759900980		200546112009

4.3 Accessories

4.3.1 Filter conveyor: standard

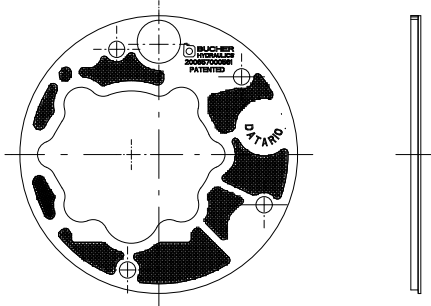

Filter conveyor
PATENTED
 Assembled on the return line
 Plastic material
 Polyester filter area
 150 micron filtering net
 Fixed directly on the housing
 Seal for the pump body.
 Code: 200657000561

The internal shape of the filtering conveyor replaces the external profile of the gear pump as well as the external profile matches the internal diameter of the tank spigot. The main feature of the filtering conveyor is to collect all returns avoiding oil-foam effects, possible small clearances between the internal and external above profiles have to be judged as normal referring 150 micron size to the filtering net capacity, only.

4.3.2 Filter conveyor : special applications

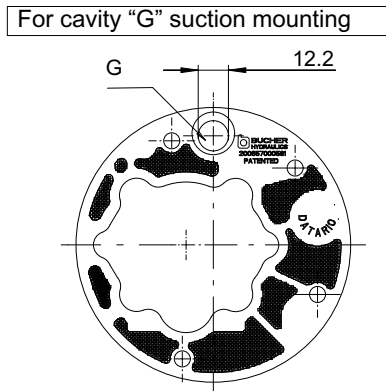

Filter conveyor code: 200657000610

Suction tube code:
200785000200

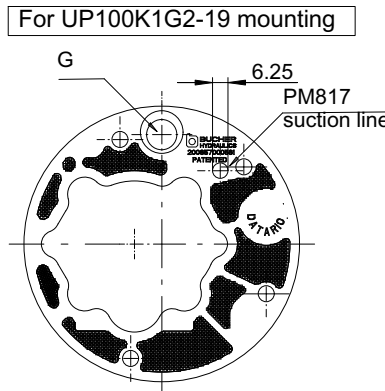
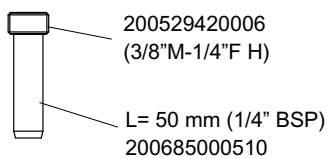

Filter conveyor code: 200657000620

Return tube for G cavity used
for UP100K1G2-19 mounting
Code: 200785000200

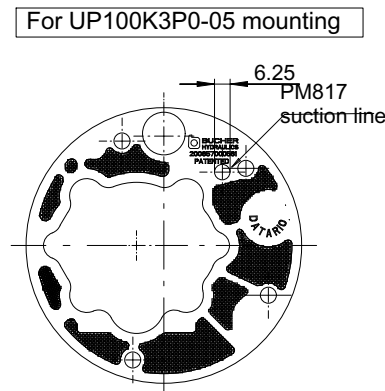

Filter conveyor code: 200657000630

Suction tube for PM817 suction line used for
UP100K1G2-19 and UP100K3P0-05 mounting

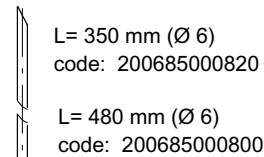

4.3.3 Suction filter

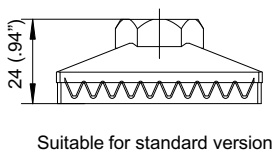

Suction plastic filter
 Square: 59 mm
 Filtering: 216 micron
 Thread: 3/8" BSP - Female
 Code: 200546112025

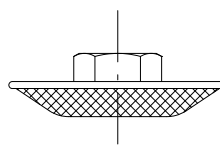

Suction steel filter
 Diameter: 60 mm.
 Filtering: 250 micron
 Thread: 3/8" BSP - Female
 Code: 200546112008

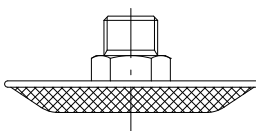

Suction steel filter
 Diameter: 80 mm.
 Filtering: 250 micron
 Thread: 3/8" NPT - Male
 Code: 200546112009

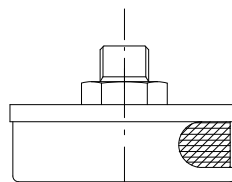

Suction steel filter
 Diameter: 80 mm.
 Filtering: 60 micron
 Thread: 3/8" NPT
 Code: 200657000050 (Male)
 200657000060 (Female)

5 Electric motors

Electric motor available:

5.1 D.C. motors

Generally used for mobile applications

5.2 A.C. motors

Generally used for stationary applications

5.1 D.C. motors

5.1.1 Technical information

Available versions:

Voltage: 12-24 and 48 V

Power rating: 0.8 ÷ 3 kW.

For different input voltage and power rating, consult our Sales Department.

Direction of rotation:

Unless otherwise stated, all motors are specified clockwise rotation, suitable for driving counterclockwise pump.

Type of winding:

D.C. motors can be manufactured in different types of field windings:

- Permanent magnets
- Series
- Compound

Permanent magnets

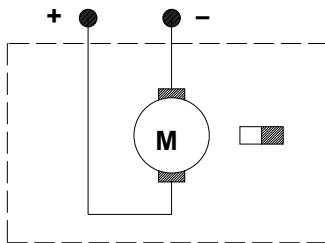

Series

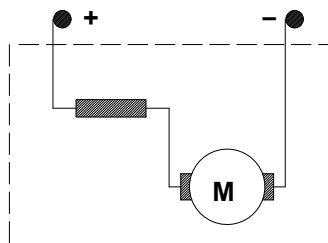

Compound

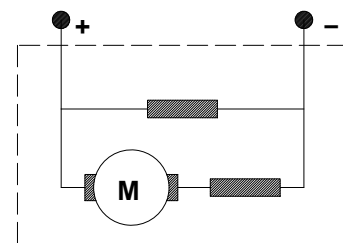

Insulation class:

The class of electric insulation reflects the maximum temperature the motor can register during operation without damage to the insulating material internally of the motor itself.

The following table indicates insulation classes to CEI 15-26.

Class	Y	A	E	B	F	H
Temperature (°C)	90	105	120	130	155	180

Type of duty:

To ensure selection of the electric motor best suited to a given set of operating conditions, the duty cycle needs to be verified. Duty cycles S1, S2 and S3 are defined below in accordance with CEI 2-3

Continuous duty S1:

Operation on-load (steady conditions) for a period of indefinite duration, during which the motor reaches thermal equilibrium without exceeding the maximum permissible temperature.

Short time duty S2

Operation on-load (steady conditions) for a period of limited duration, denoted t_d in the diagram, during which maximum permissible temperature is reached, followed by an off-load period of duration sufficient for the temperature of the motor to return to ambient temperature.

Intermittent duty S3

A sequence of identical cycles, each 10 minutes in duration, the single cycle comprises a period of operation on-load t_d , during which the motor may reach its maximum permissible temperature, is reached, followed by an off-load period of limited duration t_m , insufficient for the temperature of the motor to return to ambient temperature.

The value of S3 indicates the duration of the on-load period t_d in relation to the overall cycle time t_p , as a percentage.

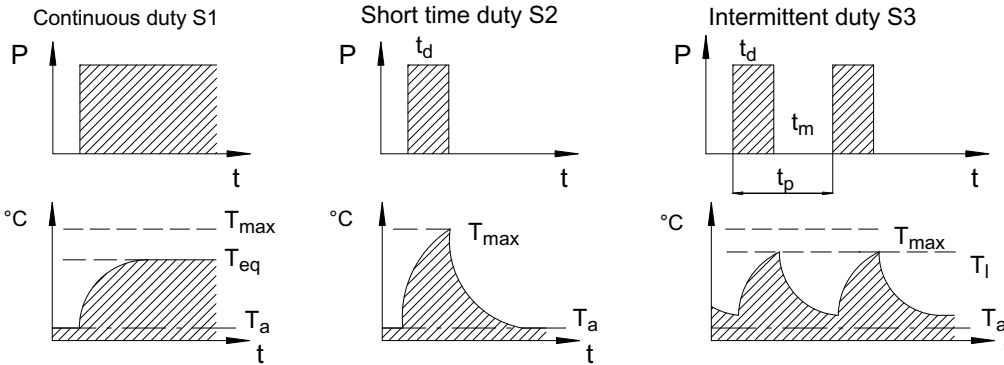

$$S3 = \frac{t_d}{t_d + t_m} \times 100$$

- P = load
- T_{eq} = temperature at thermal equilibrium
- T_{max} = maximum permissible temperature
- T_l = operating temperature
- T_a = ambient temperature
- t_d = duration of on-load period
- t_m = duration of off-load period
- t_p = duration of cycle (10 min.)

Degree of protection:

This indicates the level of protection afforded in preventing contact between live parts of the motor and people or foreign matter generally, and preventing the penetration of water.

The degree of protection is indicated in accordance with CEI 2-16 by the initials IP and two identifying digits:

Example:

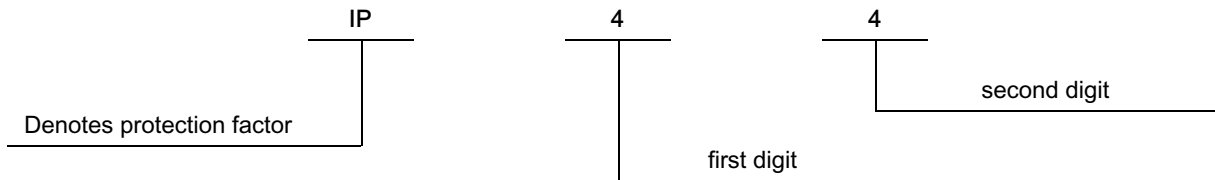

The first digit indicates the degree of protection afforded to the motor against contact with people or foreign bodies.

The second digit indicates the degree of protection afforded to the motor against the effects of penetration by water.

0	no protection	0	no protection
1	protection against solid bodies measuring > 50 mm	1	protection against water dripping vertically
2	protection against solid bodies measuring > 12 mm	2	protection against water dripping at 15° max
3	protection against solid bodies measuring > 2.5 mm	3	protection against rain
4	protection against solid bodies measuring > 1 mm	4	protected against water splash
5	protection against dust	5	protected against water spray

The degree of protection indicated for each individual electric motor, refers to the motor when mounted to a Bucher Hydraulics S.p.A. power pack.

5.1.2 Characteristic curves

Characteristic curves are given for each motors, from which to establish pressure, flow rate and current

consumption values, and S2 and S3 duty cycles.

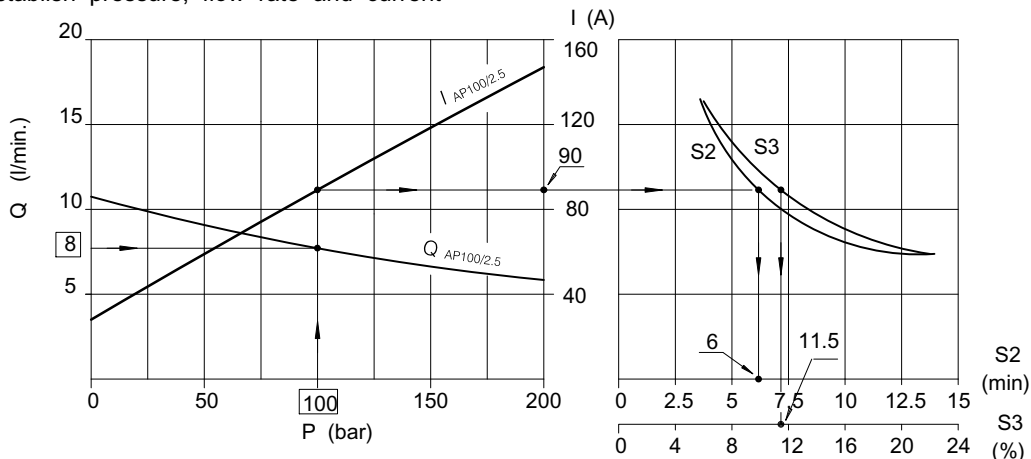

5.1.3 Example of how the graphs are used

Required data

Flow rate $Q = 8 \text{ l/min}$

Pressure $p = 100 \text{ bar}$

Pump displacement

Determined by the intersection of the required p and Q curves.

In the example indicated, pump AP100/2.5 has the required p and Q specifications.

In the event that there is no point of intersection with any curve, a displacement as near as possible to the required flow rate should be selected.

Current consumption

This is determined by taking a vertical line from the pressure value to its point of intersection with the I curve corresponding to the selected displacement.

In the example illustrated, current consumption is:

$I = 90 \text{ Ampere}$

Type of use

Having established the current, the relationship of the $S2$ and $S3$ curves will give the following values:

$S2 = 6 \text{ min.}$ $S3 = 11.5\%$

Terminals

Unless otherwise stated, d.c. motors supplied by Bucher Hydraulics S.p.A. have two terminals.

Poles are identified in accordance with IEC34-8

A1 - A2 Armature

D1 - D2 Series

B1 - B2 Poles

E1 - E2 Parallel

Electric diagram

A typical arrangement for connection of the motor to the power supply is shown in the diagram.

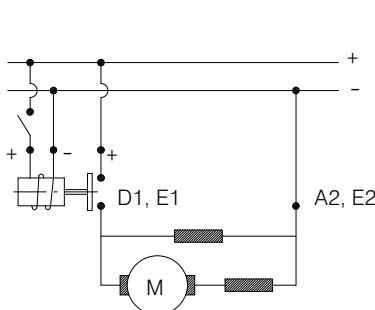

Versions available on request

1. Motors with electrical device monitoring brush wear
2. Motors with thermocouple
3. Fan-cooled motors

Fan-cooled motors, 12 and 24 volt, are available, for

200 - P - 991214 - E - 13/03.13
UP100

5.1.4 Mounting directions



The tie bolts must not be withdrawn completely while fitting motor, but retracted just for a short distance (30-50 mm max).

Once fitted to the power pack, the motor should be run off-load momentarily (5 seconds max) to verify its correct operation: supply power to the windings and measure the current drain, which must not exceed the following values:

24 V motor - $I < 35 \text{ Ampere}$

12 V motor - $I < 70 \text{ Ampere}$

Power cable

The wire selected for power connections must be of cross section appropriate for the rated current of the motor.

Tightening torques

When assembling the motor and power pack and securing the wires of the power cable to the motor terminals, observe the tightening torque values indicated.

Brush life

The brushes will wear down progressively with continued operation of the motor, and must be replaced when reduced to their minimum useful length.

Since the rate of wear on the brushes is dictated by the operating conditions and cannot therefore be broadly specified, consult our Sales Department for guidance.

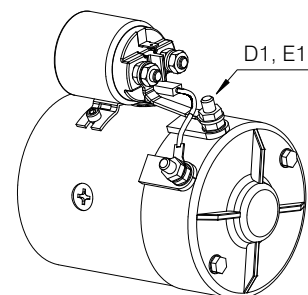
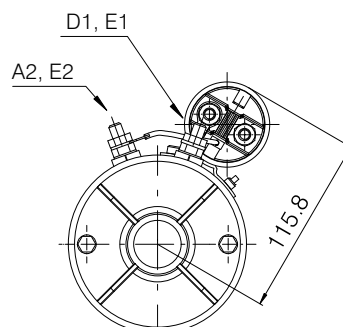

further information, consult our Sales Department.

Bucher Hydraulics S.p.A. is not an electric motors manufacturer so these components come from third part. Bucher Hydraulics S.p.A. reserves the right to change the motor supplier whenever considers it necessary without notice

Voltage	Nominal Power
12 V	800 W
24 V	800 W

Protection index: IP54
 Insulation class: F
 Type of winding: Permanent magnets
 Relay fixing kit 200709000090
 Minimum brushes length: 5 mm (0.2 inches)

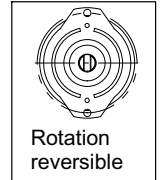
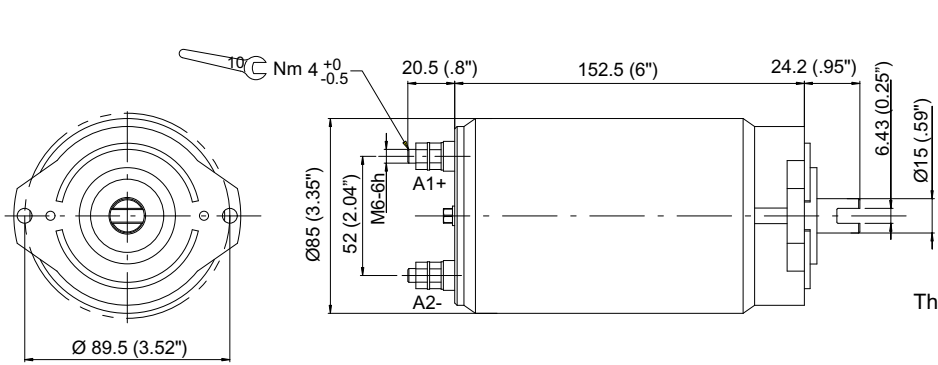

Attention!
Verify the connection.
The motor must rotate clockwise

Weight: 3.70 Kg (8.15 lb)

Rotation reversible	Motor		Motor with relay	
	12V-800W	24V-800W	12V-800W	24V-800W
Type	C128PK/A0	C228PK/A0	C128PK/A0 + R109	C228PK/A0 + R215
Code	200543912809	200543922801	200763310270	200763320300
Relay			Standard	
Relay type			R109	R215

Motor mounting position

Standard positions

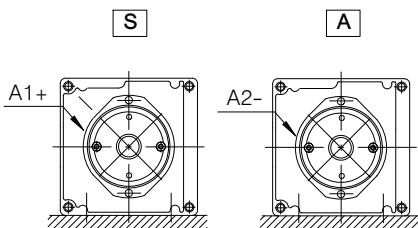

5	C	2	2	8	P	K	/	A	1	S
---	---	---	---	---	---	---	---	---	---	---

Example

	R	2	1	5	F					

Relay mounting positions

Standard positions

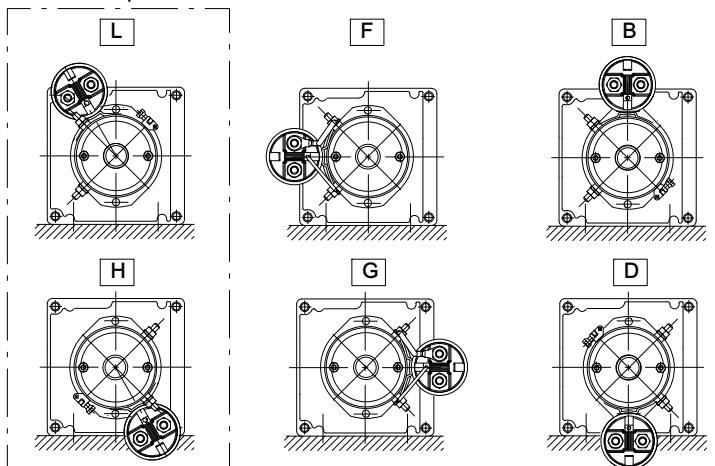

12 V - 800 W

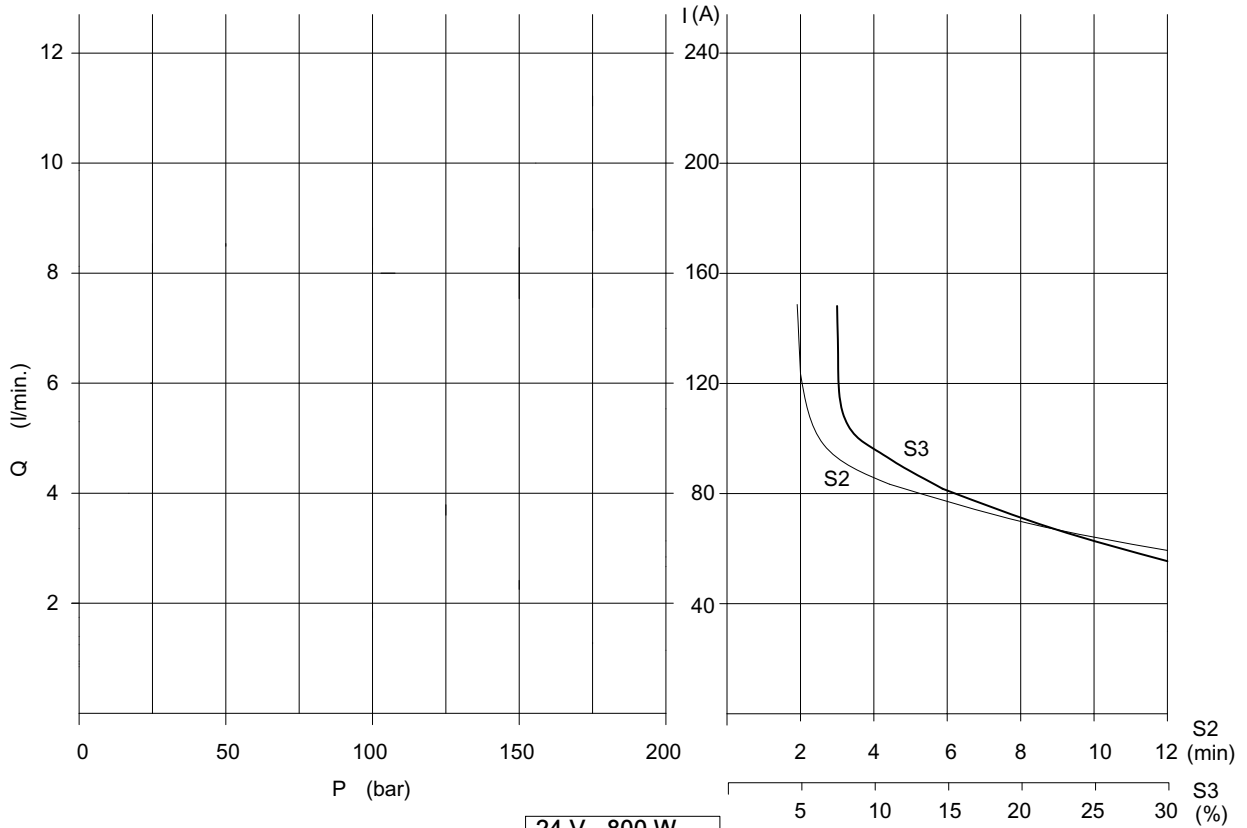

24 V - 800 W

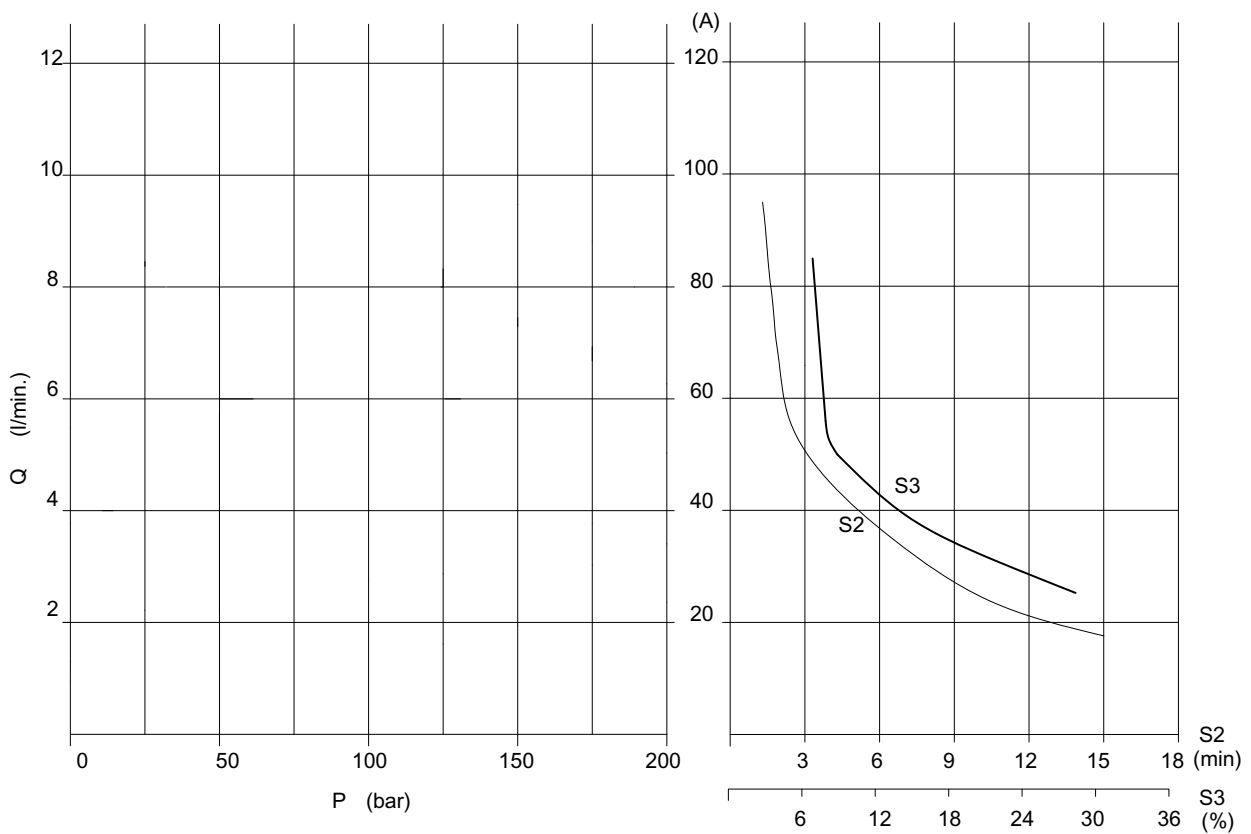

Voltage	Nominal Power
12 V	1600 W
24 V	2200 W

Protection index: IP44
 Insulation class: F
 Type of winding: Compound
 Brushes kit: (12/1600) 200544138022
 (24/2200) 200544138023
 Minimum brushes length: 12.5 mm (0.5 inches)

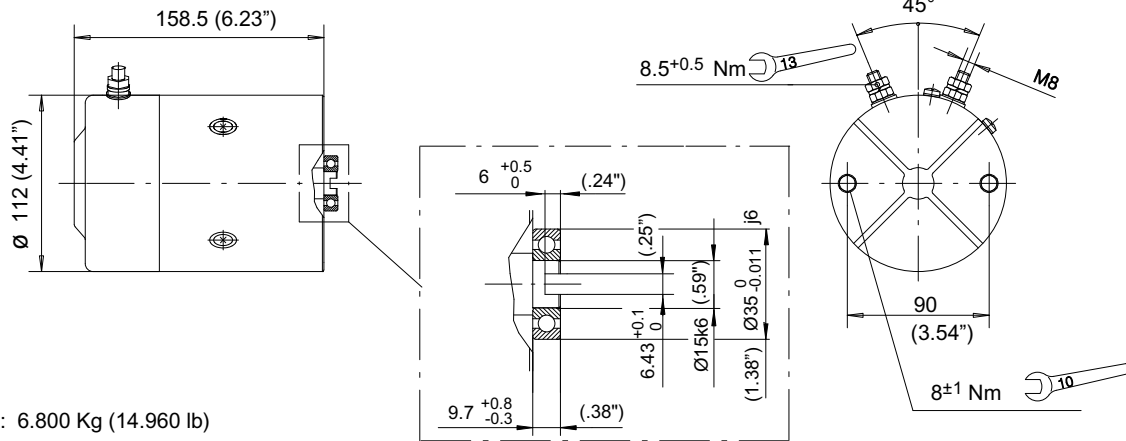

Weight: 6.800 Kg (14.960 lb)

Rotation Right	Motor		Motor with relay	
Type	C135AB/H0	C240AB/S0	C135AB/H0 +R109	C240AB/S0 +R215
Code	200543913706	200543924007	200763310240	200763320330
Relay	Standard			
Relay type			R109	R215

Motor mounting positions

Standard positions

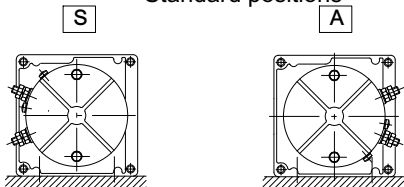

Standard positions

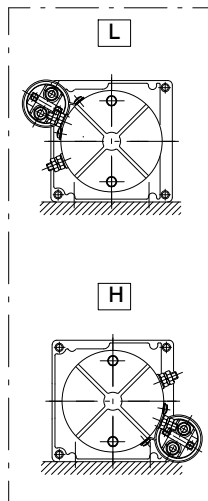

Relay mounting positions

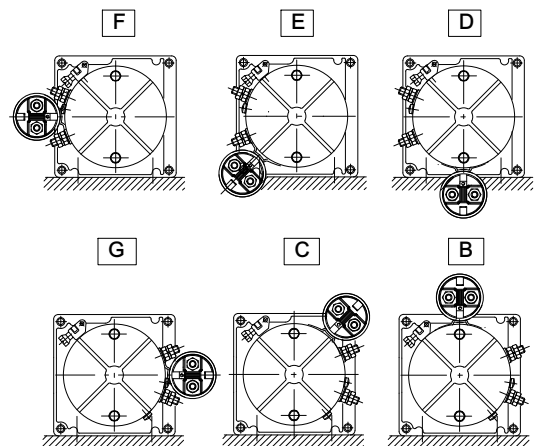

5	C	1	3	5	A	B	/	H	1	S
---	---	---	---	---	---	---	---	---	---	---

Example

R	1	0	9	L
---	---	---	---	---

12 V - 1600 W

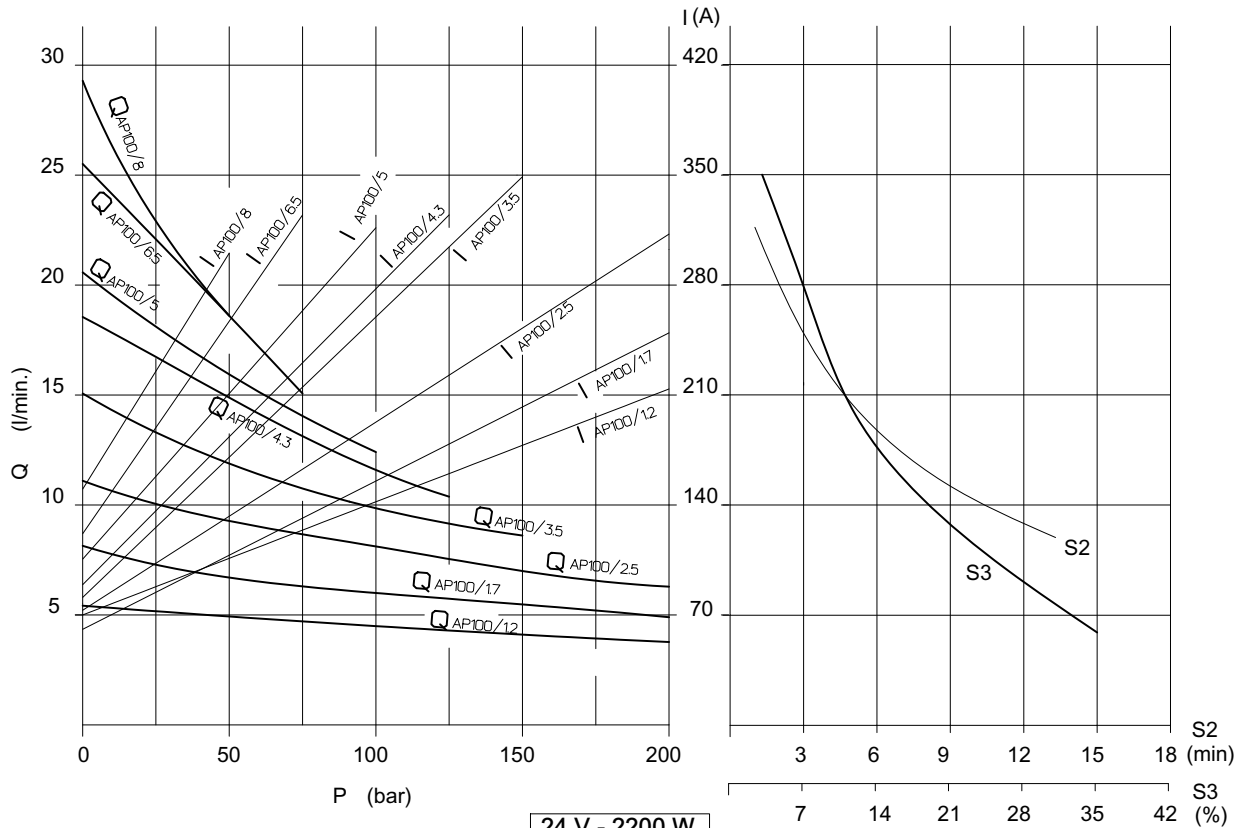

24 V - 2200 W

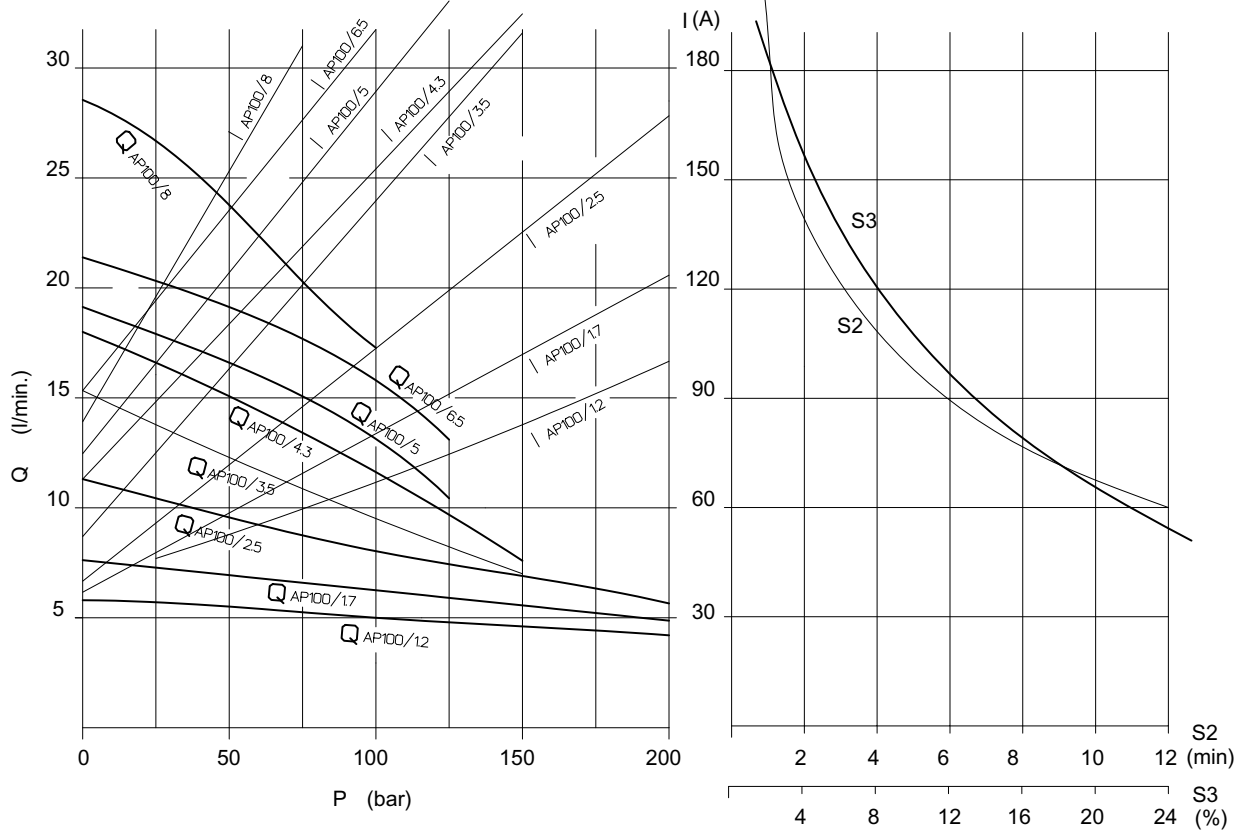

Voltage	Nominal Power
12 V	1500 W
24 V	2000 W

Protection index: IP54
 Insulation class: F
 Type of winding: Compound
 Brushes kit: (12/1500) 200544138016
 (24/2000) 200544138015
 Minimum brushes length: 12.5 mm (0.5 inches)

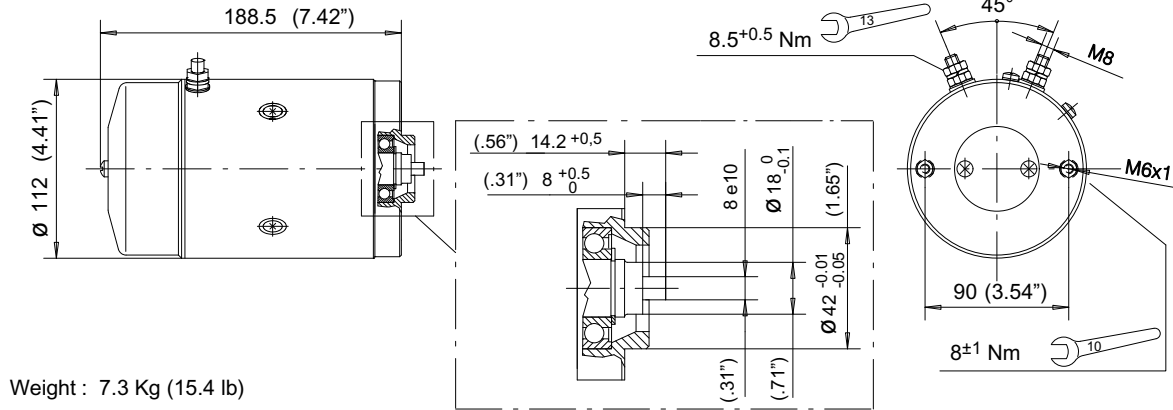

Weight : 7.3 Kg (15.4 lb)

	Motor		Motor with relay				
Rotation Right							
Type	C134AK/O0	C238AK/P0	C134AK/O0 + R109	C238AK/P0 + R215			
Code	200543913416	200543923813	200763310260	200763320250			
Relay			Standard				
Relay type			R109	R215			

Motor mounting positions

Standard positions

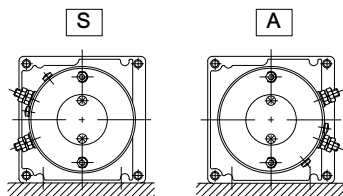

Standard positions

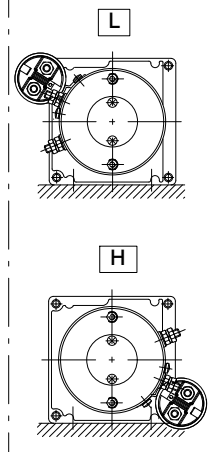

Relay mounting positions

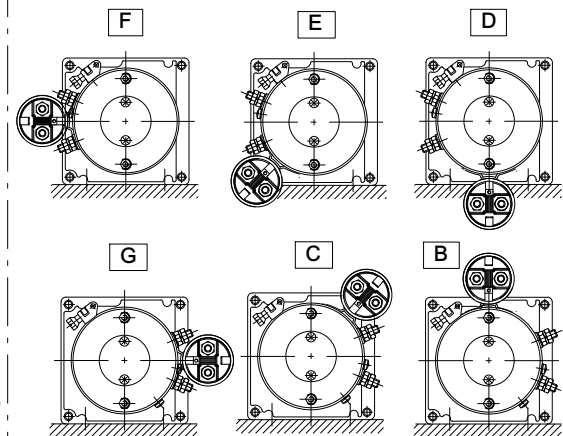

	Electric motor						Pos.
5	C	1	3	4	A	K / O 0	S
Example							
	Relay						Pos.

12 V - 1500 W

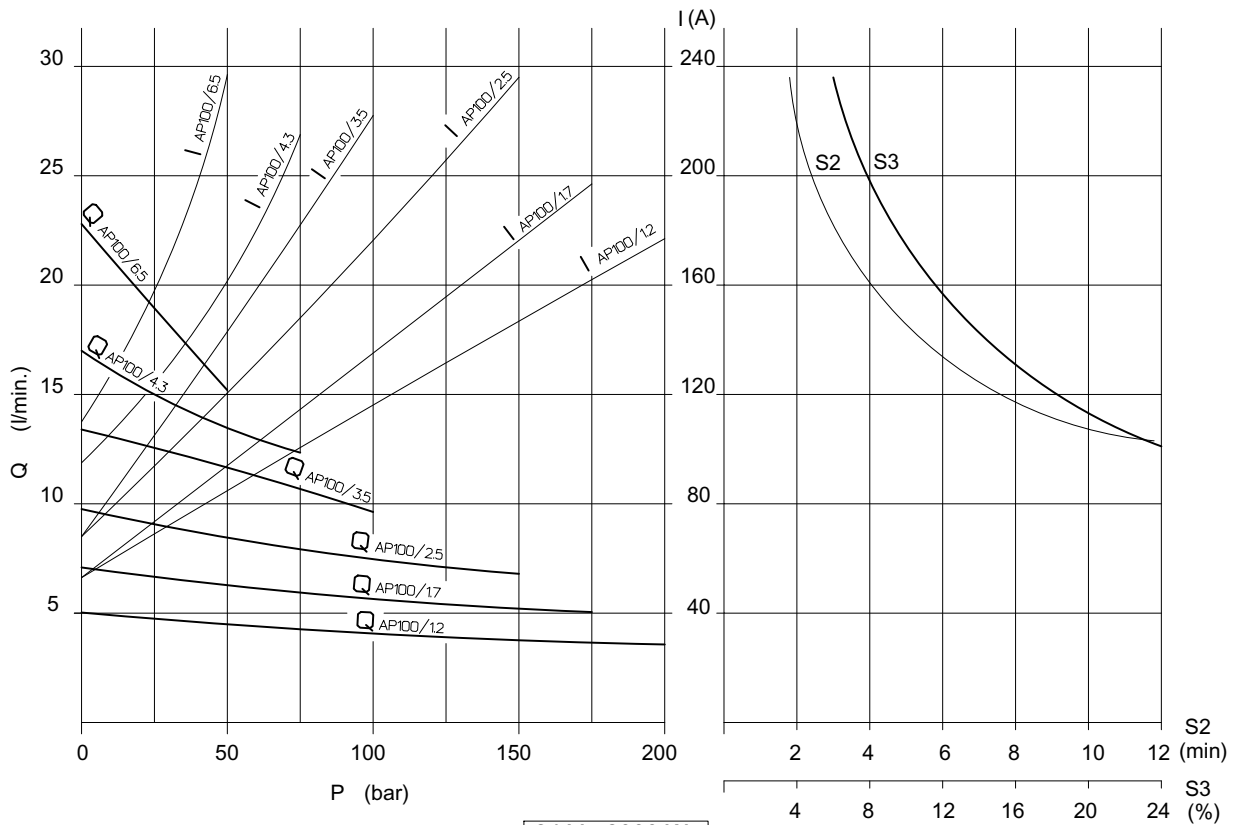

24 V - 2000 W

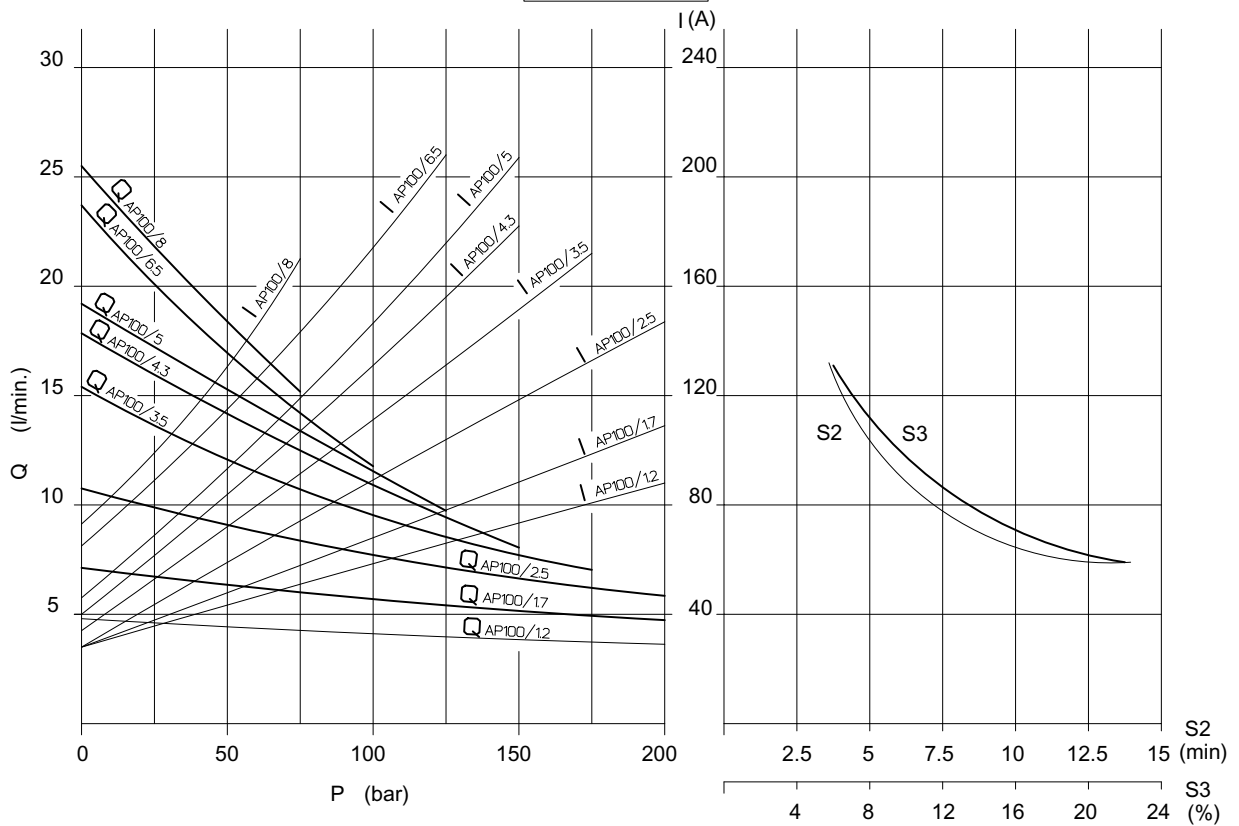

Voltage	Nominal Power
12 V	1700 W
24 V	2200 W

Protection index: IP44
 Insulation class: B
 Type of winding: Compound
 Brushes kit: (12/1700) 200544138012
 (24/2200) 200544138012
 Minimum Brushes length: 5 mm (0.2 inches)

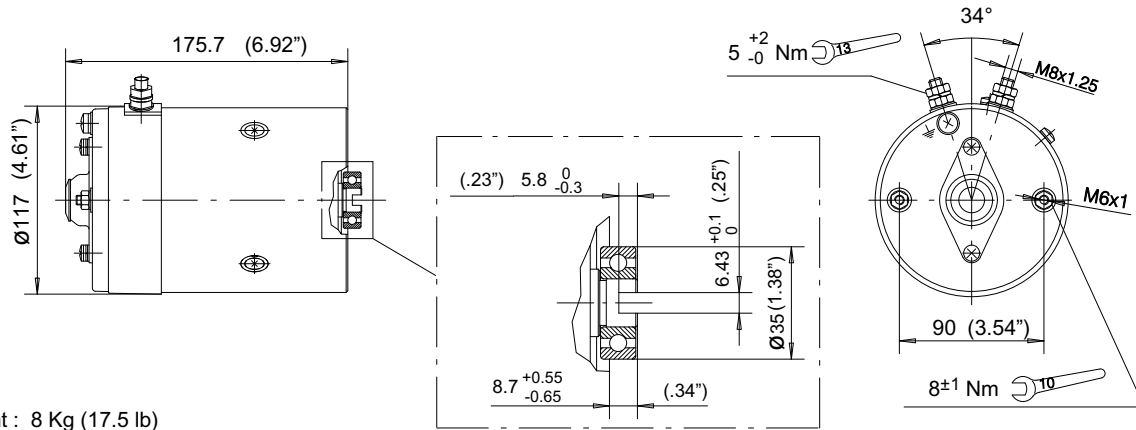

Weight : 8 Kg (17.5 lb)

	Motor		Motor with relay			
	Rotation Right					
Type	T107E	T109E	T107E +R109	T109E +R215		
Code	200543913806	200543924205	200763310210	200763320290		
Relay			Standard			
Relay type			R109	R215		

Motor mounting positions

Standard positions

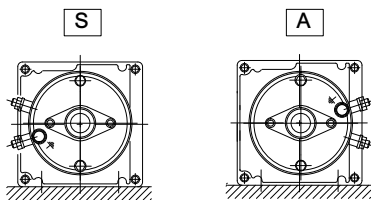

Standard positions

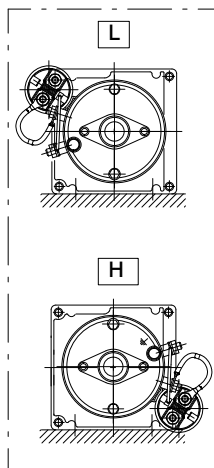

Relay mounting positions

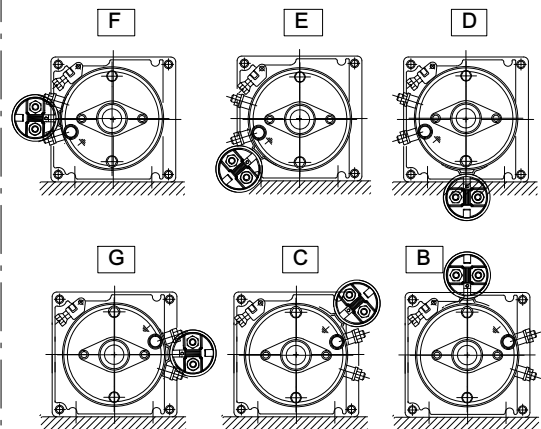

Electric motor										Pos.
5	T	1	O	9	E					S
Relay										Pos.

12 V - 1700 W

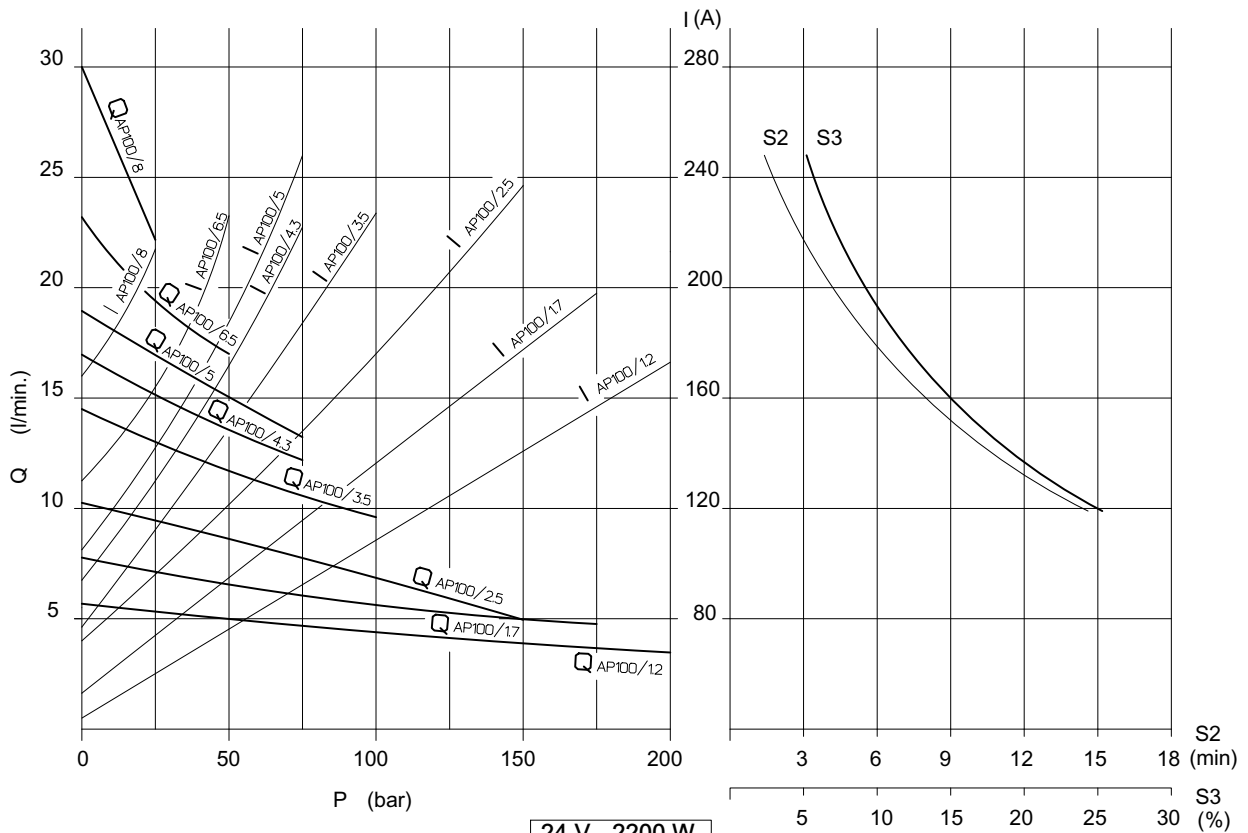

24 V - 2200 W

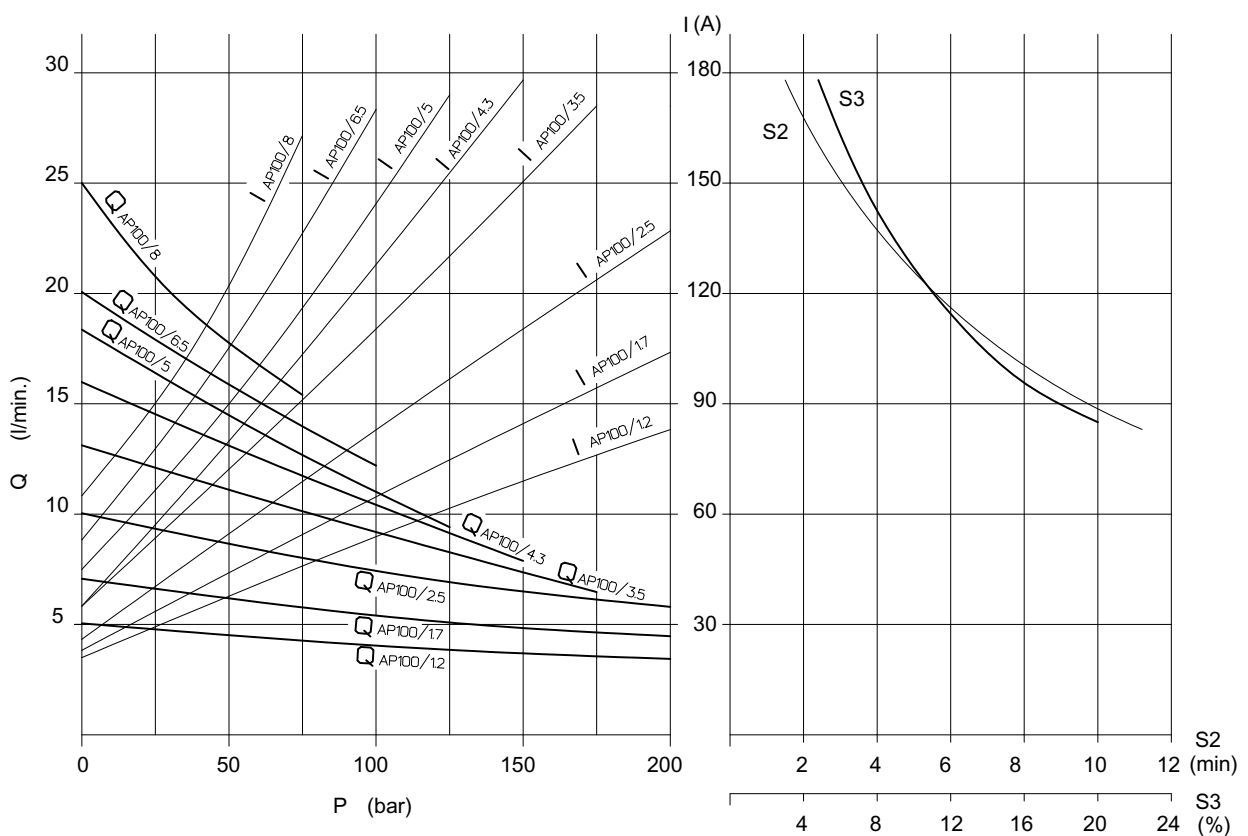

Voltage	Nominal Power
48 V	2000 W

Protection index: IP54
 Insulation class: F
 Type of winding: Compound
 Brushes kit: 200544138018
 Minimum brushes length: 12.5 mm (0.5 inches)

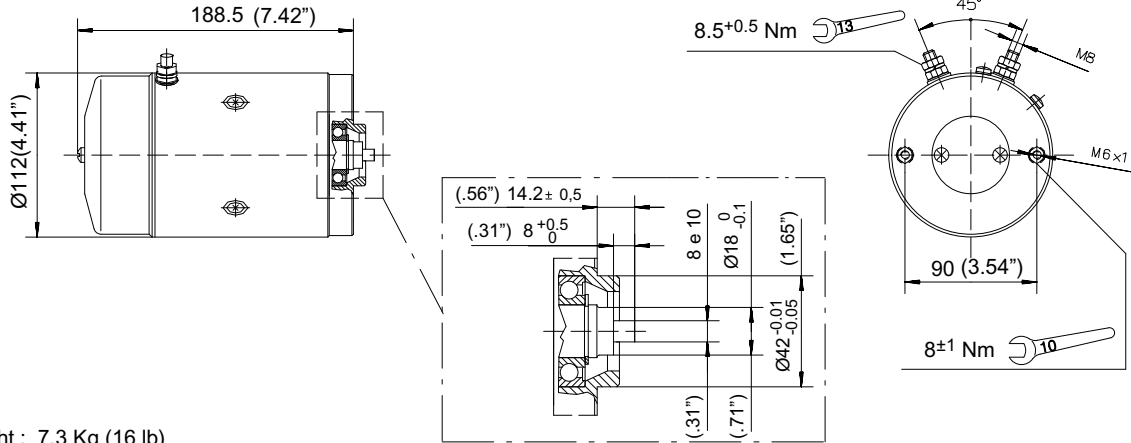

Weight : 7.3 Kg (16 lb)

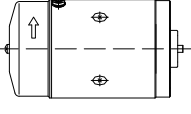
	Motor	Motor with relay			
Rotation Right					
Type	T82K				
Code	200543933803				
Relay					
Relay type					

Motor mounting positions

Standard positions

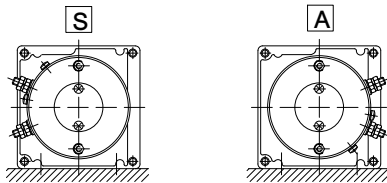

	Electric motor						Pos.
5	T	8	2	K			S

Example

	Relay				Pos.

48 V - 2000 W

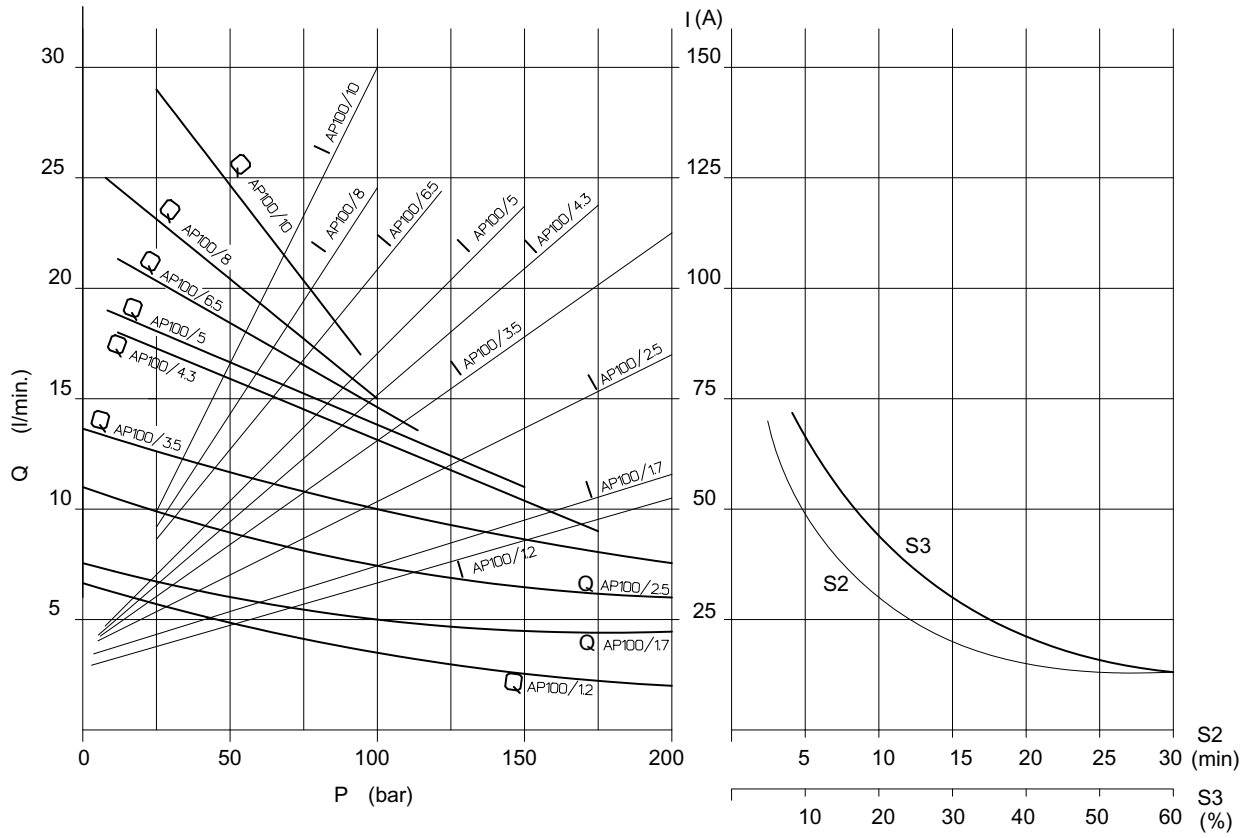

Voltage	Nominal Power
24 V	3000 W

Protection index: IP44
 Insulation class: F
 Type of winding: Compound
 Brushes kit: 200544138011
 Minimum brushes length: 15 mm (0.6 inches)

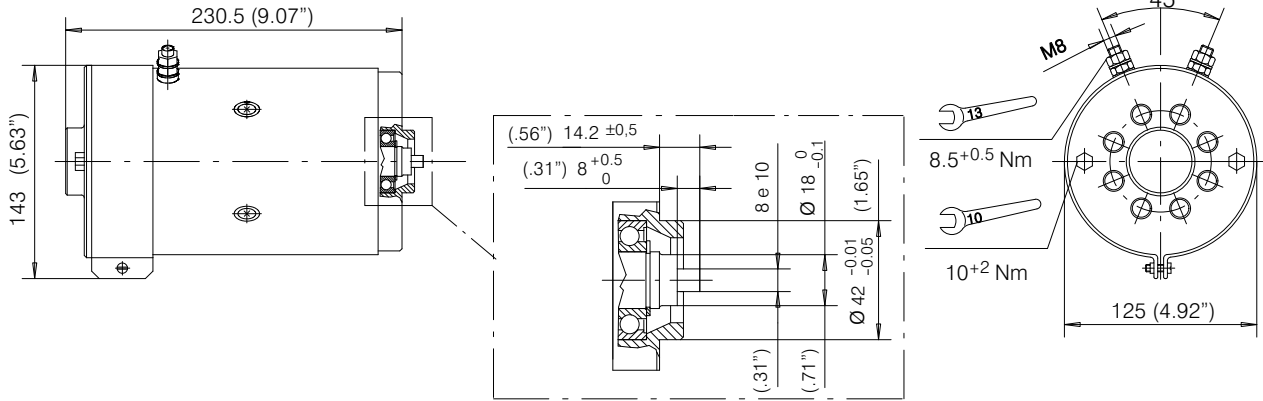

Weight : 12 Kg (26.4 lb)

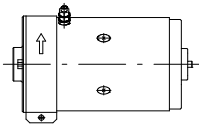
	Motor	Motor with relay	
Rotation Right			
Type	T106K		
Code	200543924806		
Relay			
Relay type			

Motor mounting position
Standard positions

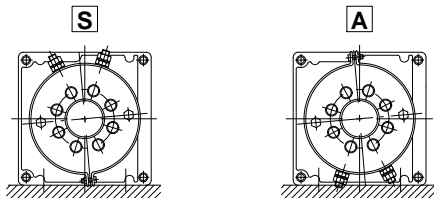

Example

	Electric motor					Pos.	Relay		Pos.
5	T	1	0	6	K	S			

24 V – 3000 W

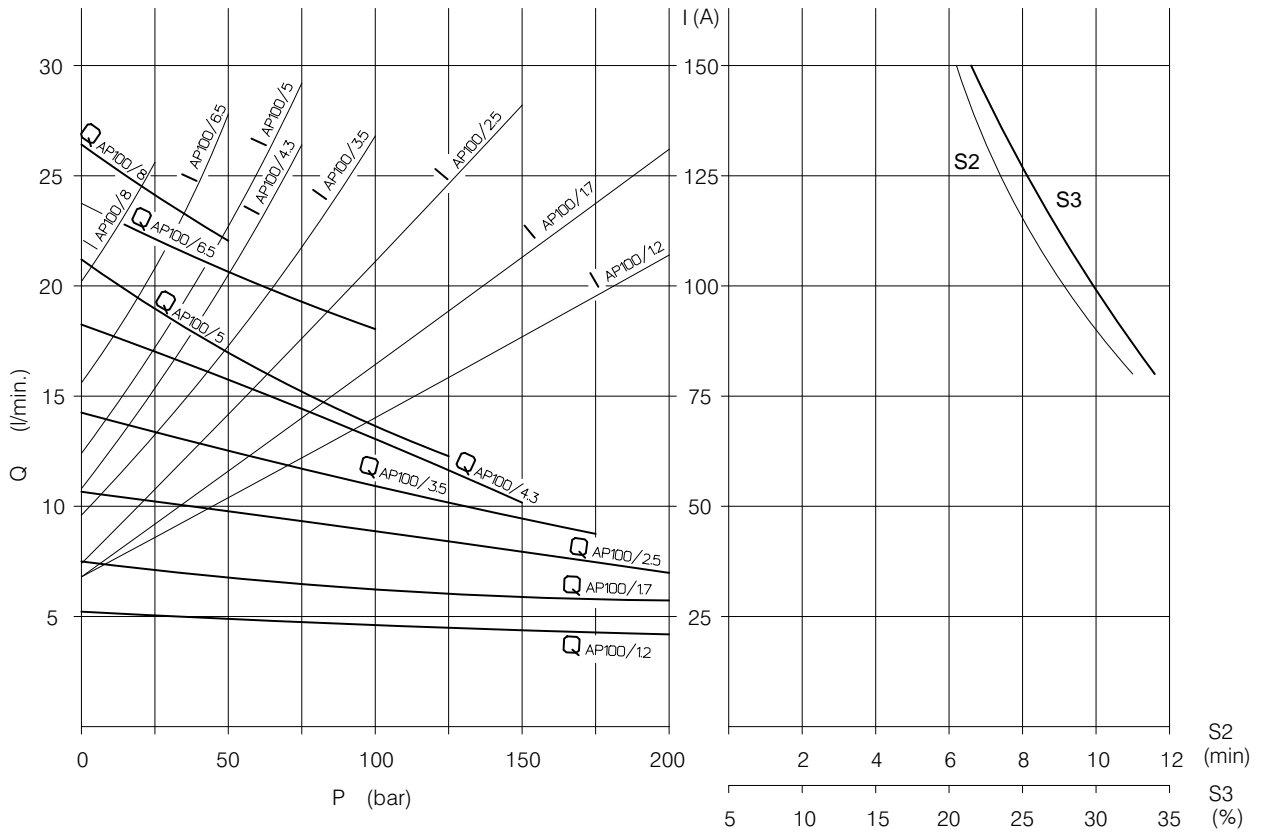

Voltage	Nominal Power
24 V	3000 W

Protection index: IP43
 Insulation class: F
 Type of winding: Compound
 Brushes kit: 200544138029
 Minimum brushes length: 15 mm (0.6 inches)

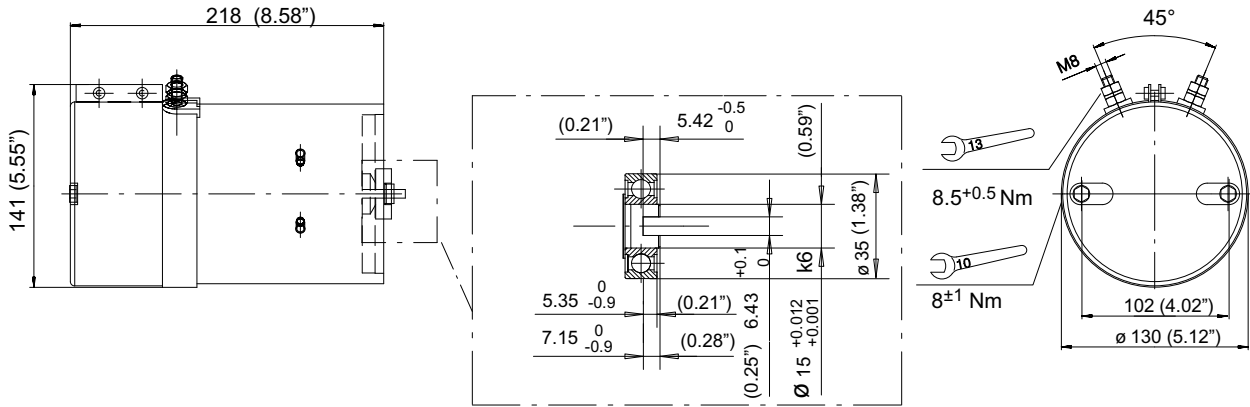

Weight : 12 Kg (26.4 lb)

	Motor	Motor with relay
Rotation Right		
Type	24 V - 3000 W C248AK/Z0	24 V - 3000 W C248AK/Z1
Code	200543924601	200543924602
Relay		Heavy duty
Relay type		R212 Standard positions only

Motor mounting position
Standard positions

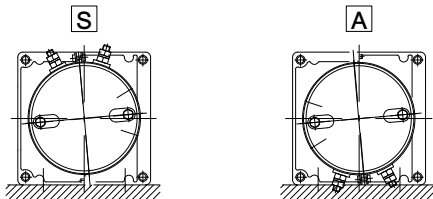

Relay mounting positions
Standard positions

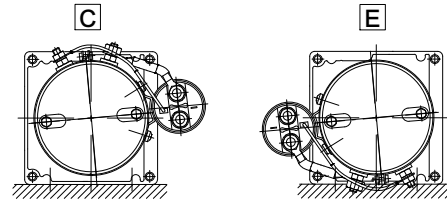

Example

	Electric motor							Pos.	Relay				Pos.		
5	C	2	4	8	A	K	/	Z	0	S					

24 V - 3000 W

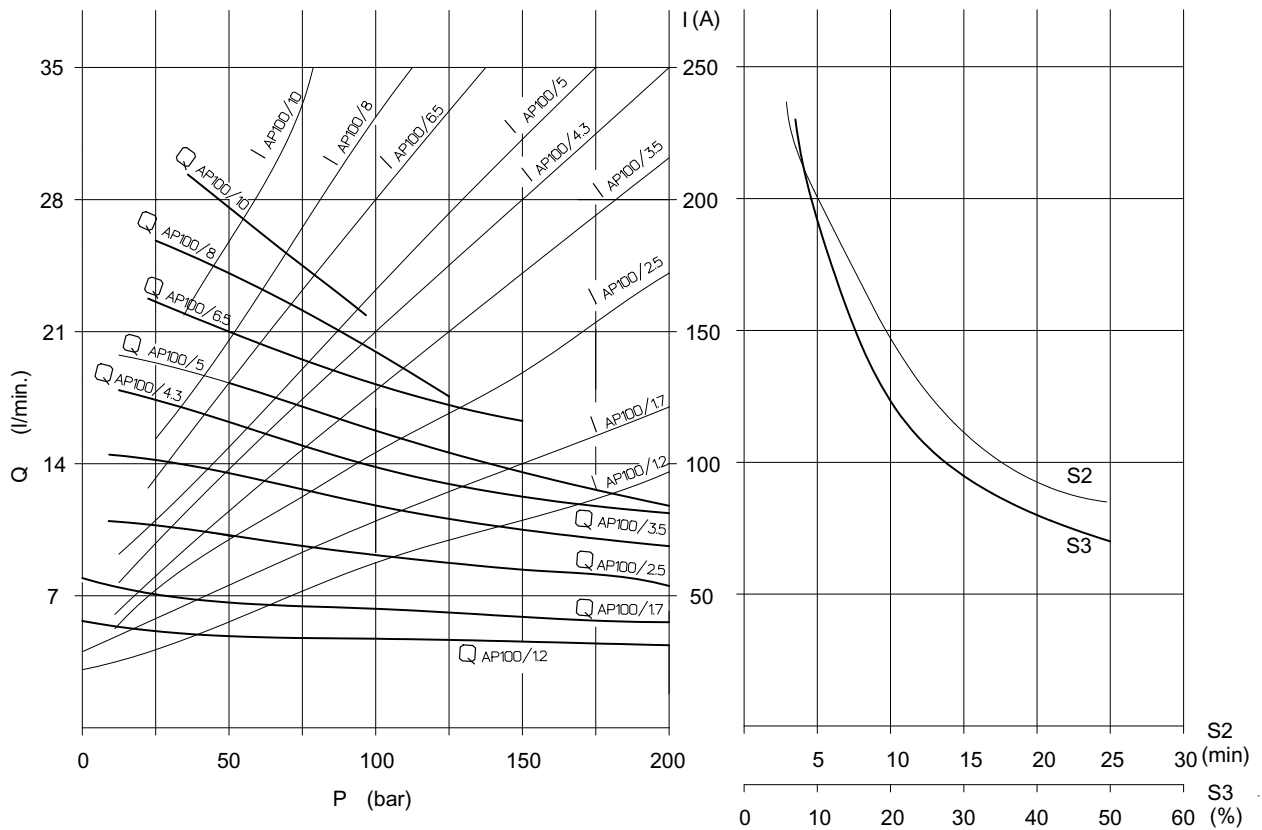

5.1.5 Starter Relays - Technical information

Versions:

Available voltage: 12-24 V

Standard: suitable for most applications.

Heavy duty: for more arduous conditions

See relative table for technical data for:

- Electrical insulation class

- Type of duty

- Protection factor:

The level of protection is defined according to the same parameters as listed for electric motors.

- Contact life:

The contacts of the relay will wear down progressively during operation.

Since the rate of wear is dedicated by the type of duty and cannot therefore be broadly specified, consult our Sales dept. for guideline information.

Fitment to electric motor

Starter relays can be fitted to the frame of the motor by two different methods:

1. Direct

The relay is secured with screws, using holes already tapped in motor frame. In this instance there is one standard mounting position only.

2. Metal clip

Suitable for standard relays only.

The relay is secured by means of a clip encircling the motor frame and inserted through special slots in the feet of the relay itself.

In this instance, several mounting positions are possible.

Electrical diagram

A typical arrangement for connection of the relay to the electric motor is shown in the diagram.

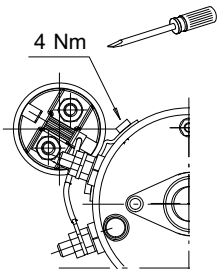

Direct fixing

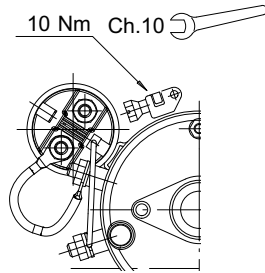

Fixing with clip

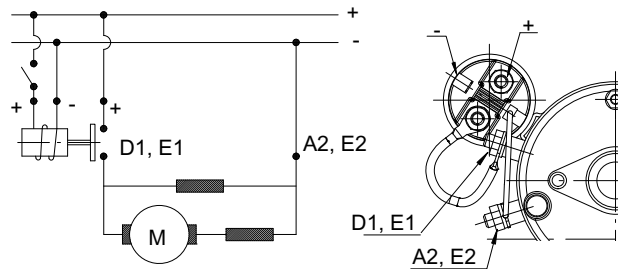

Electric diagram

Heavy duty (STANDARD for wide range of DC el. motors)

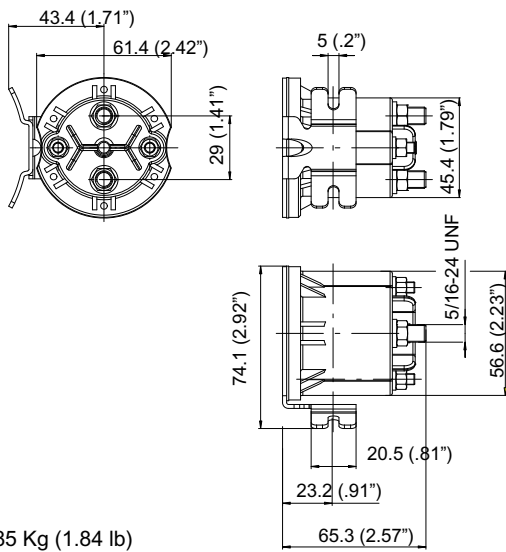

Weight : 0.85 Kg (1.84 lb)

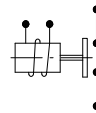
Voltage	12 V	24 V
Type	R109	R215
Code	200544134109	200544134215
Amps Consumption by the coil	2.2 A	1.2 A
Current for continuous duty		150 A
Max. current (5 sec.)		800 A
Protection index		IP66
Insulation class		F
Electric diagram		

Heavy duty (3000 W. el. motors)

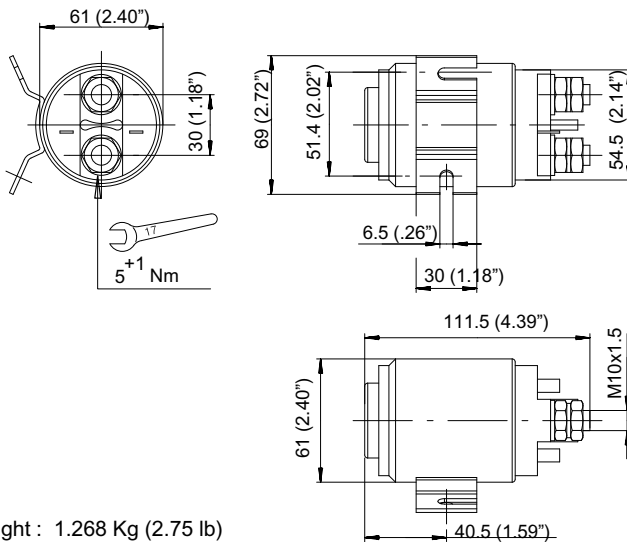

Weight : 1.268 Kg (2.75 lb)

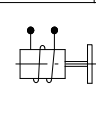
Voltage	24 V
Type	R212
Code	200544134212
Amps Consumption by the coil	1.1 A
Current for continuous duty	300 A
Protection index	IP42
Insulation class	B
Electric diagram	

5.2 A.C. Motors

5.2.1 Technical information

Versions:

Electric motors supplied by Bucher Hydraulics S.p.A. respond to European Standard EN60034-1 (IEC-3, CEI2-3, VDE 0530T1).

Available power ratings: 0.25 ÷ 4 kW
Single phase motor: 230V ±5% - 50 Hz
Three phase motor: 230/400V ±10% - 50 Hz

European standard IEC38 (1983) envisages the unification of supply voltages, adopting 230 V for single phase and 400 V for three phase. Motors responding to this standard are available only by request: consult our Bucher Hydraulics.

Protection factor

Standard electric motors are specified:
Protection degree: IP54 (IP55 on request)
Insulation class: F (max 105°).

Type of duty

All motors can be supplied rated for continuous duty S1 or intermittent duty S3<80%.

With respect to the European Standard IEC 60034-30:2008 all motors rated for continuous duty S1, will be manufactured according to IE2 Efficiency class

Efficiency class:

All motors respond to European standard IEC 60034-30:2008. This means all the motors between 0,75 kW and 375 kW both 2 and 4 poles, rated for continuous duty S1 or intermittent duty S3≥ 80%, are in IE2 Efficiency class.

Speed of rotation

The nominal speed of rotation for A.C. motors is calculated by the following formula: $n = (60 \cdot f) / P$
f= frequency (50 Hz for EU / 60 Hz for USA)

P= pair of poles

A 4 poles motor has 1500 rev/min as nominal speed

Pole number:

Indicated motors are 4 pole type, but Bucher Hydraulics S.p.A. can supply 2 pole motors too.
Please ask Bucher Hydraulics.

Size

The size designation gives the main dimensions for the standard electric motors: shaft dimensions, type of flange, max diameter, etc. A specific table shows the essential dimensions corresponding to each standard size.
The electric motors with direct flange have their own dimensions especially the front flange.

Frame size

Standard option:

Standard motors have B34 frame so mounting flange with spigot, tapped fixing holes and motor fixing feet.

B14 frame is also available on request (as B34 but without motor fixing feet).

Direct flange motors are delivered without fixing feet (B14 style).

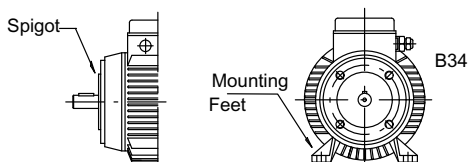

Ventilation:

All the motors (standard and direct flange) can be available with or without ventilation. Normally the direct flange motors are delivered without ventilation.

Important to say that motors without ventilation can not be rate for continuous duty S1.

Paint finish

All motors are aluminum alloy die cast not painted supplied, suitable for operation in an industrial environment.

Starting single phase motors

Standard single phase motors have a permanently connected run capacitor. Where starts are made on-load or in especially heavy-duty condition, requiring a starting torque higher than the nominal torque, single phase induction motors can be supplied, by request, with a dual capacitor arrangement: a start capacitor, disconnected by an automatic cutout once the motor is up to speed, and a permanently connected run capacitor, or hydraulic circuit with decompression valve assembled on the pump.

Please consult Bucher Hydraulics.

Electrical diagrams

The following illustration shows a number of connection diagrams for single phase and three phase electric motors.

The terminal boxes used for these motors respond to NFC 51-120 (IEC34-8) and have 6 power terminals.

A terminal is also provided for the earth wire, which must always be connected

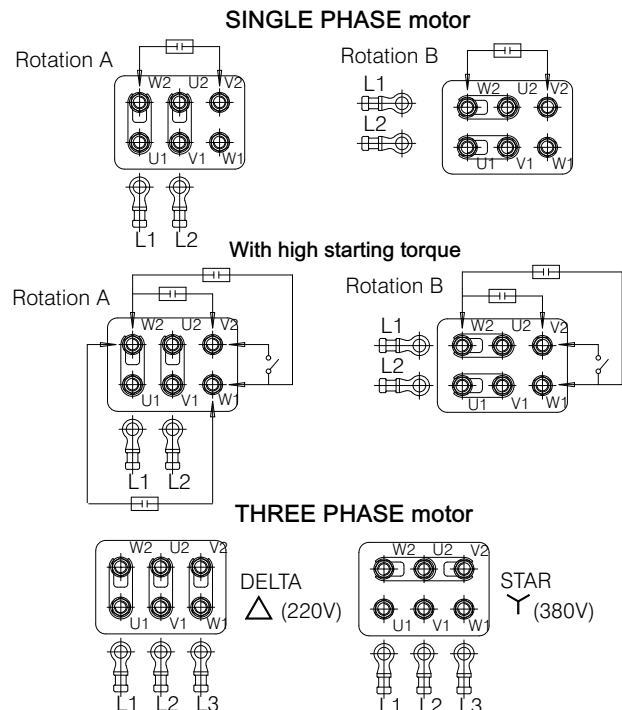

Three phase motors: with terminals U1-V1-W1 connected respectively to phases L1-L2-L3 of supply, the motor will rotate clockwise (as viewed from the shaft end).

Bucher Hydraulics S.p.A. is not an electric motors manufacturer so these components come from third part. Bucher Hydraulics S.p.A. reserves the right to change the motor supplier whenever considers it necessary without notice.

5.2.2 Standard interface (flange/drive needed)

Frame size

B34

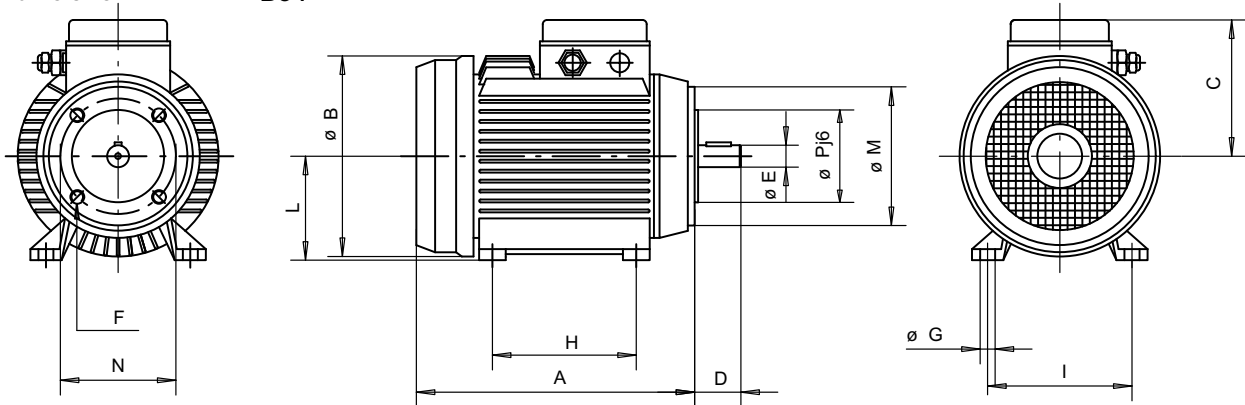

Size	Units	Dimensions												
		A	B	C	D	E	F	G	H	I	L	M	N	P
71	mm	218	140	109	30	14	M6	7	90	112	71	105	85	70
	inch	8.58	5.51	4.29	1.18	0.55		0.27	3.54	4.41	2.79	4.13	3.35	2.76
80	mm	237	156	123	40	19	M6	9	100	125	80	120	100	80
	inch	9.33	6.14	4.84	1.57	0.75		0.35	3.94	4.92	3.15	4.72	3.94	3.15
90S	mm	255	178	128	50	24	M8	9	100	140	90	140	115	95
	inch	10.04	7	5.04	1.97	0.94		0.35	3.94	5.51	3.54	5.51	4.53	3.74
90L	mm	279	178	128	50	24	M8	9	125	140	90	140	115	95
	inch	11	7	5.04	1.97	0.94		0.35	4.92	5.51	3.54	5.51	4.53	3.74
100	mm	309	194	137	60	28	M8	12	140	160	100	160	130	110
	inch	12.16	7.64	5.40	2.36	1.1		0.47	5.51	6.3	3.94	6.3	5.12	4.33
112	mm	331	219	50	60	28	M8	12	140	190	112	160	130	110
	inch	13.03	8.62	1.97	2.36	1.1		0.47	5.51	7.48	4.41	6.3	5.12	4.33

Note: Indicated dimensions can vary without notice within the maximum admitted by the European Standards IEC72-1 and IEC34-7.

5.2.3 Direct flange (simple drive needed)

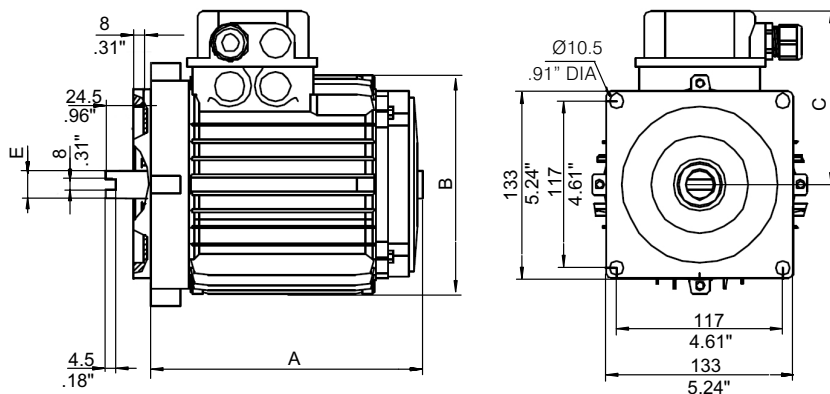

Size	Units	Dimensions			
		A	B	C	E
71	mm	183	136	122	17
	inch	7.20"	5.35"	4.80"	.67"
80	mm	198	154	143	17
	inch	7.80"	6.06"	5.63"	.67"
90S	mm	213	174	148	25
	inch	8.39"	6.85"	5.82"	.98"
90L	mm	237	174	148	25
	inch	9.33"	6.85"	5.82"	.98"

5.2.4 Standard interface 4 pole - 50 Hz - 230 V

Frame size B14 SINGLE PHASE				
Power		Size	Type	Code
kW	HP			
0.25	0.33	71	T209	200543161221
0.37	0.5	71	T201	200543161823
0.55	0.75	80	T202	200543162231
0.75	1	80	T203	200543162631
1.1	1.5	90S	T204	200543163041
1.5	2	90L	T205	200543163441
2.2	3	100	T206	200543164051

Frame size B34 SINGLE PHASE				
Power		Size	Type	Code
kW	HP			
0.25	0.33	71	T709	200543161223
0.37	0.5	71	T701	200543161822
0.55	0.75	80	T702	200543162233
0.75	1	80	T703	200543162633
1.1	1.5	90S	T704	200543163042
1.5	2	90L	T705	200543163442
2.2	3	100	T706	200543164052

5.2.5 Standard interface 4 pole - 50 Hz - S1 - 230/400 V

Frame size B14 THREE PHASE					
	Power		Size	Type	Code
	kW	HP			
IE2 efficiency class	0.25	0.33	71	T009	200543561221
	0.37	0.5	71	T001	200543561821
	0.55	0.75	80	T002	200543562231
	0.75	1	80	T003	200543562635
	1.1	1.5	90S	T004	200543563047
	1.5	2	90L	T005	200543563451
	2.2	3	100	T006	200543564058
	3	4	100	T007	200543564854
	4	5.5	112	T008	200543565065

Frame size B34 THREE PHASE					
	Power		Size	Type	Code
	kW	HP			
IE2 efficiency class	0.25	0.33	71	T509	200543561222
	0.37	0.5	71	T501	200543561822
	0.55	0.75	80	T502	200543562232
	0.75	1	80	T503	200543562634
	1.1	1.5	90S	T504	200543563046
	1.5	2	90L	T505	200543563450
	2.2	3	100	T506	200543564057
	3	4	100	T507	200543564853
	4	5.5	112	T508	200543565064

5.2.6 Standard interface 4 pole - 50 Hz - S3=70% - 230/400 V

Frame size B14 THREE PHASE				
Power		Size	Type	Code
kW	HP			
0.75	1	80	T003	200543562631
1.1	1.5	90S	T004	200543563041
1.5	2	90L	T005	200543563441
2.2	3	100	T006	200543564051
3	4	100	T007	200543564851
4	5.5	100	T008	200543565061

Frame size B34 THREE PHASE				
Power		Size	Type	Code
kW	HP			
0.75	1	80	T503	200543562632
1.1	1.5	90S	T504	200543563042
1.5	2	90L	T505	200543563442
2.2	3	100	T506	200543564052
3	4	100	T507	200543564852
4	5.5	100	T508	200543565062

5.2.7 Direct flange 4 pole -50 Hz - S3=30% - 230 V

Frame size B14 style SINGLE PHASE				
Power		Size	Type	Code
kW	HP			
1.5	2	90*	TC05	200543163443
2.2	3	90*	TC06	200543164054

5.2.8 Direct flange 4 pole -50 Hz - S3=30% - 230/400

Frame size B14 style THREE PHASE				
Power		Size	Type	Code
kW	HP			
1.5	2	80*	TA05	200543563452
2.2	3	90*	TA06	200543564059

* As reference only: special sizes not included in the European Standards IEC72-1 and IEC34-7

Mounting position

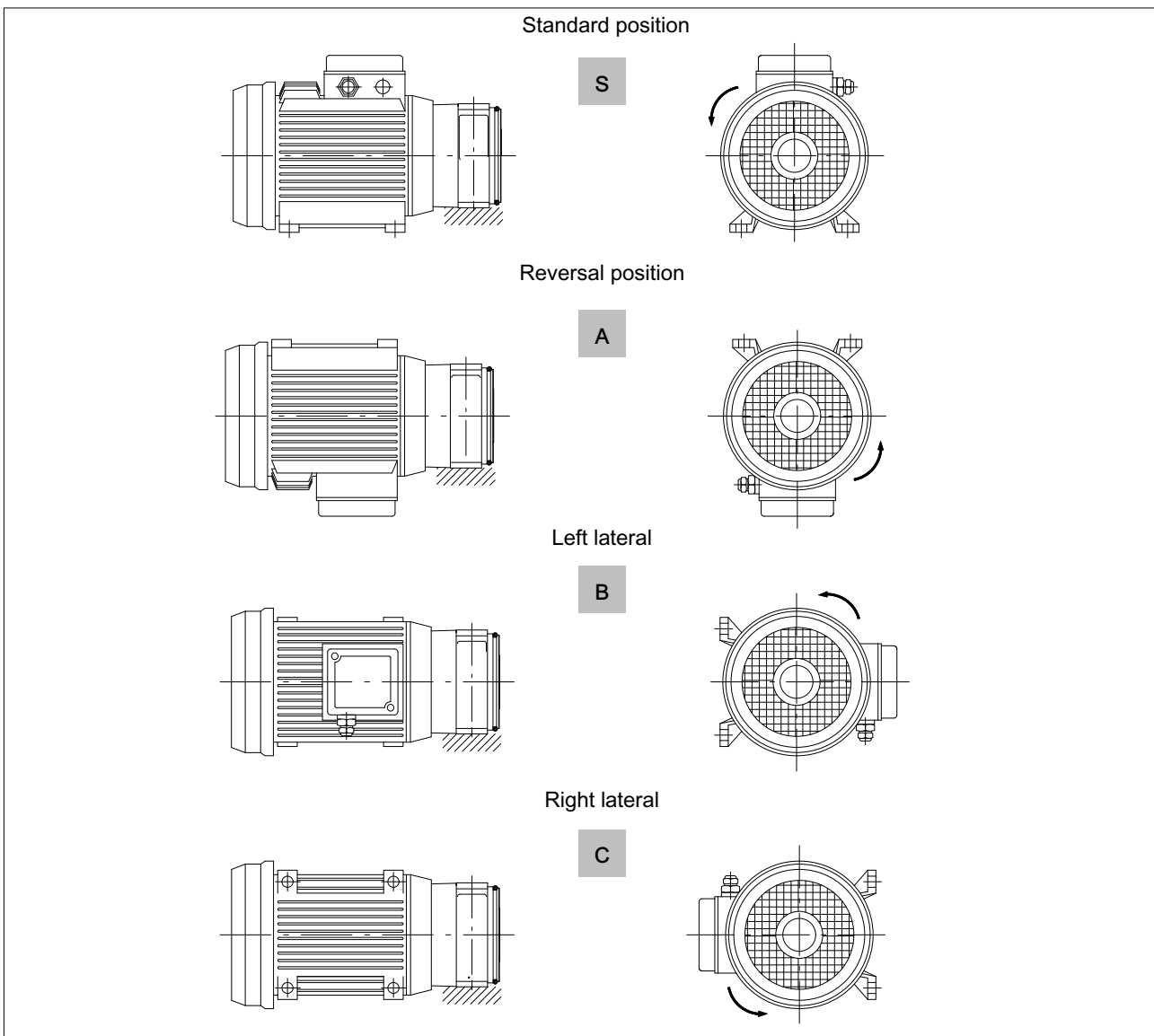

Example	Electric motor	Pos
5	T 5 0 3	S

Relay	Pos

N.B.: Looking at the fan side the e. motor must rotate counterclockwise

6 Drives

6.1 Introduction

The drives illustrated in this chapter are intended for use in conjunction with D.C. and A.C. motors as described in the previous chapter.

To allow the use of different motors, the interface on the motor side is shown with the dimensions of the spigot and of the end of the pump drive shaft.

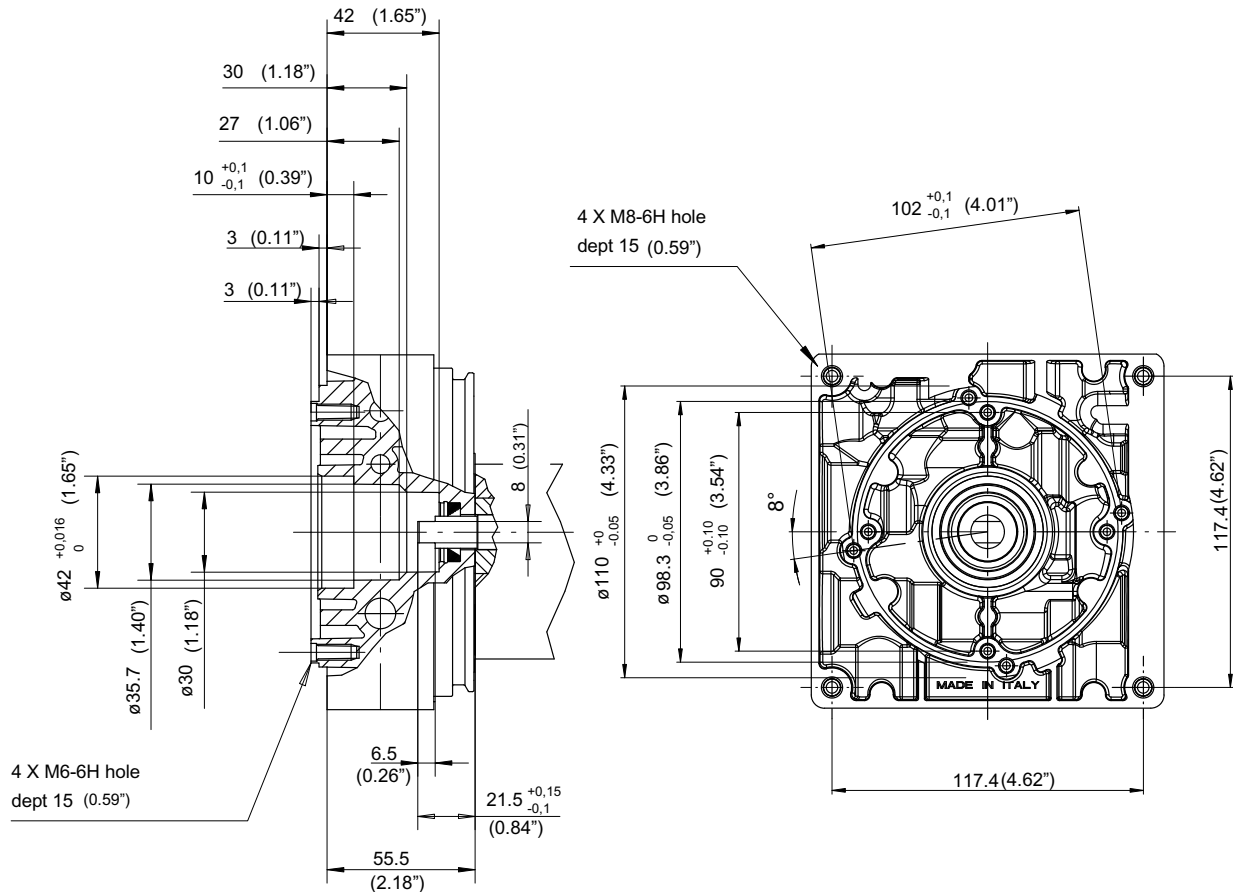

6.1.1 Materials

The flanges for connection of the power pack housing and electric motor are in aluminium alloy GdAlSi12Cu to EN-AB 46100 (UNI5076).

Couplings are high strength steel, with mating surfaces hardened by heat treatment for added resistance to wear.

6.2 Drives for D.C. motors

The tables allow selection of the correct drive for the selected motor.

Motor type		Voltage	Power	Drive
C135AB/H0	C135AB/H0 + R109	12 V	1600 W	E145
C240AB/S0	C240AB/S0 + R215	24 V	2200 W	
T107E	T107E + R109	12 V	1700 W	
T109E	T109E + R215	24 V	2200 W	
C248AK/Z0	C248AK/Z1	24 V	3000 W	
C134AK/O0	C134AK/O0 + R109	12 V	1500W	E156
C238AK/P0	C238AK/P0 + R215	24 V	2000 W	
T82K		48 V	2000 W	
T106K		24 V	3000 W	
C128PK/A0	C128PK/A0 + R109	12 V	800 W	E163
C228PK/A0	C228PK/A0 + R215	24 V	800 W	

6.3 Drives for A.C. motors

6.3.1 Single phase

Motor type	Power		Size	Drive
	kW	HP		
T209-T709	0.25	0.33	71	E133
T201-T701	0.37	0.5		
T202-T702	0.55	0.75	80	E131
T203-T703	0.75	1		
T204-T704	1.1	1.5	90S	E132
T205-T705	1.5	2	90L	
T206-T706	2.2	3	100	E137

6.3.2 Three phase

Motor type	Power		Size	Drive
	kW	HP		
T009-T509	0.25	0.33	71	E133
T001-T501	0.37	0.5		
T002-T502	0.55	0.75	80	E131
T003-T503	0.75	1		
T004-T504	1.1	1.5	90S	E132
T005-T505	1.5	2	90L	
T006-T506	2.2	3	100	E137
T007-T507	3	4		
T008-T508	4	5.5	112	

6.3.3 Direct flange

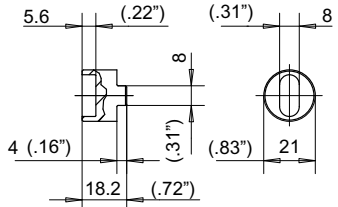
Motor type	Power		Size	Drive code
	kW	HP		
TA05	1.5	2	80	
TC05			90*	
TC06 - TA06	2.2	3	90*	

6.4 Drive E145

Code E145 200960400400

Bush code
200658200061

Coupling code
200659600290

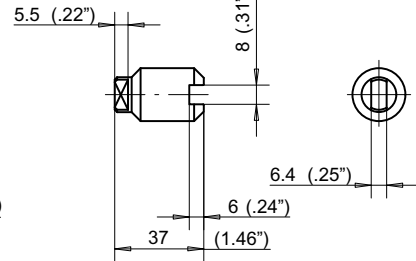
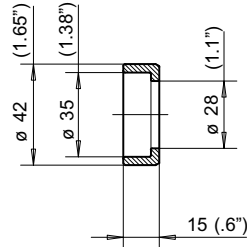
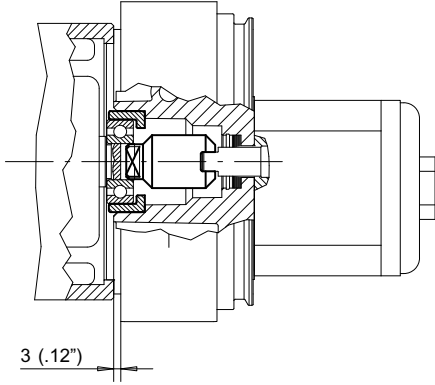

6.5 Drive E156

Code E156 200659600280

Coupling code
200659600280

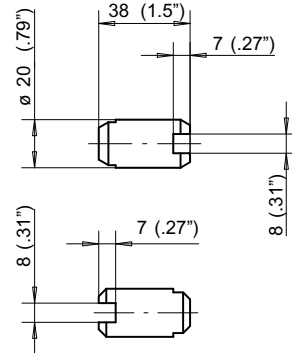
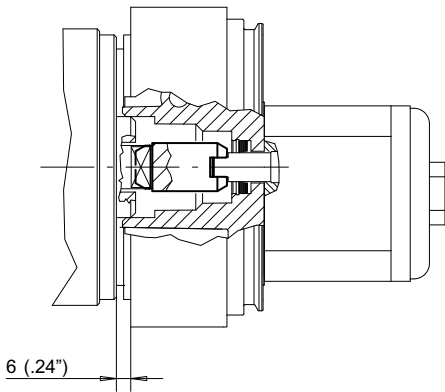

6.6 Drive E163

Code E163 200960400410

Coupling code
200659600290

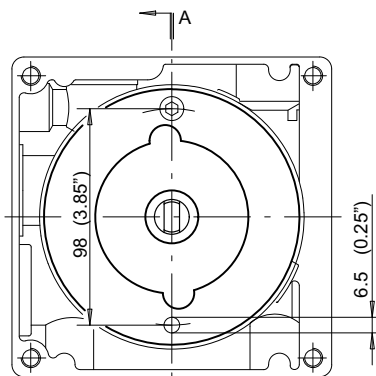
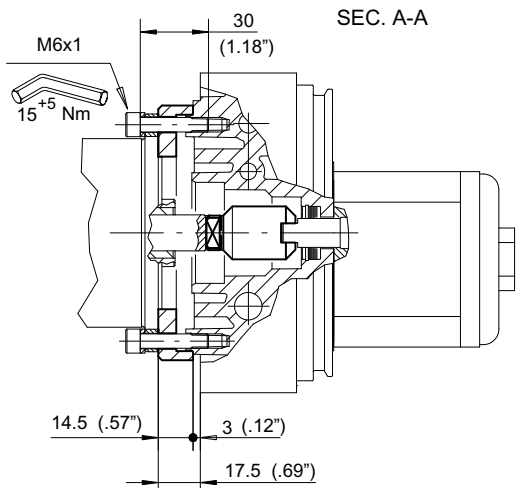

Flange code
200658200210

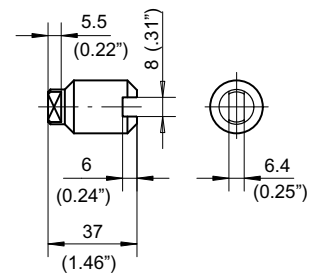

6.7 Drive E131

Code E131 200960400430

Flange code
200658200110

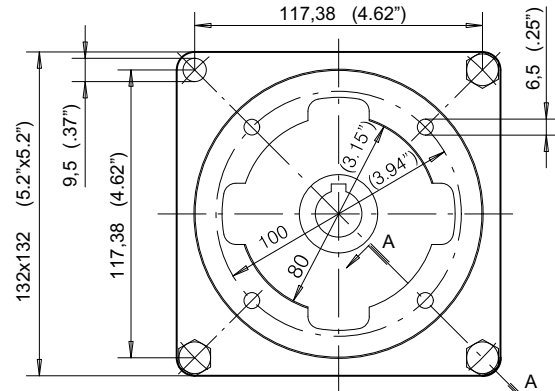
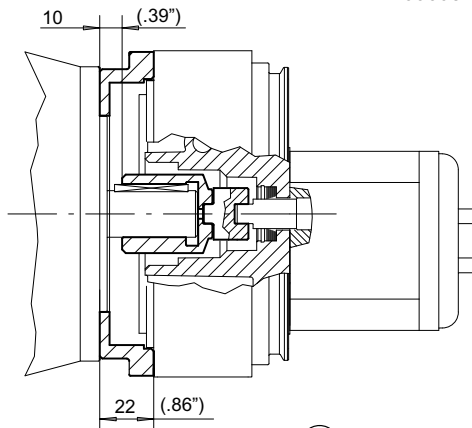

Fixing system
Kit code: 200771900340

(A) Motor coupling 200659400190

(B) Pump coupling: 200659400330

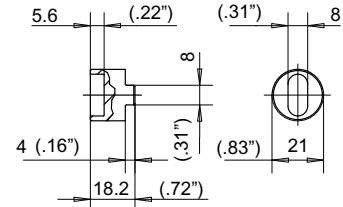
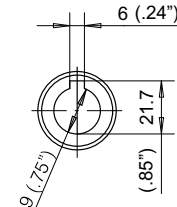
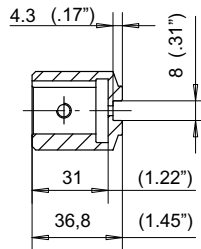
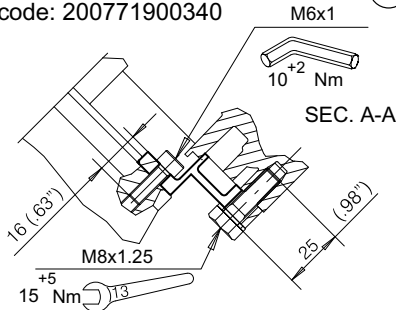

(A) + (B) Code: 200959400120

6.8 Drive E132

Code E132 200960400440

Flange code
200658200130

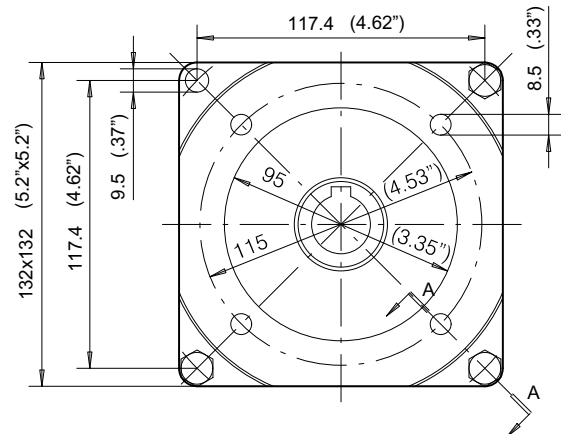
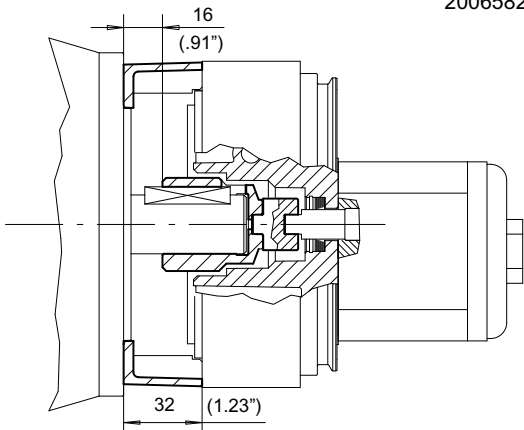

Fixing system
Kit code: 200771900350

(A) Motor coupling: 200659400230

(B) Pump coupling: 200659400330

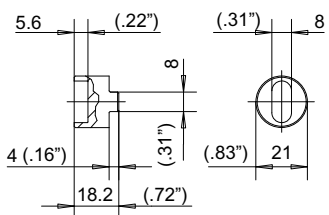
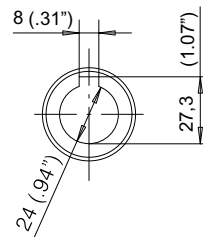
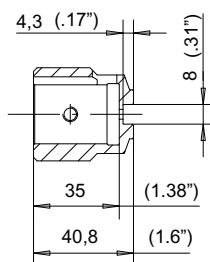
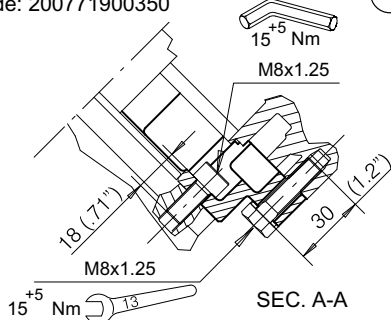

(A) + (B) Code: 200959400130

6.9 Drive E133

Code E133 200960400420

Flange code
200658200120

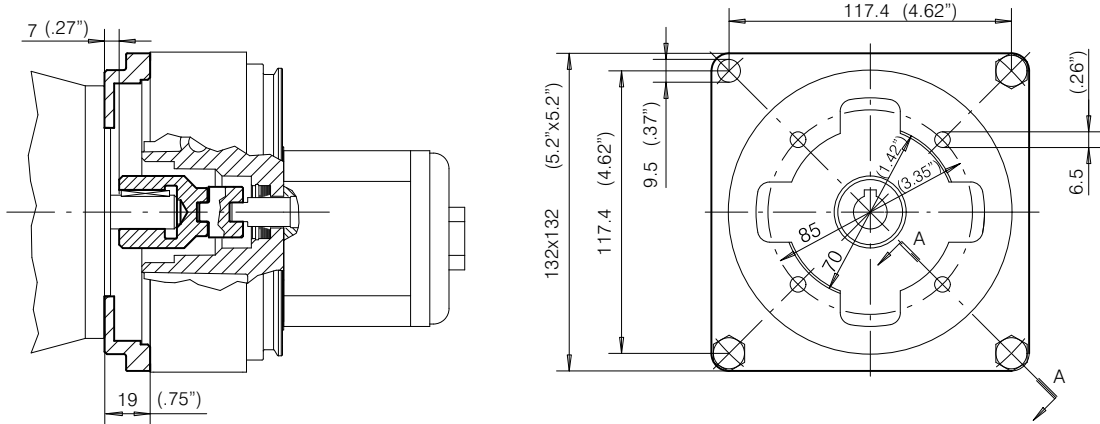

Fixing system
Kit code: 200771900361

(A) Motor coupling 200659400220

(B) Pump coupling 200659400330

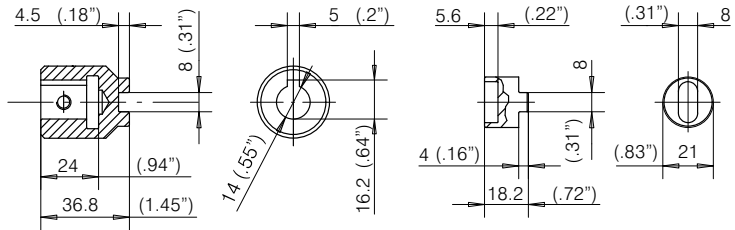
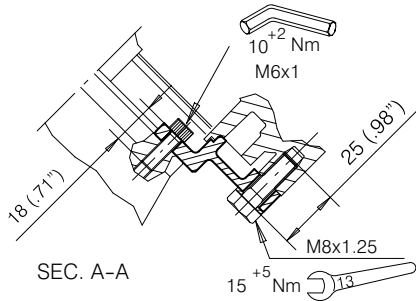

(A) + (B) Code: 200959400110

6.10 Drive E137

Code E137 200960400450

Flange code
200658200140

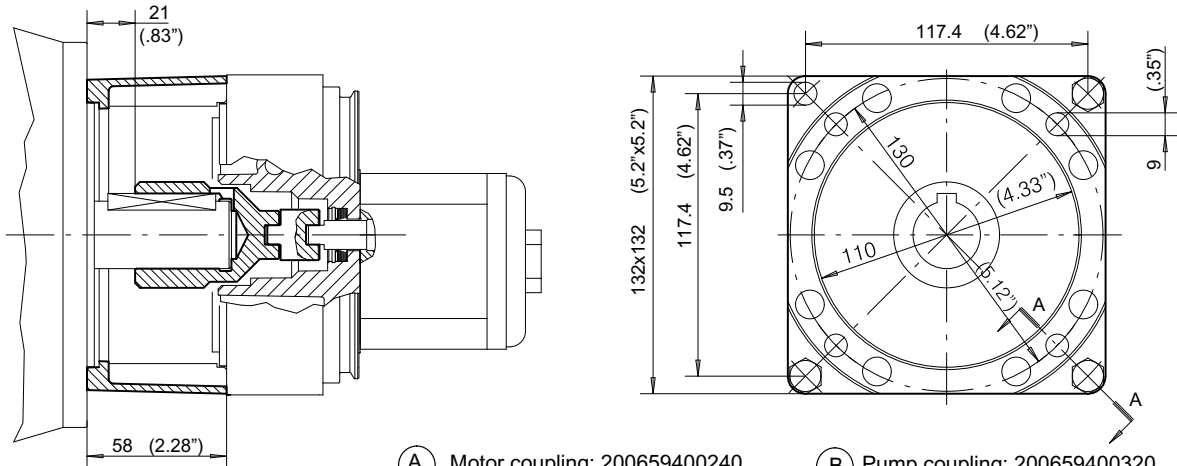

Fixing system
Kit code: 200771900370

(A) Motor coupling: 200659400240

(B) Pump coupling: 200659400320

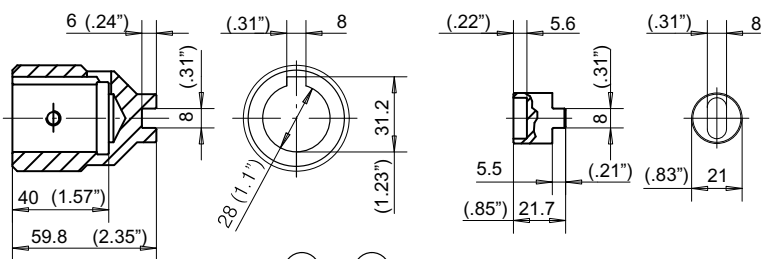
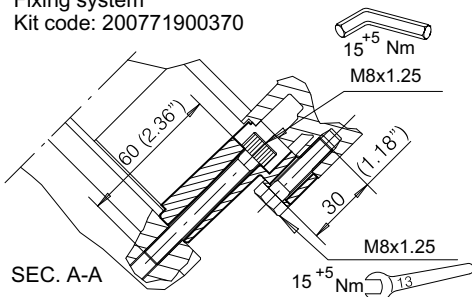

(A) + (B) Code: 200959400140

6.11 Drive E181

- The E181 Drive is mostly used in application where radial or axial forces occur like: Pulley drive, gear drive, etc.
- The E181 drive can be used with any type of UP100K housing rotation counterclockwise.

Code E181 200760400470

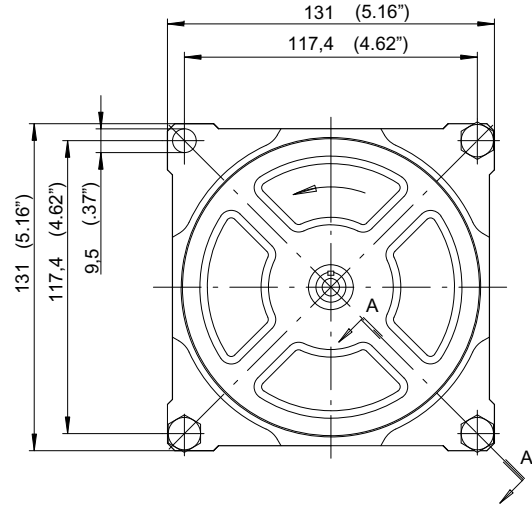
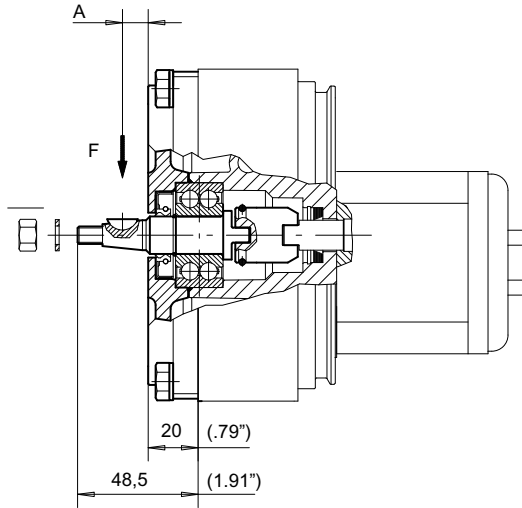

Shaft end

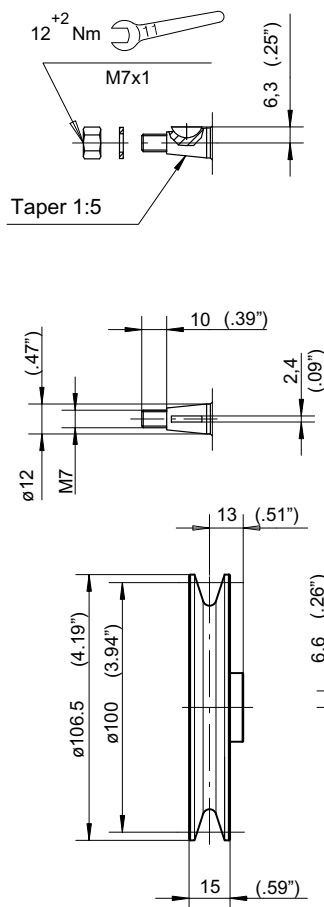

Fixing system

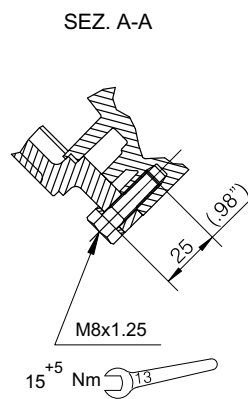

Bearing life

Lh=1000 (h)

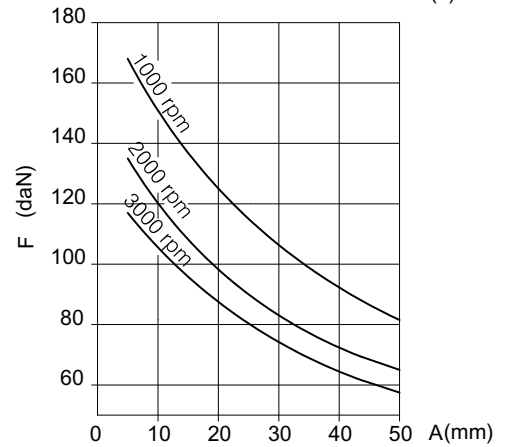

Drive E181 does not include the Ø100 pulley, which must be ordered separately

Ø100 pulley, part number: 200669000010

7 Cartridge valves

7.1 Introduction

This chapter includes all technical information relating to valves for use in conjunction with the housings described in section 1.

Complete the designation codes for the selected valves

according to the technical information and guidelines given for each component. Illustrated here by way of example is a correct and complete compilation for section 7 of the hydraulic power pack designation form.

7	Cavity a	Cavity b	Cavity c
	1 5 V M 0 1 C	R S 3 / 8 1 7	S D F 8 1 7 / 2 2 - T H
	Cavity d	Cavity e	Cavity f
	N V 1 / 8 1 7 - R	V R C 8 1 8 / 1 1 - F	
	Cavity g	Hand lever	Stick lever
			Volt
			2 3

7.1.1 Materials

Bucher Hydraulics cartridge valves are manufactured using steel of high mechanical strength. Friction and potential wear are minimized by special heat treatments. Surface heat treatments protect parts exposed to the external environment. Standard seals are NBR (Buna N), with backup ring in PTFE. For application requiring special compound FPM (Viton) etc. consult Bucher Hydraulics.

7.1.2 Indication for use

Use mineral oil based hydraulic fluids to ISO/DIN standard, only. Recommended viscosity range: 20-120 mm²/s (cSt) maximum viscosity 700 mm²/s (cSt).

For different fluids and operating conditions, consult our Sales Dpt.

All valves showed in the present catalogue are marked with correct flow direction, please observe it always. Valves must never be tampered with or modified.

Any unwarranted interference may adversely affect the safety and correct operation of the entire system.

Seals and backup rings are user-serviceable.

The appropriate replacement kit is indicated for each valve.

Before installing a valve in its cavity, ensure that the housing and all components of the system are clean.

Smear external seals lightly with grease, and check that any filters installed are correctly positioned.

Tighten the valve to the specified torque setting.

7.1.3 General technical information

All valves with leakage-free operating characteristic are 100% factory tested.

Nonetheless, the guaranteed maximum leakage may be exceeded if the valve is installed in a system with inadequate filtration.

Pressure drops and general performance indicated in the catalogue are referred exclusively to the component.

In the case of valves subject to adjustable setting, such as the pressure relief and if not specified in the order, we set them according to standard setting values indicated at section 7.2.1.

7.1.4 Solenoid valves

The correct selection of the solenoid valve is related to the maximum flow rate and operating pressure values. In a system with a single acting cylinder, therefore, it must be considered that the effective rate of flow through the unloading solenoid valve is not the flow delivered by the pump, but rather the momentary flow exhausted from the cylinder, or the restricted flow needing a pressure-compensated flow control valve, if installed.

The nominal voltage is the value indicated on the solenoid.

Effective voltage must be measured at the terminals of the solenoid connector.

A maximum allowed tolerance of ±10% in relation to the nominal value is accepted.

Incorrectly power supply components and cables (which length has to be as shorter as possible) and/or low battery charge can cause not correct solenoid valve operation.

Standard solenoids valves are designed for D.C. operation. A.C. supply requires a connector with bridge rectifier included. When energized with A.C. voltage, the solenoids can operate at 50 or 60 Hz frequency, without distinction.

The connection used for standard solenoids are to EN 175301-803 (DIN 43650).

Solenoid with different connections (Amp JuniorTimer, Direct Wiring, etc.) can be supplied on request, after agreement with Bucher Hydraulics.

The solenoid can be rotated through 360°, and the connector EN 175301-803 (DIN 43650) positioned at 90° intervals.

Specified performance datas were recorded in stabilized solenoid operated temperature and voltage at the -10% of the nominal value.

All solenoid valves are fitted with protective O-rings installed between the tube and the solenoid.

This protects internal parts from condensation and contaminants, which could cause malfunction.

Standard solenoids are not suitable for operation in environments where there is any risk of explosion (see Directives and standards)

7.1.5 General notes on D.C. power input

A swift and secure coupling is obtained using the special connector (type 200544110009).

The cable coming from the D.C. power source (batteries, rectified a.c. main supply, etc.) must be connected as indicated in the diagram (figure 1).

The negative and positive polarity of the wire need not be verified for connection purposes. The connector incorporates a terminal for earthing the solenoid.

It is important to check that the grommet and armour clamp nut are correctly assembled (figure 2), as this prevents the cable being wrenched from connector.

7.1.6 General notes on A.C. power input

Solenoid valves can be operated off the A.C. mains supply using a special connector (type 200544110012) which converts the current to provide the D.C. input required by the solenoid.

The connector in question is identified by a symbol (figure 3) marked both on the top and on the bottom face.

The conversion from alternate to direct current is effected by a rectifier circuit comprising a four-diode bridge, and a voltage-dependent resistor (figure 4) protecting against over voltages in the power supply circuit.

Accordingly, the solenoid are designed to operate correctly only when connected to a diode bridge which reduces the input voltage by 10%.

The earth connection is made by way of the terminal provided.

Fig. 1

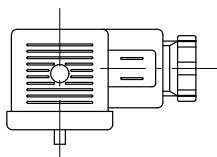

Fig. 3

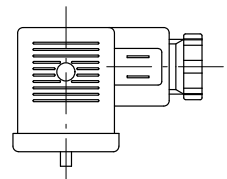
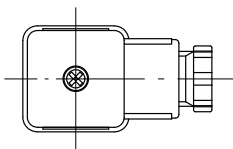

Fig. 2



Rectifier symbol

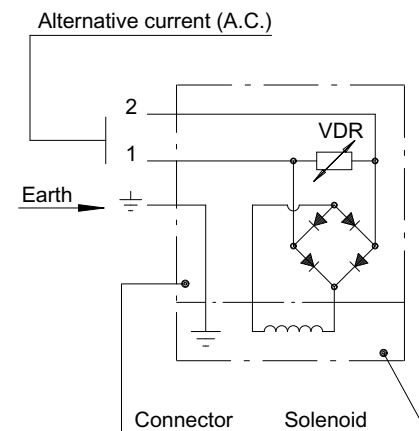
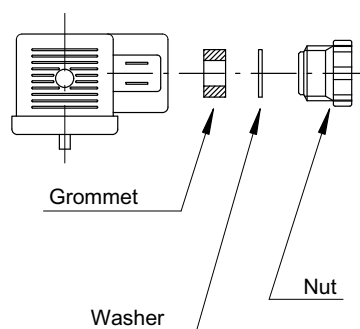
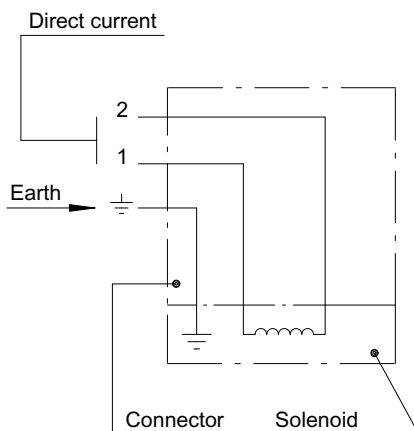
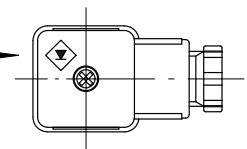
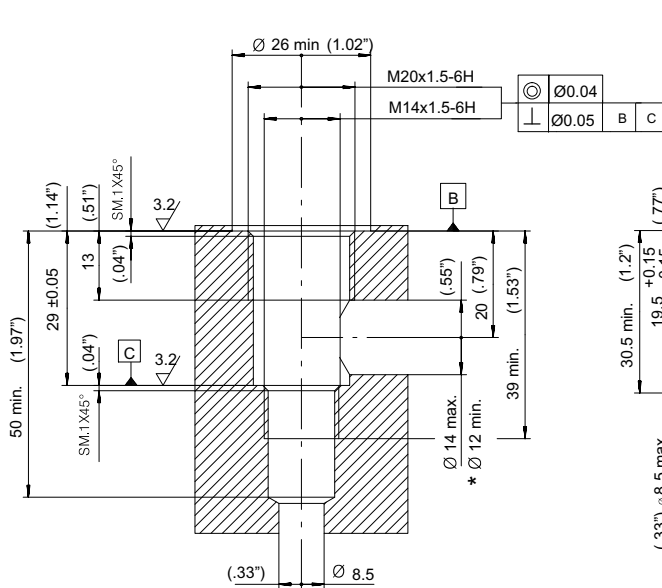

Fig. 4

For users wishing to make up special circuits and blocks with Bucher Hydraulics S.p.A. cartridge valves, it is important to

observe the indications given below when machining the valve cavities.

Two-way cavity M20x1.5



Two-way cavity 3/4" - 16 UNF

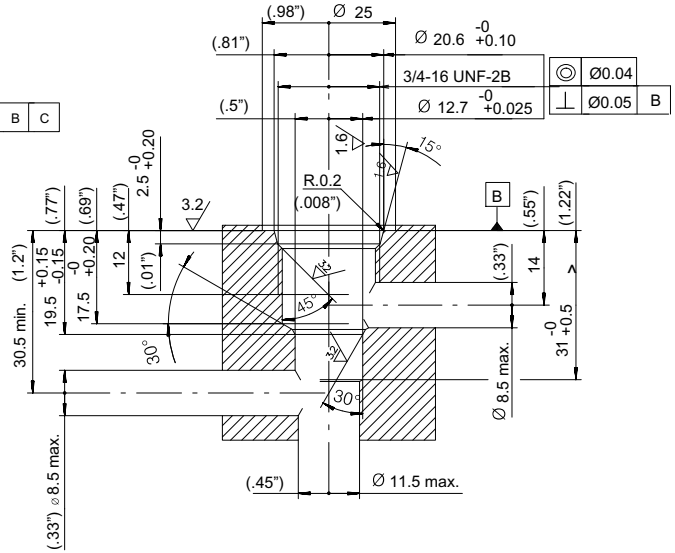

* If not possible to comply with the minimum diameter (12 mm), consider to increase the internal diameter (18,5 mm) with anular area near the discharging hole.

Two-way cavity 7/8" - 14 UNF

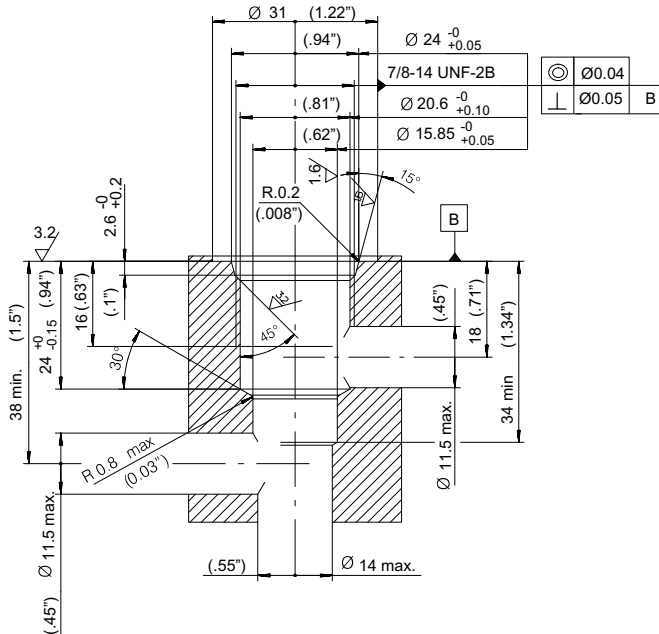

7.2 Pressure relief valves

7.2.1 Pressure relief valve: **VM01C

Direct acting
Balanced piston
Adjustable setting
Four setting ranges

Max. pressure. 350 bar ***
Max flow rate 60 l/min.
Temperature range -20/+100 °C
Weight 0.155 Kg.

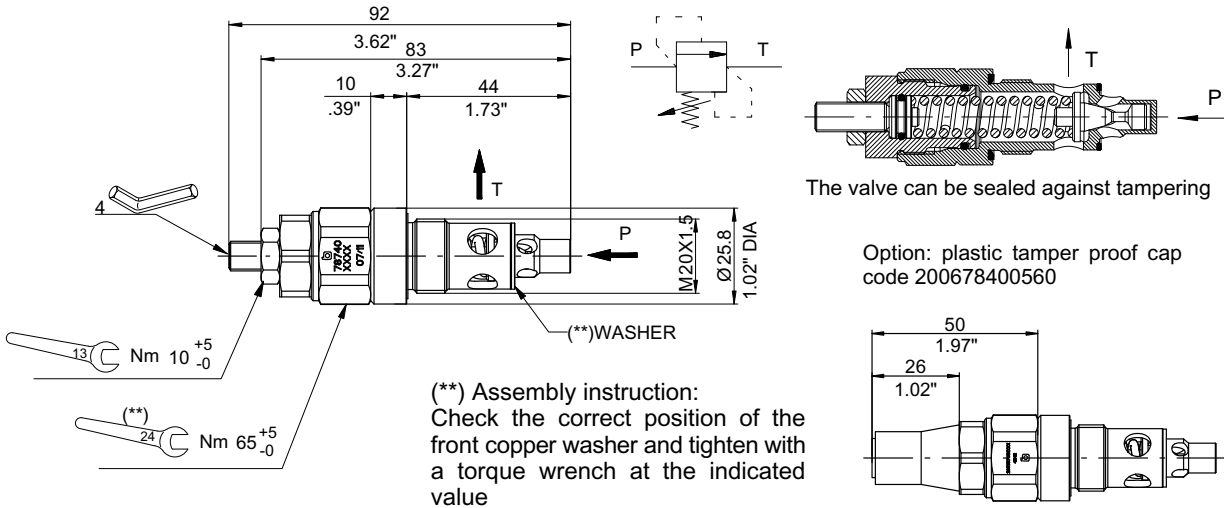

Pressure viscosity characteristic 46 cSt at 40°C

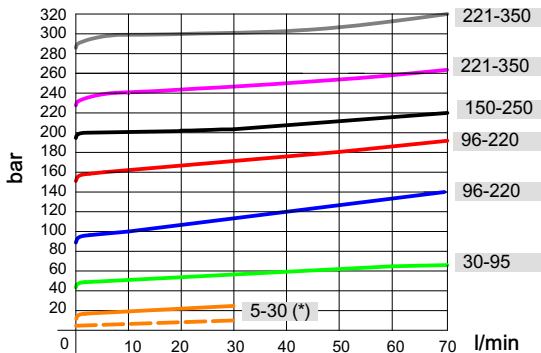

(*) see performances trace/minimum pressure setting (---)

The purpose of a relief valve is to keep the maximum system pressure at a safe level. When the hydraulic power unit is supplied with pressure relief valves, the correct calibration is provided by Bucher Hydraulics S.p.A. and there are no reasons to change this value. When ordering, state in full the sheath part number, and, if the valve is to be supplied with sheath already fitted, the relief pressure setting required.

*** Maximum admitted pressure value: 230 bar when used into the diecast aluminium alloy body

Pressure setting

For present values other than those indicated, replace the first two digits of the designation with the setting required. For example, required setting 120 bar: designation type 12 VM01C. Always check that the required value falls within the standard ranges of adjustment.

Performances	
Max. flow	60 l/min.
Pressure setting flow	5 l/min
Max internal leakage	200 cm ³ /min at 80% of nominal pressure setting
Oil viscosity	12 to 400 cSt
Oil temperature	-20 to 100 °C
Recommended filtration	21/19/16 (10 NAS 1638)
Marking info:	Printed code and date

Spring	Spring code	Setting range	Standard setting	Q max (l/min)	Type	Code
00	-	Plugged	Without valve	-	00VC00	200978400140
02	200662403160	5 - 30 bar	20 bar	30 (*)	02VM01C	200787403600
05	200662403080	30 - 95 bar	50 bar	60	05VM01C	200787403480
12	200662403050	96 - 220 bar	120 bar	60	12VM01C	200787403420
15	200662403070	150 - 250 bar	150 bar	60	15VM01C	200787403470
23	200662403060	221 - 350 bar	230 bar	60	23VM01C	200787403430

7.3 Check valves

7.3.1 Check valve: RS3/817

Ball type

Flow from 2 to 1

Code 200787601410

Max. pressure 230 bar
 Max. flow 25 l/min.
 Cracking pressure 0.5 bar
 Temperature range -20/+90 °C
 O-Ring replacement kit 200974200160
 Weight 0.040 Kg.

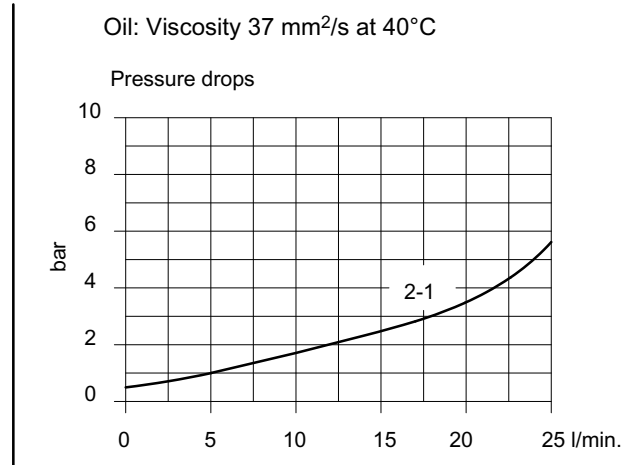
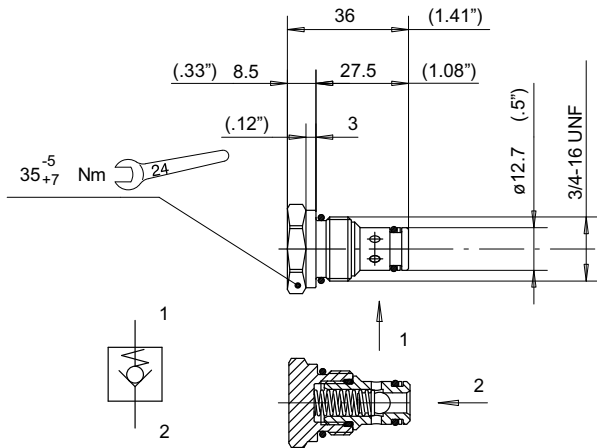

7.3.2 Check valve: RM3/817-A

Ball type

Flow from 2 to 1

Pressure through 1 and M

Code 200787602160

Max. pressure 230 bar
 Max. flow 25 l/min.
 Cracking pressure 0.5 bar
 Temperature range -20/+90 °C
 O-Ring replacement kit 200974200160
 Weight 0.070 Kg.

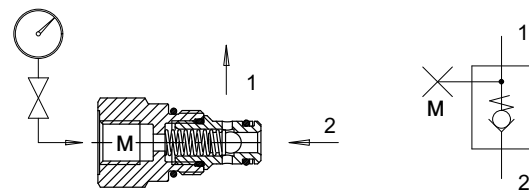
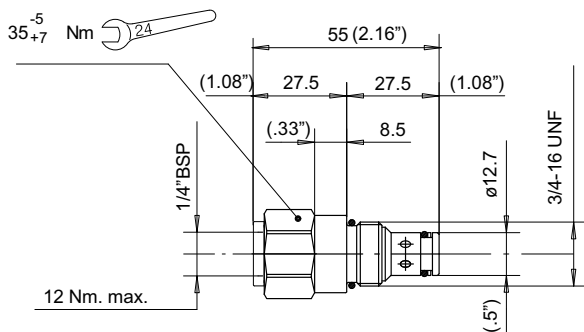

Port M must be used only as a pressure outlet.
 Normally supplied plugged.

Apply the prescribed tightening torque at port **M**.
 Pressure drops: see RS3/817 performances

7.4 Solenoid operated directional valves

Circuit	Solenoid	Override	Type	Power	Description	Page		
Normally closed	On-Off	Without manual override	Direct acting	heavy duty (27 Watt)	SDF817/22-TH	Page 102		
				heavy duty (27 Watt)	SDR817/22-TV	Page 103		
			Piloted	standard (18 Watt)	SPD817/22-TV	Page 104		
			With manual override	Direct acting	heavy duty (27 Watt)	SDRE817/22-TV	Page 102	
					Piloted	standard (18 Watt)	SPE817/22-TV	Page 105
				Proportional	With manual override	Piloted	standard (20-26 Watt)	PDF817/HSC
		Normally open				On-Off	With manual override	Piloted

7.4.1 Solenoid operated directional valve:
SDF817/22-TH

Normally closed
Direct acting - 27 Watt

Poppet type
Flow from 1 to 2

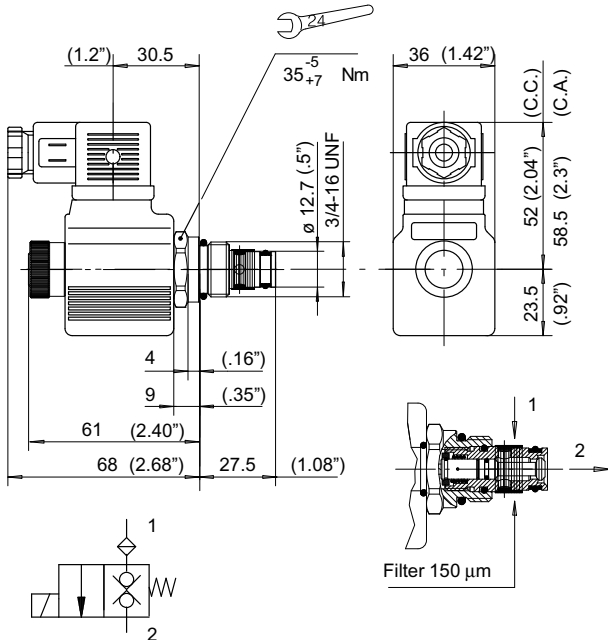

Weight (complete valve): 0.350 Kg.

Electric performances	
Max. pressure	230 bar
Max recommended pressure	210 bar
Max. flow	8 l/min. 210 bar
Rated power	27 Watt
Intermittence	ED= 100%
Voltage tolerance	± 10%
Internal leakage	0-5 drops/min.
Temperature range	-20/+90 °C
Connector type	DIN 43650
Time to open (50-210 bar)	15-50 ms.
Time to close (50-210 bar)	10-50 ms.
O-Ring replacement kit	20059999614

Oil: Viscosity 37 mm²/s at 40°C

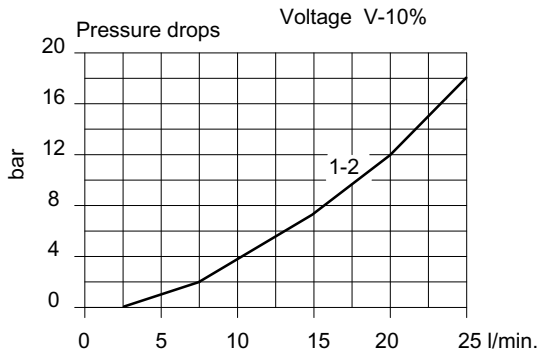

Max. flow rate depending on nominal pressure

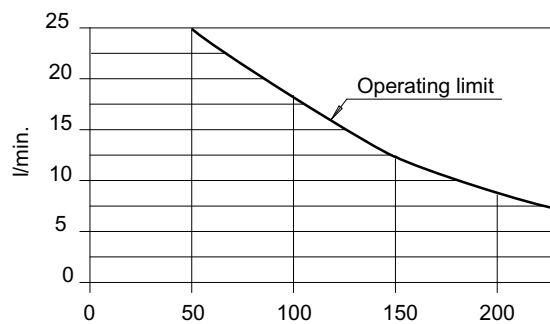

Directional valve without coil and connector

SDF817/22-TH P.M.	200757200900
-------------------	--------------

Complete solenoid valve for D.C. current

SDF817/22-TH-13-HC27	200957010061
SDF817/22-TH-23-HC27	200957020067

Coil voltage - A.C. supply requires a connector with bridge rectifier included.

27 Watt	D.C.		A.C.		
Volt	12 V.	24 V.	24 V.	110 V.	220 V.
Type	13	23	21	41	51

Complete solenoid valve for A.C. current

SDF817/22-TH-21-HC27	200956920048
SDF817/22-TH-41-HC27	200956940043
SDF817/22-TH-51-HC27	200956960049

7.4.2 Solenoid operated directional valve: SDR(E)817/22-TV

Normally closed
With or without manual override
Direct acting - 27 Watt

Poppet type
Flow from 1 to 2

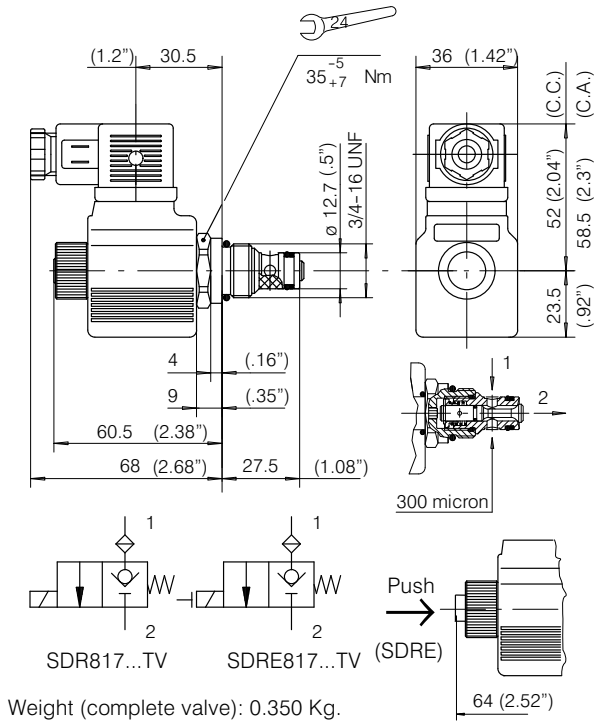

Electric performances	
Max. pressure	230 bar
Max recommended pressure	210 bar
Max. flow	20 l/min. 210 bar
Rated power	27 Watt
Intermittence	ED= 100%
Voltage tolerance	± 10%
Internal leakage	0-5 drops/min.
Temperature range	-20/+90 °C
Connector type	DIN 43650
Time to open (50-210 bar)	15-50 ms.
Time to close (50-210 bar)	15-50 ms.
O-Ring replacement kit	200974200390

Oil: Viscosity 37 mm²/s at 40 °C

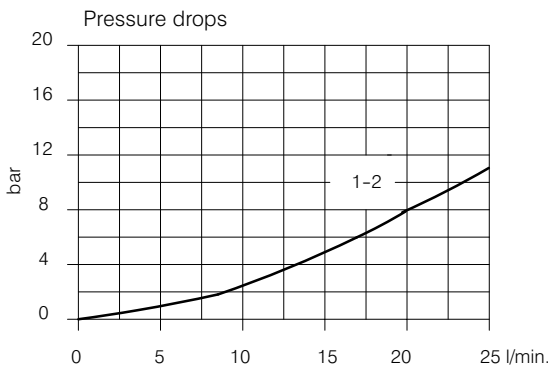

Max. flow rate depending on nominal pressure

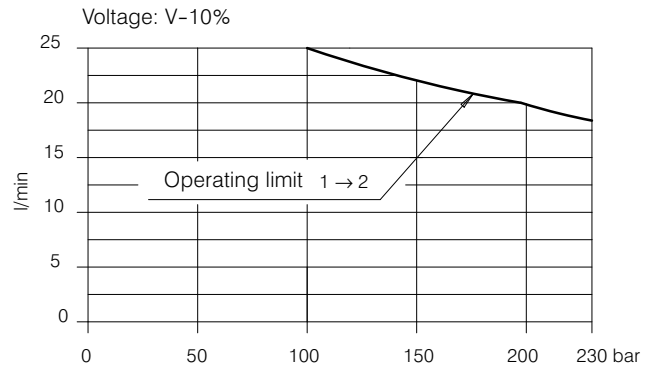

Directional valve without coil and connector

SDR817/22-TV P.M.	200757200840
SDRE817/22-TV P.M.	200757200820

Complete solenoid valve for D.C. current

SDR817/22-TV-13-HC27	200957010058
SDR817/22-TV-23-HC27	200957020060
SDRE817/22-TV-13-HC27	200957010057
SDRE817/22-TV-23-HC27	200957020059

Coil voltage - A.C. supply requires a connector with bridge rectifier included.

27 Watt	D.C.		A.C.		
	12 V.	24 V.	24 V.	110 V.	220 V.
Type	13	23	21	41	51

Complete solenoid valve for A.C. current

SDR817/22-TV-21-HC27	200956920046
SDR817/22-TV-41-HC27	200956940040
SDR817/22-TV-51-HC27	200956960043
SDRE817/22-TV-21-HC27	200956920045
SDRE817/22-TV-41-HC27	200956940039
SDRE817/22-TV-51-HC27	200956960042

**7.4.3 Solenoid operated directional valve:
SPD817/22-TV**

Normally closed Poppet type
Pilot type Flow from 1 to 2

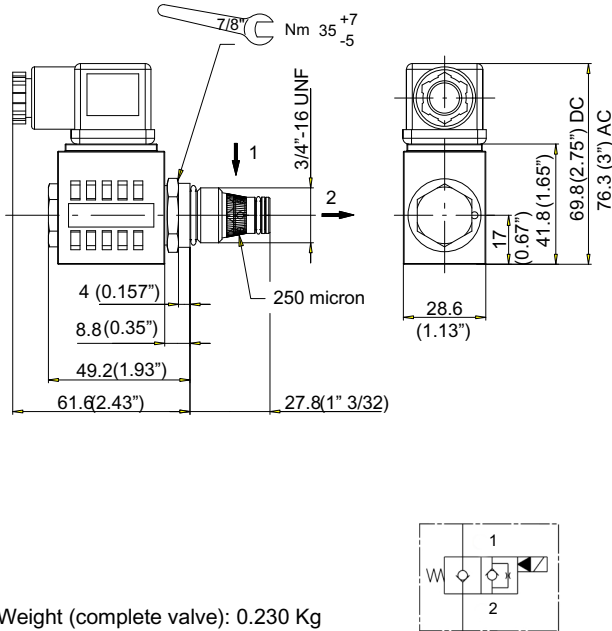

Weight (complete valve): 0.230 Kg

Electric performances	
Max. pressure	270 bar
Max. recommended pressure	230 bar
Max. flow	20 l/min.
Rated power	16 Watt
Intermittence	ED= 100%
Voltage tolerance	± 10%
Internal leakage	0-5 drops/min.
Temperature range	-20/+90 °C
Connector type	DIN 43650
Time to open 12 V 20 l/min 80% of final change of state	16 ms.
Time to close 12 V - 20 l/min 80% of final change of state	18 ms.
O-Ring replacement kit	200974200480

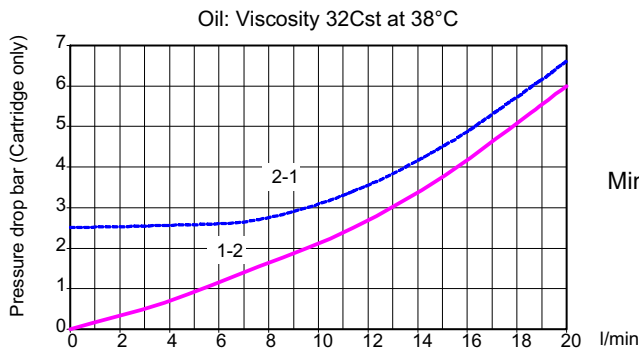

Minimum suggested working pressure = 5 bar

Directional valve without coil and connector

SPD817/22-TV P.M.	200757200930
-------------------	--------------

Coil voltage - A.C. supply requires a connector with bridge rectifier included.

18 Watt	D.C.		A.C.		
	12 V.	24 V.	24 V.	110 V.	220 V.
Type	13	23	21	41	51

Complete solenoid valve for A.C. current

Complete solenoid valve for D.C. current

SPD817/22-TV-13-HC	200957010084
SPD817/22-TV-23-HC	200957020076

SPD817/22-TV-21-HC	200956920052
SPD817/22-TV-41-HC	200956940047
SPD817/22-TV-51-HC	200956960053

**7.4.4 Solenoid operated directional valve:
SPE817/22-TV**

Normally closed Poppet type
Pilot type Flow from 1 to 2, not admitted from 2 to 1

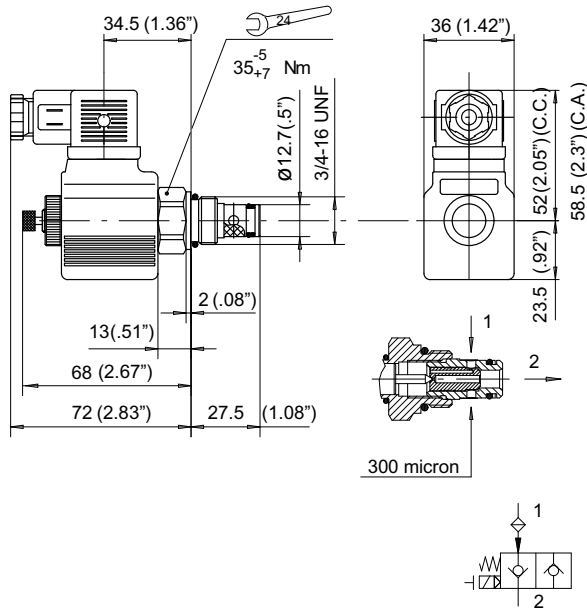

Weight (complete valve): 0.350 Kg

Electric performances	
Max. pressure	300 bar
Max. recommended pressure	230 bar
Max. flow	25 l/min.
Rated power	27 Watt
Intermittence	ED= 100%
Voltage tolerance	± 10%
Internal leakage	0-5 drops/min.
Temperature range	-20/+90 °C
Connector type	DIN 43650
Time to open (50-210 bar)	15-60 ms.
Time to close (50-210 bar)	15-60 ms.
O-Ring replacement kit	200974200140

Oil: Viscosity 37 mm²/s at 40°C

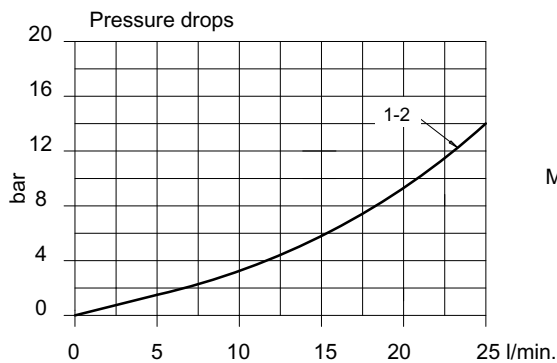

Directional valve without coil and connector

SPE817/22-TV P.M.	200757200550
-------------------	--------------

Coil voltage - A.C. supply requires a connector with bridge rectifier included.

27 Watt	D.C.		A.C.		
	12 V.	24 V.	24 V.	110 V.	220 V.
Type	13	23	21	41	51

Complete solenoid valve for A.C. current

SPE817/22-TV-21-HC27	200956920049
SPE817/22-TV-41-HC27	200956940044
SPE817/22-TV-51-HC27	200956960050

Complete solenoid valve for D.C. current

SPE817/22-TV-13-HC27	200957010070
SPE817/22-TV-23-HC27	200957022014

**7.4.5 Solenoid operated directional valve:
SPE817/22-TO**

Normally open Poppet type
Pilot type Flow from 1 to 2, not admitted from 2 to 1
With manual override

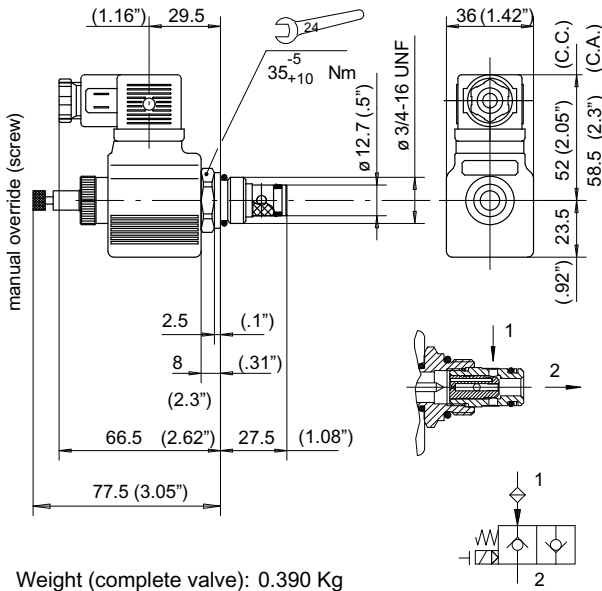

Weight (complete valve): 0.390 Kg

Electric performances	
Max. pressure	300 bar
Max. recommended pressure	210 bar
Max. flow	25 l/min.
Rated power	27 Watt
Intermittence	ED= 100%
Voltage tolerance	± 10%
Internal leakage	0-5 drops/min.
Temperature range	-20/+90° C
Connector type	DIN 43650
Time to open (50-210 bar)	15-60 ms.
Time to close (50-210 bar)	15-60 ms.
O-Ring replacement kit	200974200140

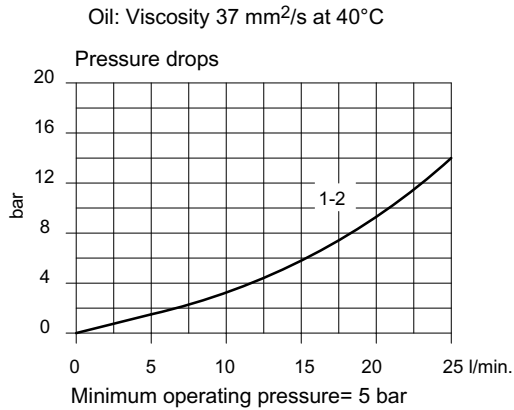

Directional valve without coil and connector

SPE817/22-TO P.M.	200757200540
-------------------	--------------

Complete solenoid valve for D.C. current

SPE817/22-TO-13-HC27	200957010071
SPE817/22-TO-23-HC27	200957020074

Coil voltage - A.C. supply requires a connector with bridge rectifier included.

27 Watt	D.C.		A.C.		
Volt	12 V.	24 V.	24 V.	110 V.	220 V.
Type	13	23	21	41	51

Complete solenoid valve for A.C. current

SPE817/22-TO-21-HC27	200956920051
SPE817/22-TO-41-HC27	200956940046
SPE817/22-TO-51-HC27	200956960052

7.4.6 Directional valve solenoids

SDF817 – SPE817 – SDR817 – SDRE817

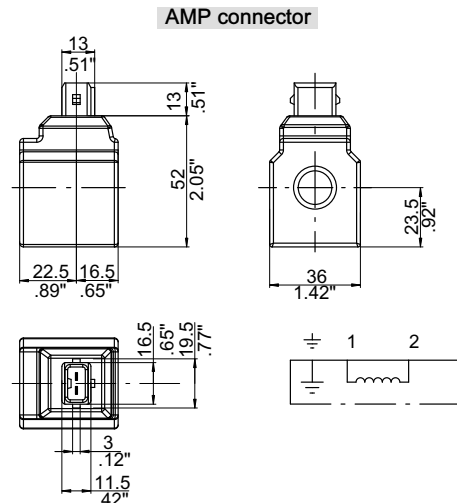
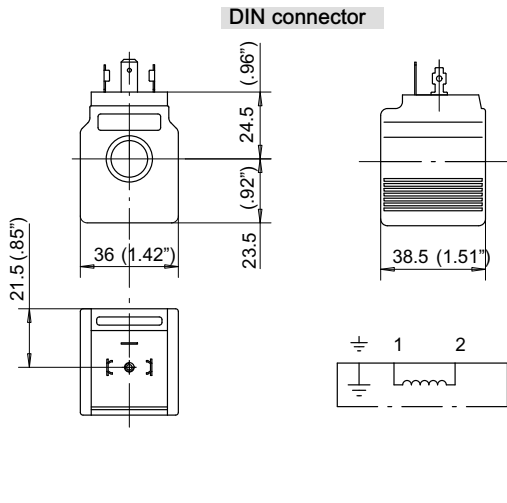

SPD
DIN connector

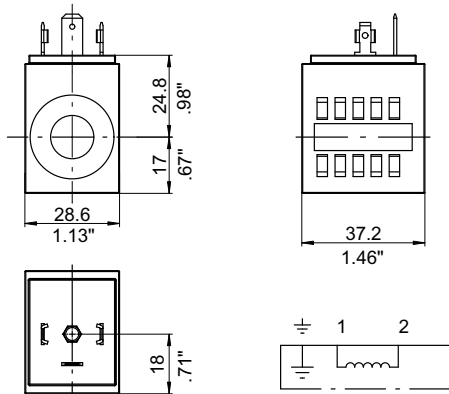

For solenoid valve series	SDF817 SDR817	SPE817 SDRE817	SPD
Wire class	H (VDE0580)		
Protection	IP65 (DIN40050)		
Coil insulation	F		
Duty rating	ED 100%		
Connector style	DIN 43650 or AMP84-9419		DIN 43650
Stabilized temperature	70°C		95°C (DC vers.)
Voltage tolerance	± 10%		

Connector style	Supply Voltage	Nominal Coil voltage	Power (Watt)	Resistance (Ohm)		Current (Ampere)		Coil code	
				Ambient temp.	Stabil. temp.	Ambient temp.	Stabil. temp.		
SDF - SDR - SDRE - SPE	DIN	12 V. DC.	12 V. DC.	27.2	5.3	8	2.2	1.5	200674910100
		24 V. DC.	24 V. DC.	27	21.3	32	1.12	0.75	200674920080
		48 V. DC.	48 V. DC.	27	85.3	130	0.56	0.37	200674930030
		24 V. AC.	21.6 V. DC.	27.1	17.2	26	1.25	0.83	200674820050
		110 V. AC.	98 V. DC.	27	355	530	0.27	0.18	200674840050
		220 V. AC.	198 V. DC.	27.6	1422	2130	0.14	0.10	200674860060
SDF - SDR - SDRE - SPE	AMP	12 V. DC.	12 V. DC.	27.2	5.3	8	2.2	1.5	200674910250
		24 V. DC.	24 V. DC.	27	21.3	32	1.12	0.75	200674920200
SPD	DIN	12 V. DC.	12 V. DC.	16	9	11.4	1.35	1.09	200541210039
		24 V. DC.	24 V. DC.	16	36	46.2	0.667	0.53	200541220037
		24 V. AC.	21.6 V. DC.	16	27.7	34.4	0.713	0.592	200541120015
		110 V. AC.	108 V. DC.	16	843	1053	0.15	0.1	200541140014
		220 V. AC.	216 V. DC.	16	3364	4168	0.624	0.498	200541160016

A.C. Supply requires a connector with bridge rectifier included

7.4.7 Connector for solenoid directional valves

Part number: 2005441.10009

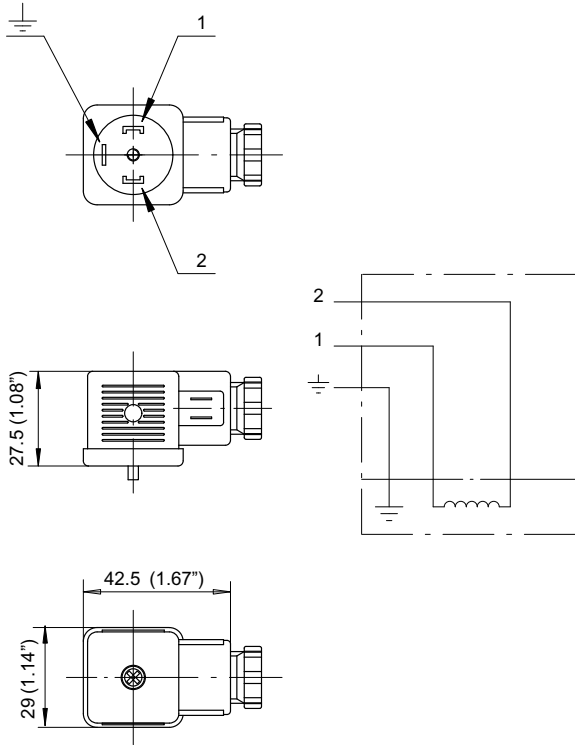

For power input	D.C.
Connector type	DIN 43650
Number of poles	2 + \perp
Supply voltage	max. 220 V.
Nom. capacity at contacts	10 A.
Max capacity at contacts	16 A.
Resistance at contacts	≥ 4 mOhm
Max section of cable	1.5 mm ²
Outer material	Glass fibre reinforced Nylon
Contact mount material	
Color	Black
Armour clamp	Pg 9
Ø cable	6-8 mm.
Protection factor	IP65 (DIN40050)
Insulation class	C (VDE0110)
Temperature range	-40 / +90 °C

Part number: 2005441.10012

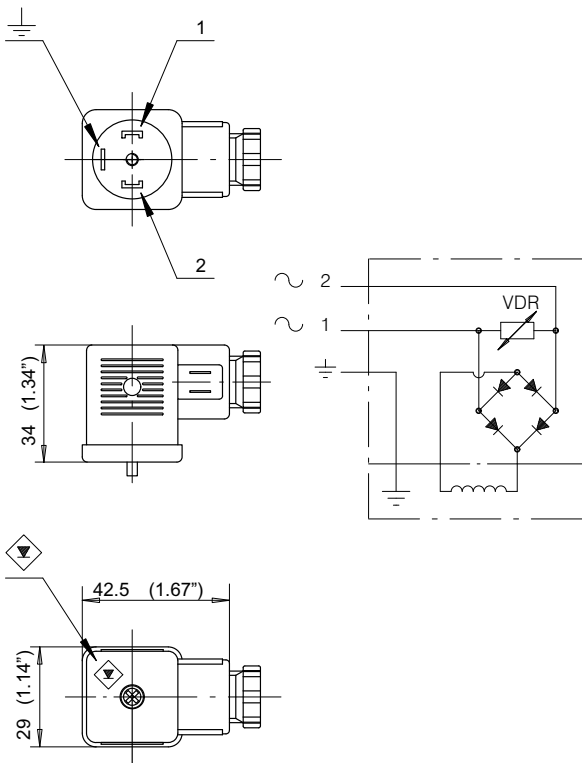

For power input	A.C.
Connector type	DIN 43650
Number of poles	2 + \perp
Supply voltage	max. 220 V.
Nominal capacity at contacts	10 A.
Max. capacity at contacts	16 A.
Resistance at contacts	≥ 4 mOhm
Max. section of cable	1.5 mm ²
Outer material	Glass fibre reinforced Nylon
Contact mount material	
Color	Black
Diodes	1N 4007 GP
Overvoltage protection	VDR
Armour clamp	Pg 9
Ø cable	6-8 mm.
Protection factor	IP65 (DIN40050)
Insulation class	C (VDE0110)
Temperature range	-40 / +90 °C

7.5 Proportional solenoid valve: PDF817/HSC

Normally closed

Poppet type

Pilot type

Flow from 1 to 2

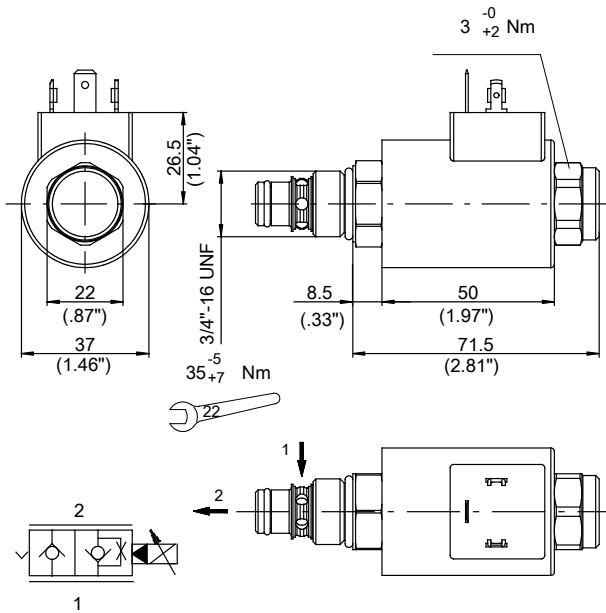

Electric performances		
	12 V	24 V
Resistance (at 20°C)	7.2 Ohms	22 Ohms
PWM frequency	100-150 Hz PWM frequency	
Connection type	DIN 43650	
Max current, non continuous Duty	1500 mA	1000 mA
Max current, continuous Duty	1200-1250 mA	800-850 mA
Minimum current	350-400 mA	200-250 mA
Other connectors available	(DIN), AMP JT	
Seal kit code	200599999630	

Code	PDF817/HSC-HC (12 V) 200957110004	With DIN coil, without connector

Flow (l/min) vs. Current (mA - PWM @ 100 Hz) at various differential pressures (bar) @ 50°C

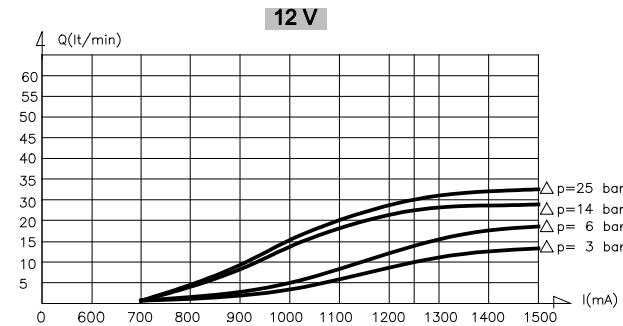

Typical hysteresis

Oil: Viscosity 37 mm²/s at 40°C

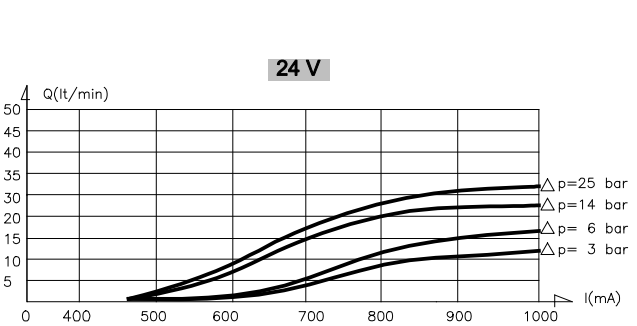
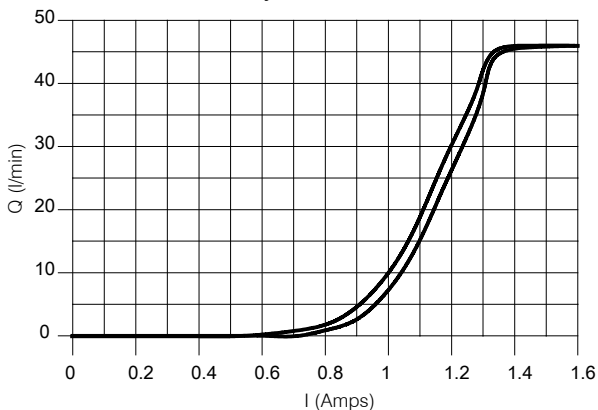

Typical hysteresis

Oil: Viscosity 37 mm²/s at 40°C

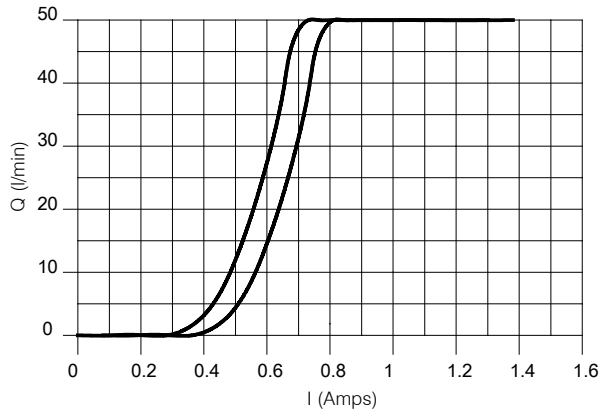

7.5.1 Electric connectors to control proportional valves

Ordering code	200544110031
Connector type	DIN 43650
PWM dither frequency	55-200 Hz (adjustable)
Operating temperature	-25 °C / +85 °C
Adjustable ramp time	0.05- 5 sec.

Current output range (PWM)	100-3000 mA
Degree of protection	IP 67
Analog input signal (*)	0-5V
Input impedance	50 kOhm
Typical ctrl pot resistance	2-47 kOhm

(*) Other analog input signal on demand (0-10 V or 0-20 mA)

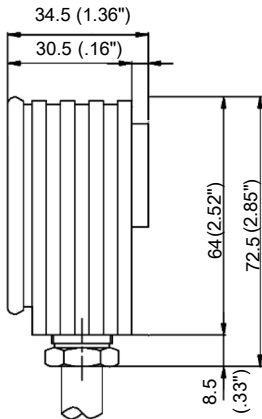

4x0.5 CABLE - Length = 700 mm

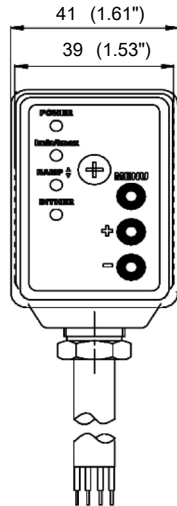

(DIN 43650 female socket)

Power supply wiring colours

Blue: Positive from Powe source
Yellow/Green: Negative from

Remote potentiometer wiring colours

Black: command signal supply (+5V)
Brown: command signal in

Proportional valves wiring colours

1 : proportional coil output
2 : proportional coil current feedback line

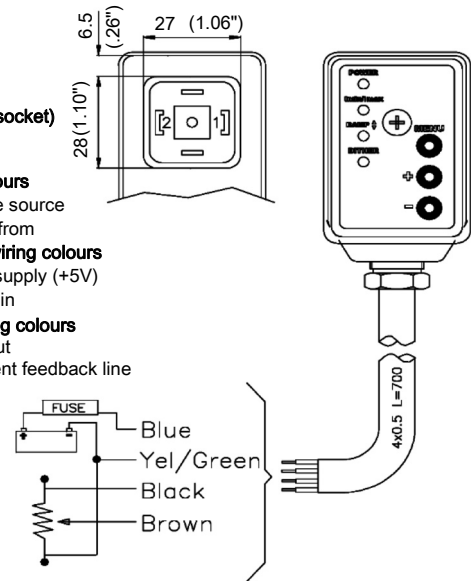

IMPORTANT! Other type of electric connectors and electronic cards are available.
See www.bucherhydraulics.com

7.6 Manual override valves

7.6.1 Manual override valve: NV1/817-R

Manual override
Flow restrictor
Poppet type
Flow from 1 to 2
Code

200787601601

Max. pressure 230 bar
Max. flow 25 l/min.
Internal leakage 0-5 drops/min.
Temperature range -20/+90 °C
O-Ring replacement kit 200974200160
Weight 0.110 Kg.

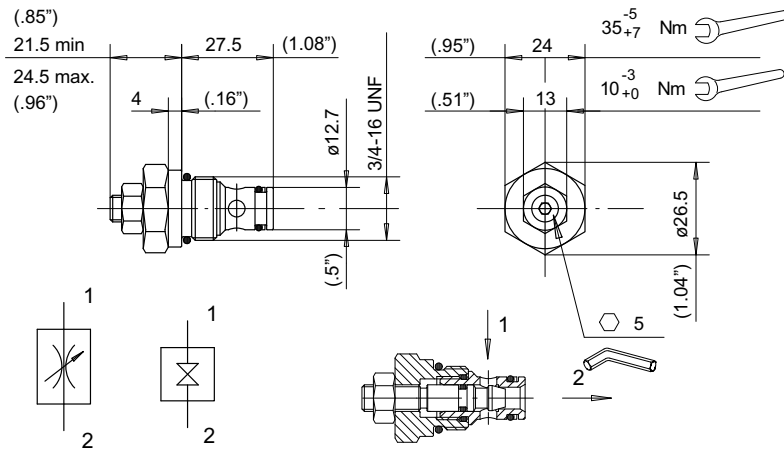

Oil: Viscosity 37mm²/s at 40°C

Pressure drops with restrictor open

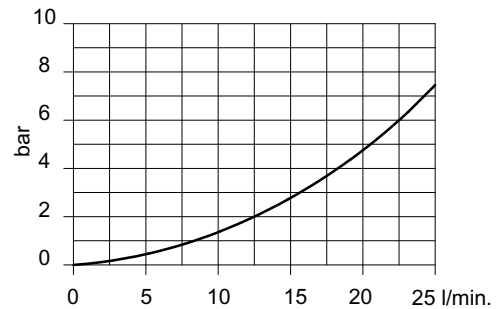

7.7 Directional valves

7.7.1 Directional valve: EPP817/22-TV

Manually operated
Push to open
Poppet type
Flow from 1 to 2

Max. pressure 230 bar
Max. flow 25 l/min.
Internal leakage 0-5 drops/min.
Temperature range -20/+90 °C
O-Ring replacement kit 200974200160
Weight 0.140 Kg.

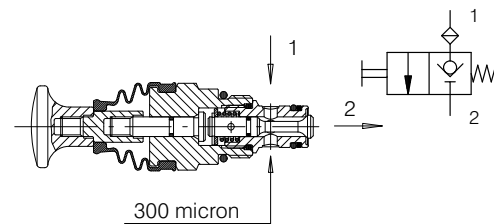
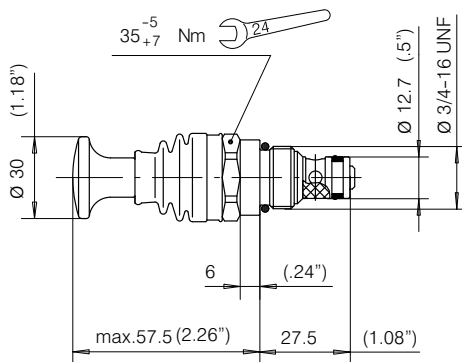

Oil: Viscosity 37mm²/s at 40°C

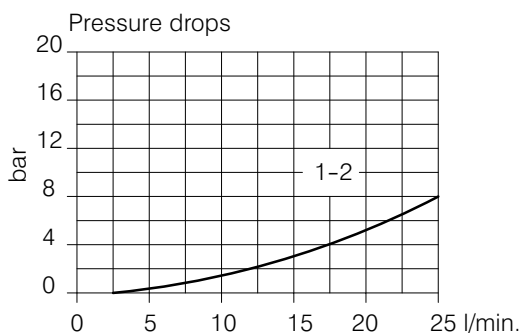

The **EPP817/...** comes complete with a knob allowing rapid operation, and a boot of plastic material to exclude dust, dirt, etc.

In this version, the knob is fitted with a stroke limiter to prevent possible damage to internal parts.

Type	Code
EPP817/22-TV	200787601680

7.7.2 Directional valve: VPE817/22-TV-A

Pilot operated
External connection
Poppet type
Flow from 1 to 2

Max. pressure 230 bar
Max. flow 25 l/min.
Internal leakage 0-5 drops/min.
Temperature range -20/+90 °C
O-Ring replacement kit 200974200160
Weight 0.130 Kg.

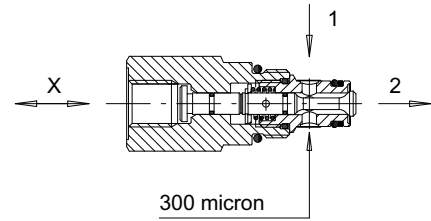
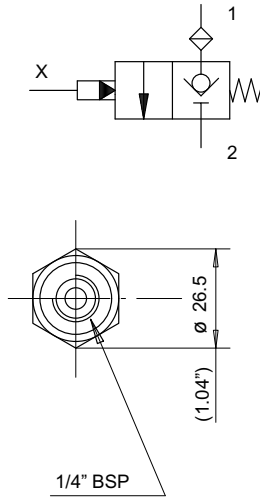
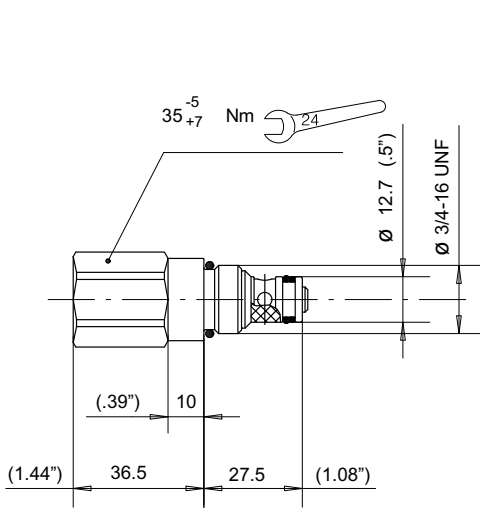

VPE817/22-TV-A

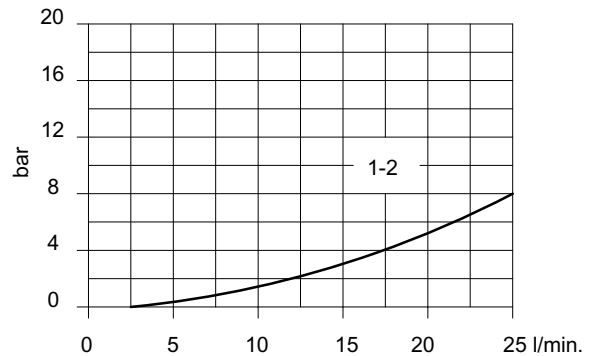
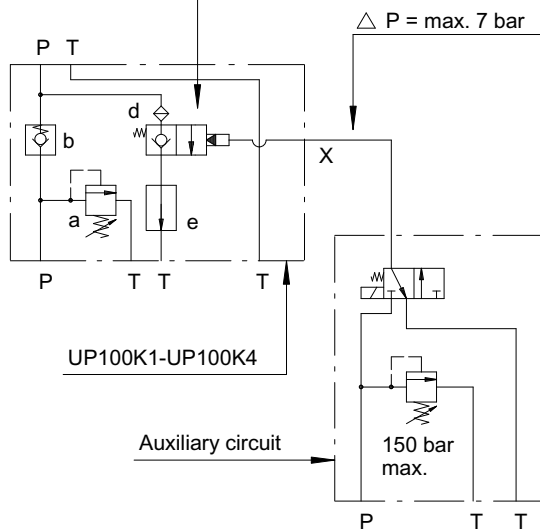

This is a pilot operated directional valve, two-way two-position series, with external pilot connection.

The connection of ports 1 and 2 across the valve is obtained by pressurizing the pilot chamber X from an external circuit. Pilot pressure difference to shift is 14 bar approx.

As illustrated in the hydraulic diagram alongside, the pilot chamber X must be connected to tank so as to ensure that the valve cannot be opened involuntarily by back pressure. Care must be taken that the pressure loss and maximum pressure values indicated in the diagram are not exceeded.

Pilot port	Type	Code
1/4" BSP	VPE817/22-TV-A	200787601740

7.8 Flow control valves

7.8.1 Flow control valve: VRC818/**-F

Compensated
 Fixed setting
 Seven pre-set flow values
 Flow from 2 to 1

Max. pressure 230 bar
 Max. flow 30 l/min.
 Controlled flow rate see table
 Tolerance $\pm 15\%$
 Temperature range $-20/+90\text{ }^{\circ}\text{C}$
 O-Ring replacement kit 200974200150
 Weight 0.090 Kg.

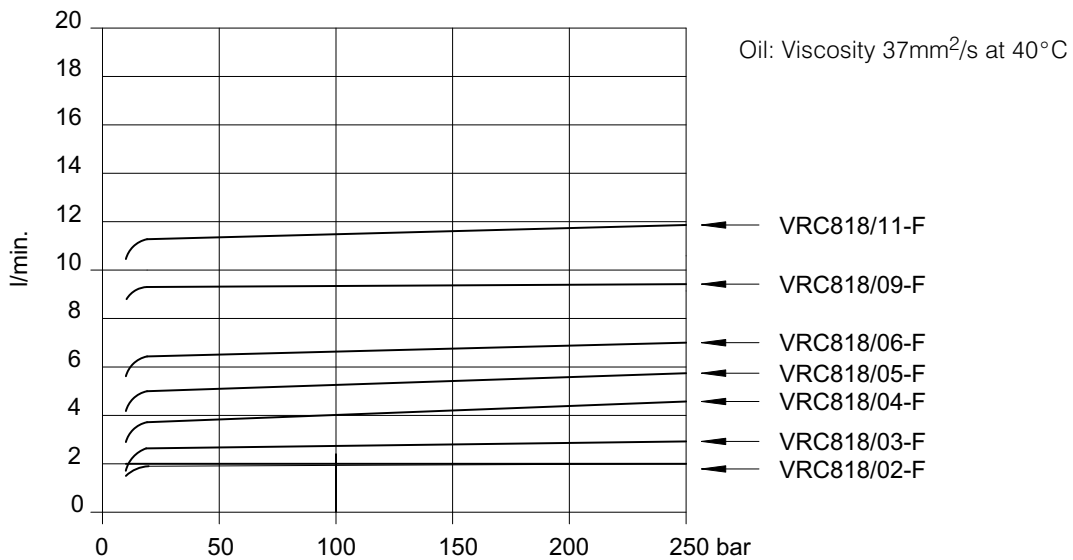
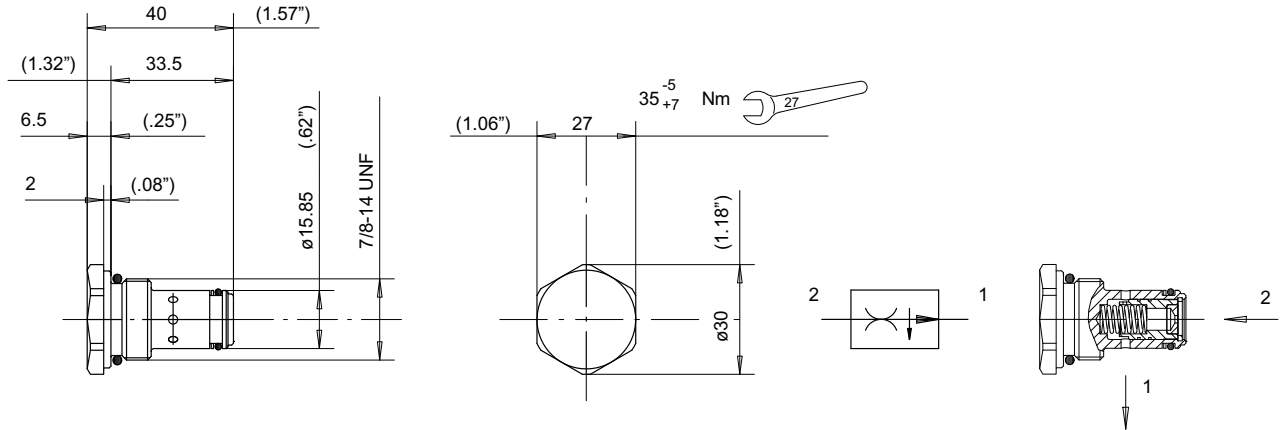

	Nominal flow	Ø X	Type	Code
	2 l/min.	1.25	VRC818/02-F	200787200790
	3 l/min.	1.50	VRC818/03-F	200787200780
	4 l/min.	2.00	VRC818/04-F	200787200770
	5 l/min.	2.25	VRC818/05-F	200787200760
	6 l/min.	2.50	VRC818/06-F	200787200750
	9 l/min.	3.00	VRC818/09-F	200787200740
	11 l/min.	3.50	VRC818/11-F	200787200730

7.8.2 Flow control valve: VRC818/*-R

Compensated
Adjustable setting
Two setting flow ranges
Flow from 2 to 1

Max. pressure 250 bar
Max. flow 50 l/min.
Controlled 1-6 l/min.
..... 5-30 l/min.
Temperature range -20/+90 °C
O-Ring replacement kit 200974200150
Weight 0.260 Kg.

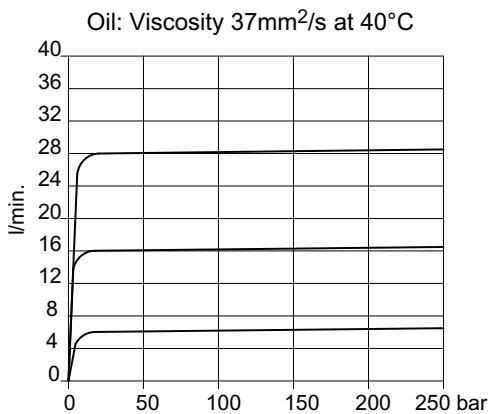
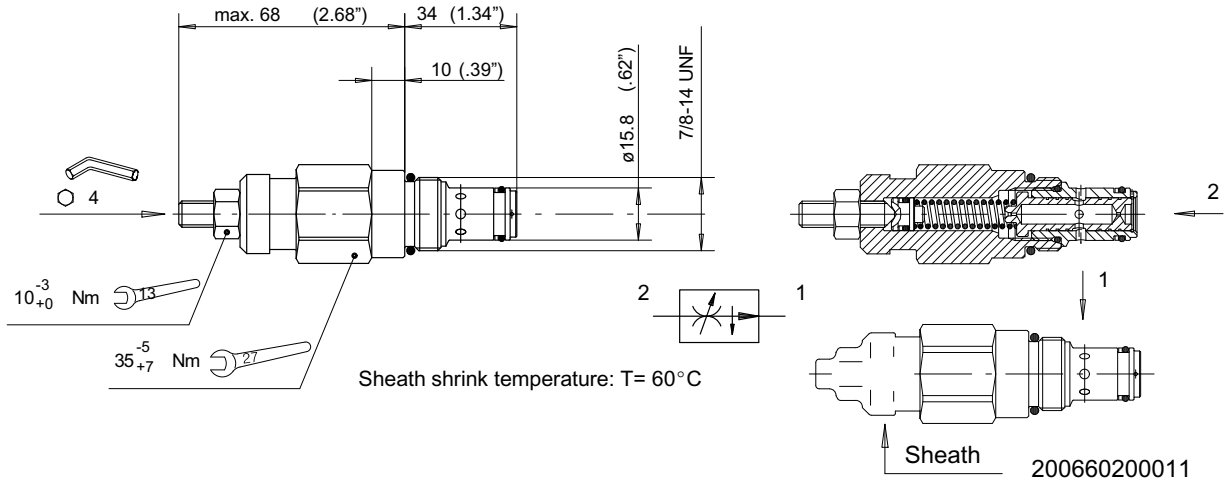

A heat-shrinkable sheath can be supplied, if requested to prevent the valve being tampered with.

When ordering, state in full the sheath part number, and, if the valve is to be supplied with sheath already fitted, the flow value setting required.

Setting range	Type	Code
1-6 l/min.	VRC818/A-R	200787200830
5-30 l/min.	VRC818/B-R	200787200840

Fixed version

VRC818/*-F**

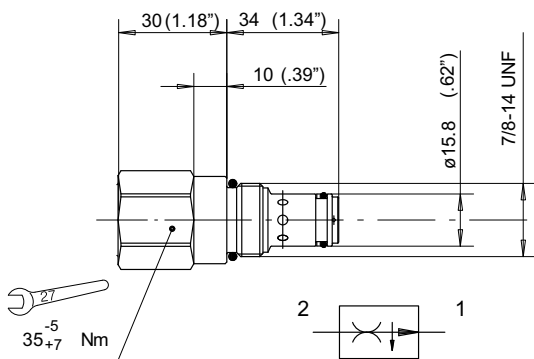

Nominal flow (l/min) ±12%	Type	Code
10	VRC818/D-F10	200787201490
12	VRC818/C-F12	200787200850
20	VRC818/B-F20	200787200970
30	VRC818/B-F30	200787201030

7.8.3 Flow control valve: VRC01/**

Compensated
 Fixed setting
 Seven pre-set flow values
 Flow from E to U

Max. pressure 230 bar
 Controlled flow rate see table
 Tolerance $\pm 15\%$
 Performances see VRC818/*F
 Temperature range $-20/+90\text{ }^{\circ}\text{C}$
 Weight 0.060 Kg.
 Max. U-E flow rate = max. + 30% of E-U flow

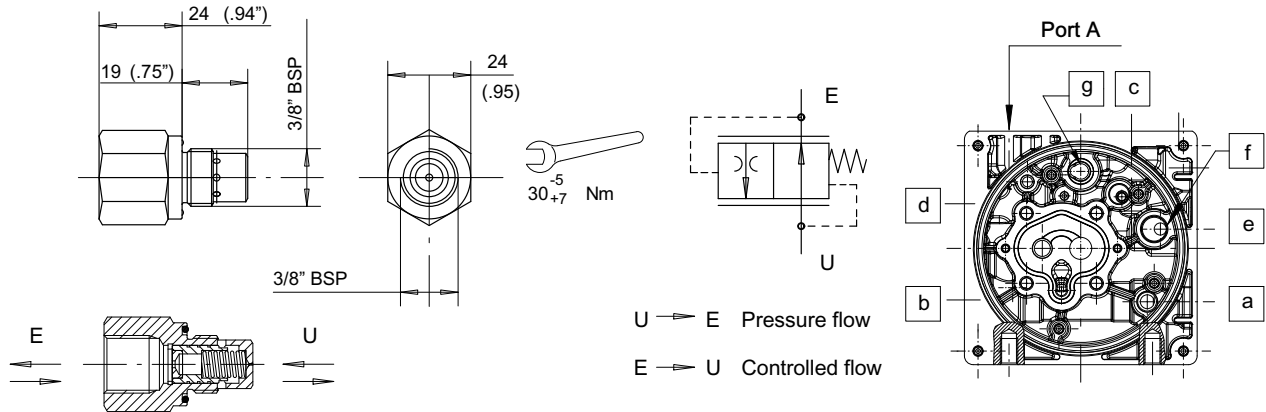

The VRC01 flow control valve can be installed in any power pack housing with 3/8" BSP pressure port E.G. Type **UP100K1G3** housing.

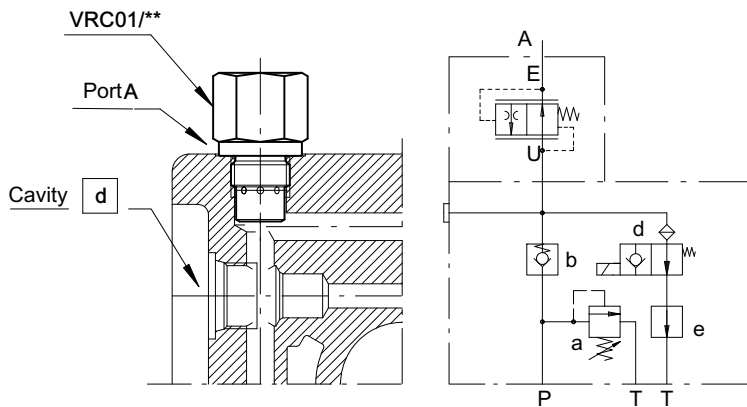

The VRC01 can be utilized in all those applications which make use of a normally open solenoid operated unloading valve. With this arrangement, pump flow is unloaded to tank with the lowest pressure drop.

In view of the particular type of construction, it is important not to exceed the indicated ratio between pressure flow (free reverse flow through the valve) and the controlled flow when unloading.

	Nominal flow	Ø X	Type	Code
	2 l/min.	1.25	VRC01/2	200787200030
	3 l/min.	1.50	VRC01/3	200787200040
	4 l/min.	2.00	VRC01/4	200787200050
	5 l/min.	2.25	VRC01/5	200787200060
	6 l/min.	2.50	VRC01/6	200787200070
	9 l/min.	3.00	VRC01/9	200787200080
	11 l/min.	3.50	VRC01/11	200787200010

7.9 Manual lowering valve

7.9.1 Manual lowering valve: ZR817/22-TV

For housings:

UP100/K1

UP100/K4

Normally closed

Code 200987601960
 Max. pressure 230 bar
 Max. recommended pressure 210 bar
 Max flow 25 l/min.
 Internal leakage 0-5 drops/min.
 Temperature range -20/+90 °C
 O-Ring replacement kit 200974200160

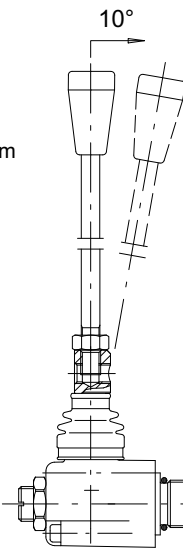
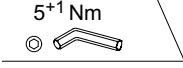
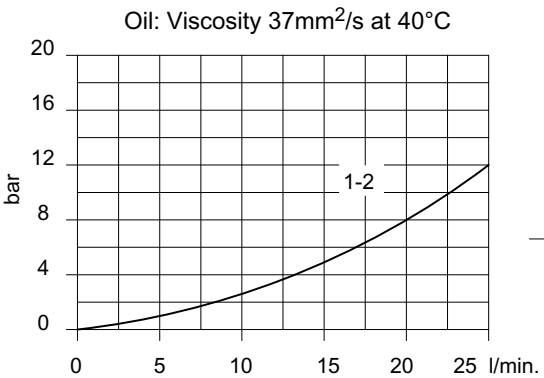
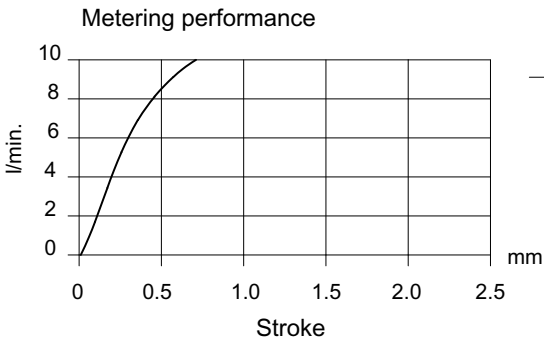
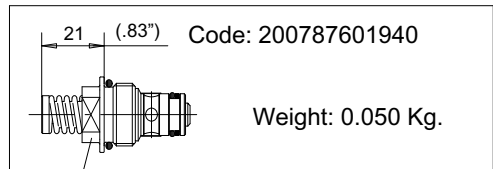
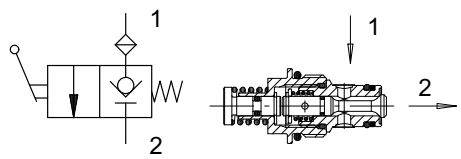
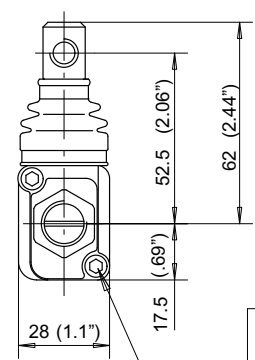
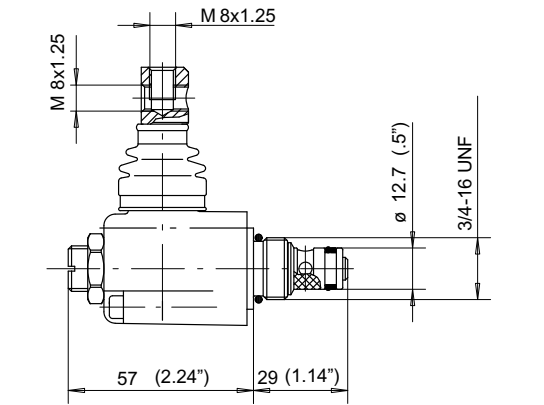

The connecting end of the lever allows the handle to be mounted in two different positions.

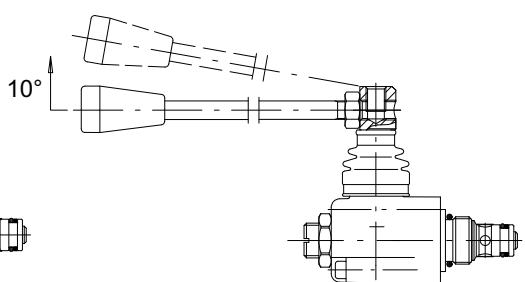

Mounting positions: L10-L12-L14-L16 (see 7.9.2)

Lever stick

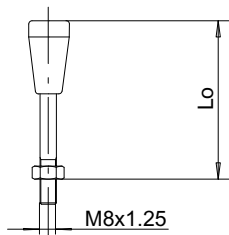
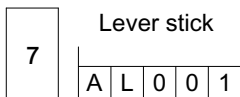

Lo Length	Type	Code
150 mm-5.90 inches	AL001	200702210190
200 mm-7.87 inches	AL002	200702210030
250 mm-9.84 inches	AL003	200702210050
300 mm-11.80 inches	AL004	200702210060

7.9.2 Manual lowering valve mounting positions

Mounting allowed in housing types K1-K4

Cavity **d**

Type of housing										Vers.		
1	U	P	1	0	0	K	*	*	*	*	*	*

Cavity d												
7	Z	R	8	1	7	/	2	2	-	T	V	

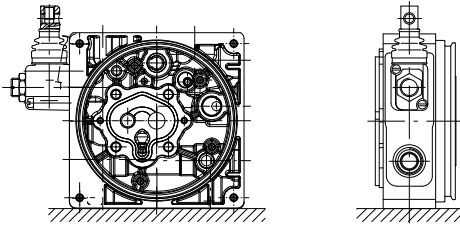

Hand lever
L 1 0

Lever stick
A L 0 0 *

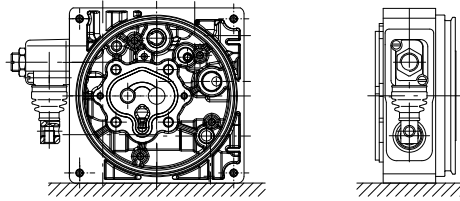

Hand Lever
L 1 2

Lever stick
A L 0 0 *

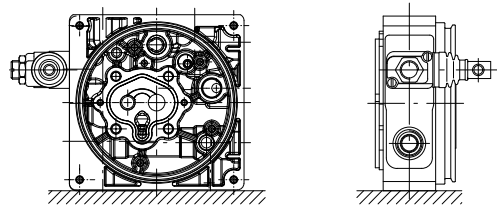

Hand lever
L 1 4

Lever stick
A L 0 0 *

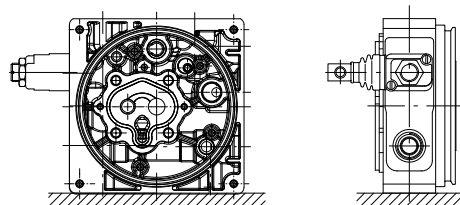

Hand lever
L 1 6

Lever stick
A L 0 0 *

Mounting allowed in housing type K1

Cavity **c**

Type of housing										Vers.	
1	U	P	1	0	0	K	1	*	*	*	*

Cavity c												
7	Z	R	8	1	7	/	2	2	-	T	V	

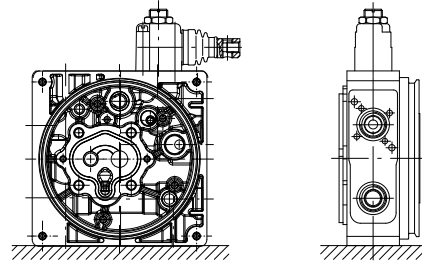

Hand lever
L 1 0

Lever stick
A L 0 0 *

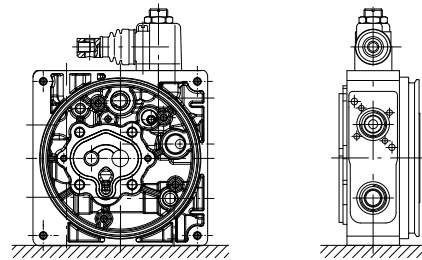

Hand lever
L 1 2

Lever stick
A L 0 0 *

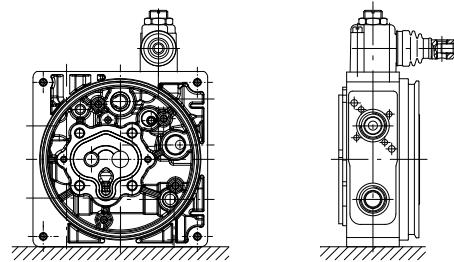

Hand lever
L 1 4

Lever stick
A L 0 0 *

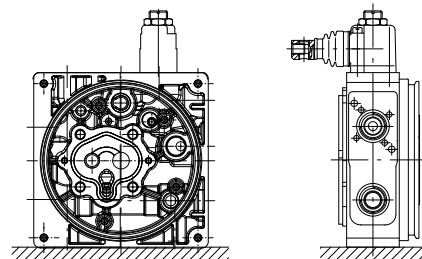

Hand lever
L 1 6

Lever stick
A L 0 0 *

7.9.3 Manual lowering valve with microswitch: ZR817/22-TVM

For housings:

UP100/K1

UP100/K4

Normally closed

Code 200987601950

Max. pressure 230 bar
 Max. recommended pressure 210 bar
 Max. flow 25 l/min.
 Internal leakage 0-5 drops/min.
 Temperature range -20/+90 °C
 O-Ring replacement kit 200974200160

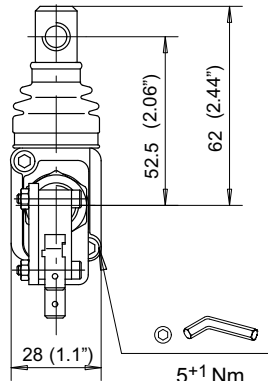
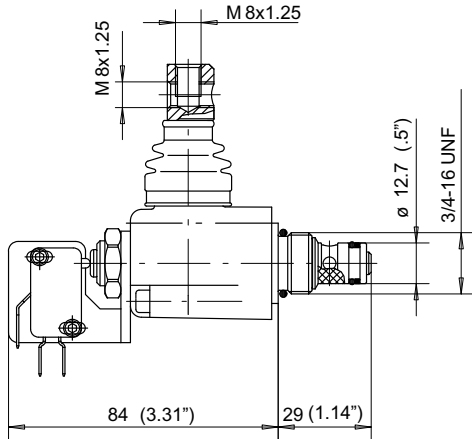

Microswitch performances see chapter 10

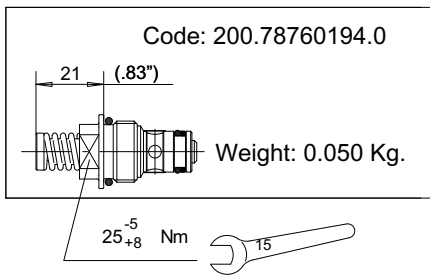
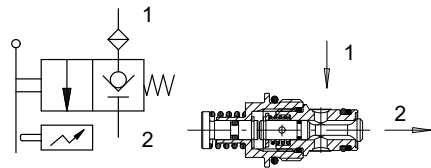

Code: 200.78760194.0

Weight: 0.050 Kg.

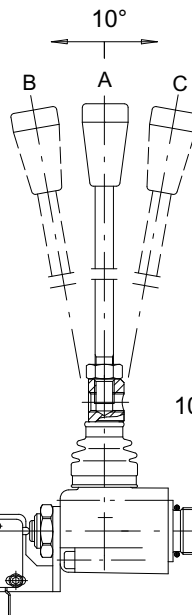

A " B = Microswitch operated
 A " C = Hydraulically operated

The connecting end of the lever allows the handle to be mounted in two different positions.

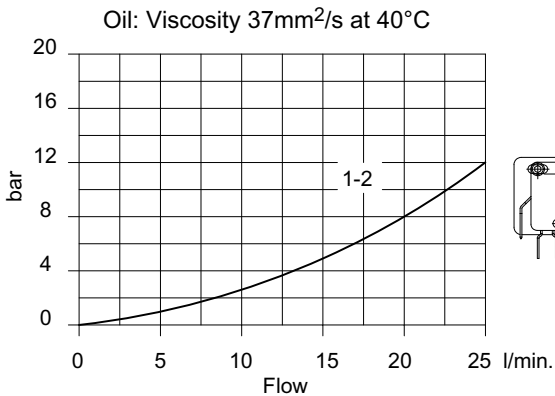

Mounting positions: L10-L12-L14-L16 (see 7.9.2)

Lever stick

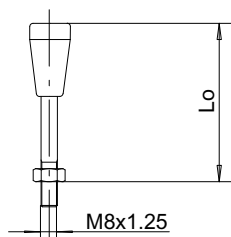
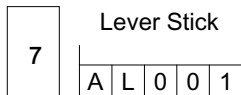

L ₀ Length	Type	Code
150 mm-5.90 inches	AL001	200702210190
200 mm-7.87 inches	AL002	200702210030
250 mm-9.84 inches	AL003	200702210050
300 mm-11.80 inches	AL004	200702210060

7.9.4 Manual lowering valve without microswitch and safety lever support: ZR817/22-TVS

For housings:

UP100/K1

UP100/K4

Normally closed

Code 200987601970

Max. Pressure 230 bar
 Max recommended pressure 210 bar
 Max. Flow 25 l/min.
 Internal Leakage 0-5 drops/min.
 Temperature range -20/+90 °C
 O-Ring replacement kit 200974200160

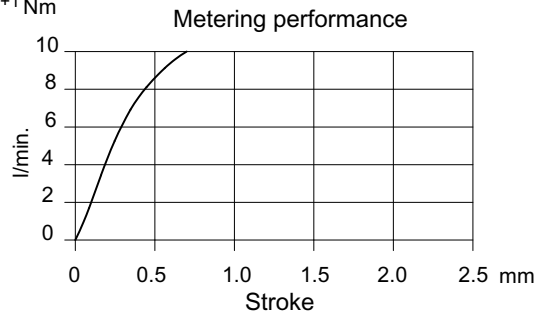
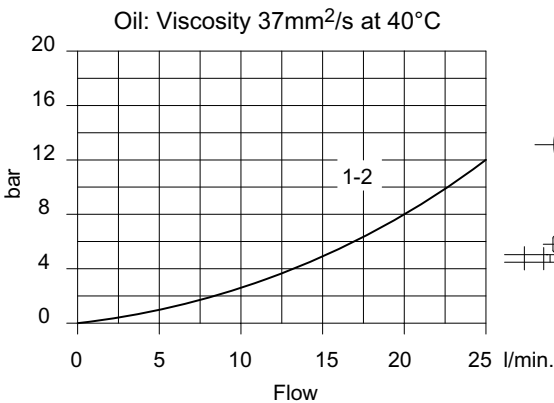
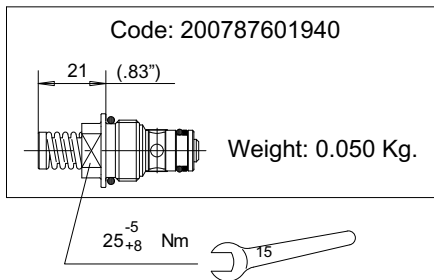
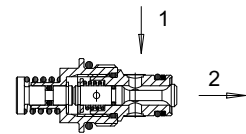
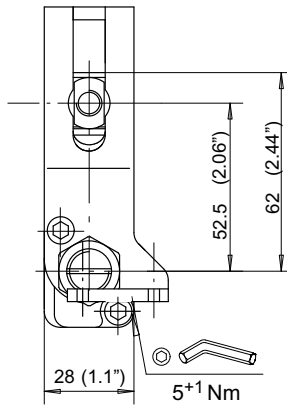
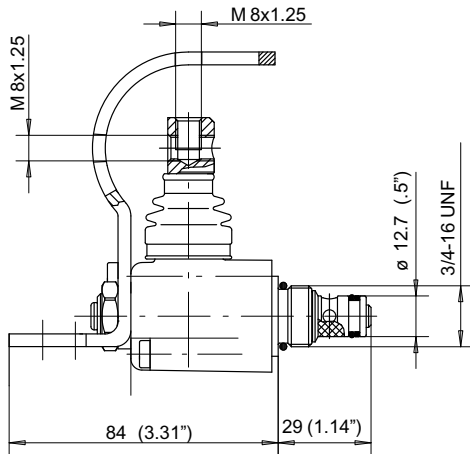

The connecting end of the lever allows the handle to be mounted in two different positions.

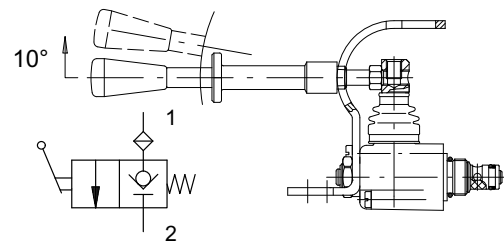
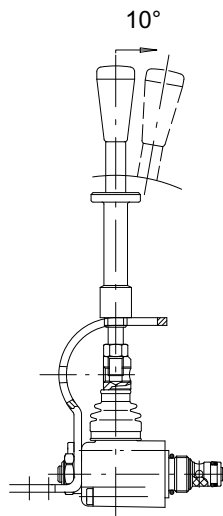

Mounting positions: L10-L14-L16 (see 7.9.2)

Lever Stick

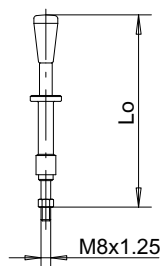
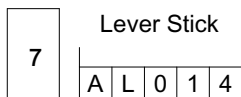

L ₀ Length	Type	Code
160 mm-6.29 inches	AL014	200702210090
122 mm-4.82 inches	AL002	200702210040

7.9.5 Manual lowering valve with microswitch and safety lever support: ZR817/22-TVMS

For housings:

UP100/K1

UP100/K4

Normally closed

Code 200987601980

Max. pressure 230 bar
 Max. recommended pressure 210 bar
 Max flow 25 l/min.
 Internal leakage 0-5 drops/min.
 Temperature range -20/+90 °C
 O-Ring replacement kit 200974200160

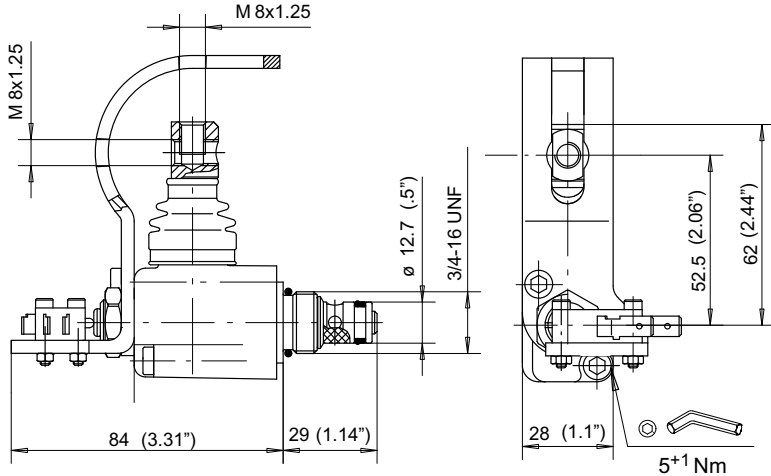

Microswitch performance: see chapter 10

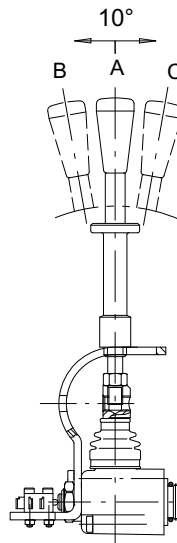
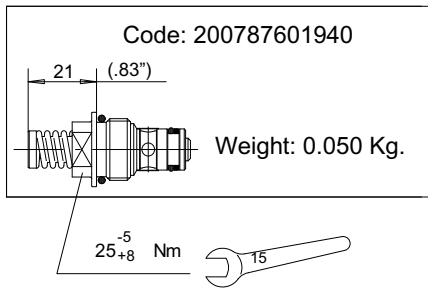
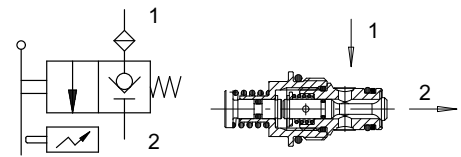

A " B = Microswitch operated

A " C = Hydraulically operated

The connecting end of the lever allows the handle to be mounted in two different positions.

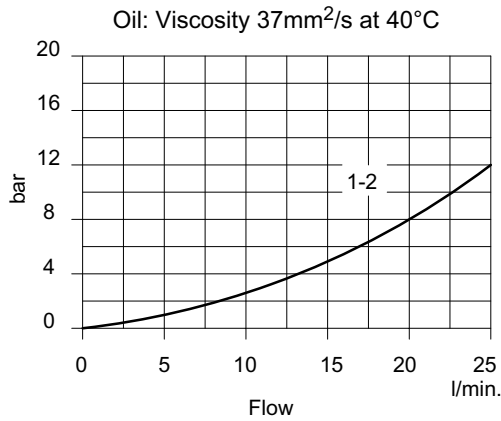
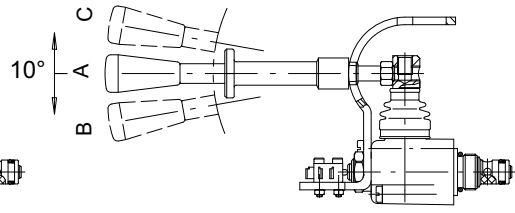

Mounting positions: L10-L14-L16 (see 7.9.2)

Lever Stick

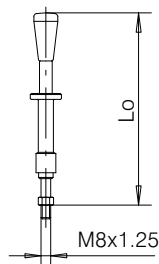
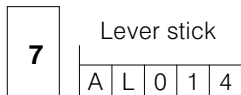

L ₀ Length	Type	Code
160 mm-6.29 inches	AL014	200702210090
122 mm-4.82 inches	AL002	200702210040

7.9.6 Manual lowering valve: Z817/22-HS

For housings:

UP100/K1

UP100/K4

Normally closed

High sensibility

Code 200987601800

Max. pressure 230 bar

Max. recommended pressure 210 bar

Max. flow 25 l/min.

Internal Leakage 0-5 drops/min.

Temperature range -20/+90 °C

O-Ring replacement 200974200160

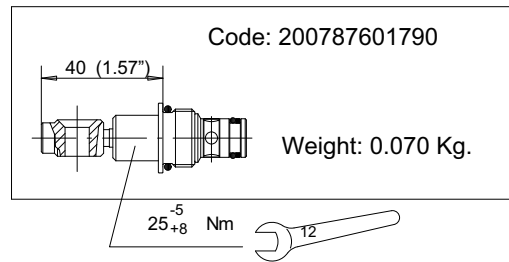
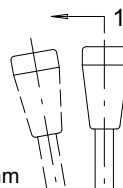
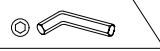
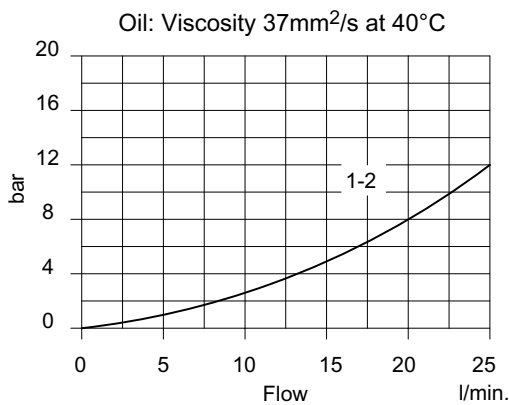
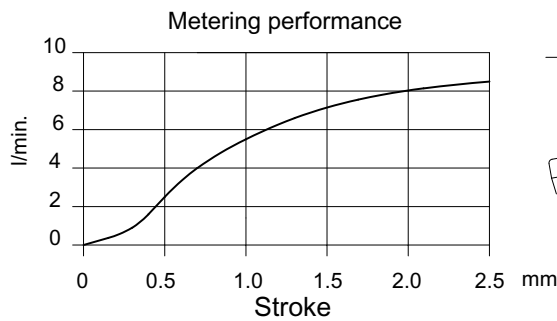
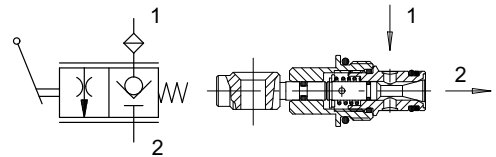
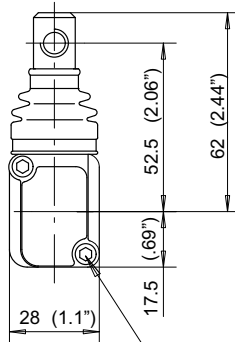
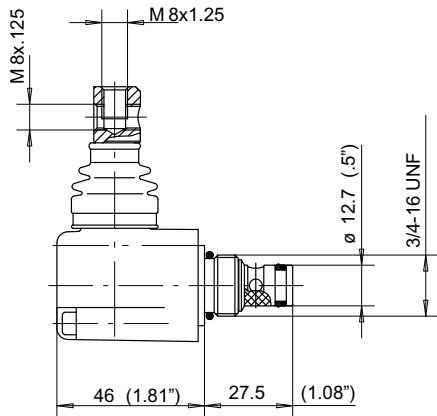

Code: 200787601790

Weight: 0.070 Kg.

The connecting end of the lever allows the handle to be mounted in two different positions.

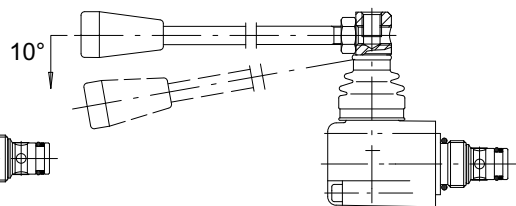

Mounting positions: L10-L12-L14-L16 (see 7.9.2)

Lever stick

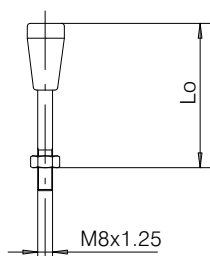
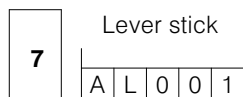

L ₀ Length	Type	Code
150 mm-5.90 inches	AL001	200702210190
200 mm-7.87 inches	AL002	200702210030
250 mm-9.84 inches	AL003	200702210050
300 mm-11.80 inches	AL004	200702210060

7.10 Emergency hand pumps

7.10.1 Emergency hand pump: PM817/1.5

For housings:

UP100/K1G2-19 and UP100K4P0-01

Inlet check

Outlet check

Ball type

Code 200948200080

Max recommended pressure 210 bar

Displacement 1.5 cm³

Internal leakage 0-5 drops/min.

Temperature range -20/+90 °C

O-Ring replacement kit 200974200340

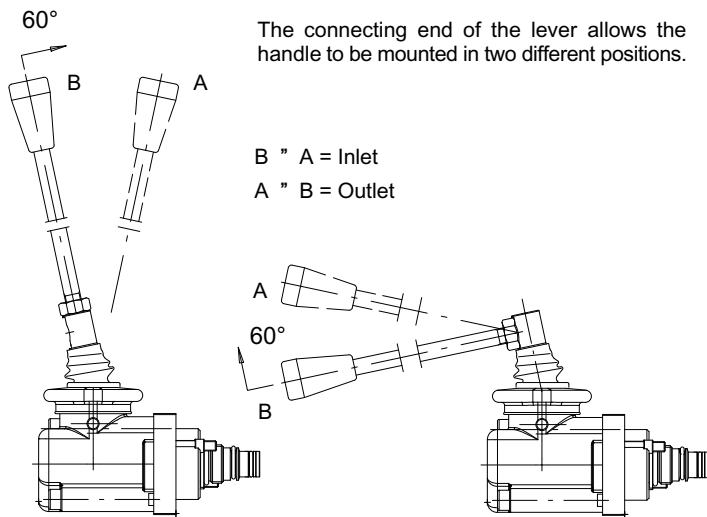
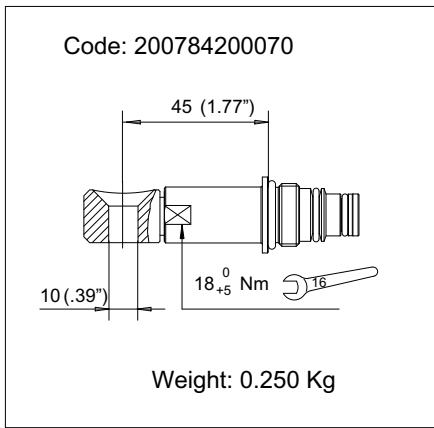
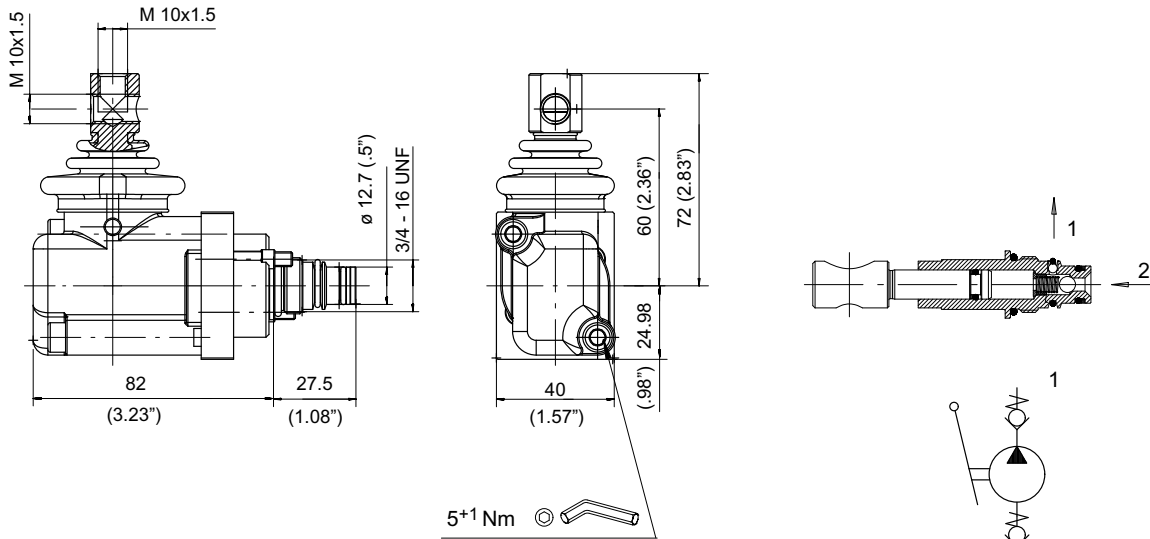

The connecting end of the lever allows the handle to be mounted in two different positions.

B " A = Inlet
A " B = Outlet

Mounting positions: L10-L12-L14-L16 (see 7.10.2)

With the hand pump assembled into either cavity C a suction pump having proper length, in function of the type and capacity of the tank has to be fitted into the appropriate cavity (see next page).

Lever stick

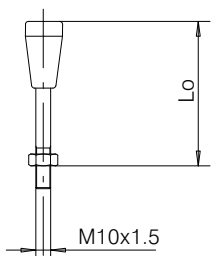
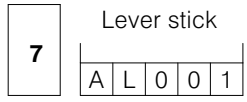

L ₀ Length	Type	Code
185 mm-7.28 inches	AL001	200702220010
250 mm-9.84 inches	AL002	200702220030
300 mm-11.81 inches	AL003	200702220040
350 mm-13.78 inches	AL004	200702220050

7.10.2 Emergency hand pump PM817/1.5 positions

Mounting allowed in housing type **K1G2-19** Cavity

c

	Type of housing	Vers.
1	U P 1 0 0 K 1 G 2	1 9

	Cavity C
7	P M 8 1 7 / 1 . 5

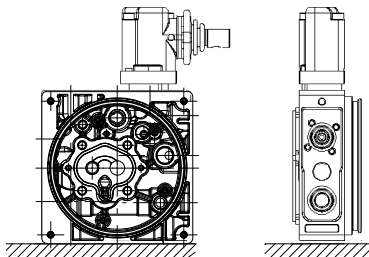

Hand lever
L 1 0

Lever stick
A L 0 0 *

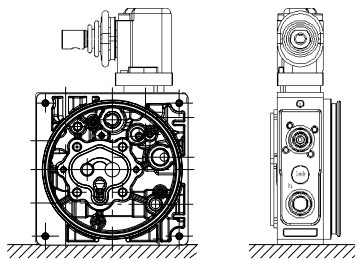

Hand Lever
L 1 2

Lever stick
A L 0 0 *

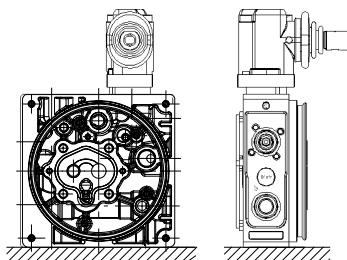

Hand lever
L 1 4

Lever stick
A L 0 0 *

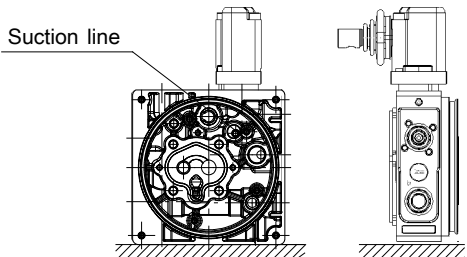

Hand lever
L 1 6

Lever stick
A L 0 0 *

Mounting allowed in housing type **K3P0-01** with manifold **4217**

	Type of housing	Vers.
1	U P 1 0 0 K 3 P 0	0 1

	Cavity	Manifold
7	P M 8 1 7 / 1 . 5	8 4 2 1 7

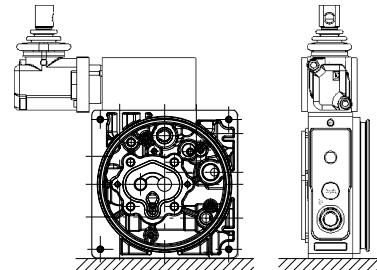

Hand lever
L 1 0

Lever stick
A L 0 0 *

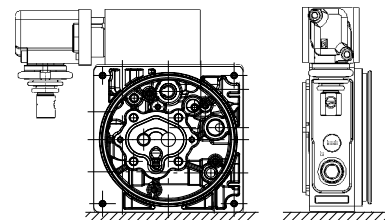

Hand lever
L 1 2

Lever stick
A L 0 0 *

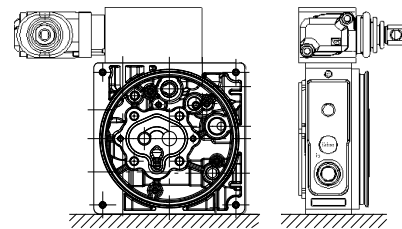

Hand lever
L 1 4

Lever stick
A L 0 0 *

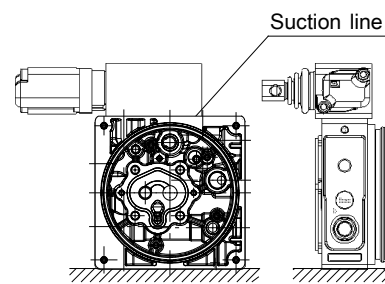

Hand lever
L 1 6

Lever stick
A L 0 0 *

7.11 Valve cavity plugs

7.11.1 Valve cavity plug T817/0

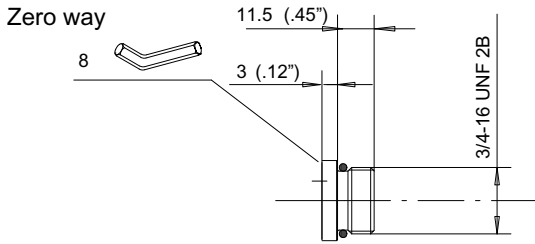

Code	200527481701
O-Ring code	200514224711
Weight	0.040 Kg.

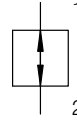

7.11.2 Valve cavity plug T817/2

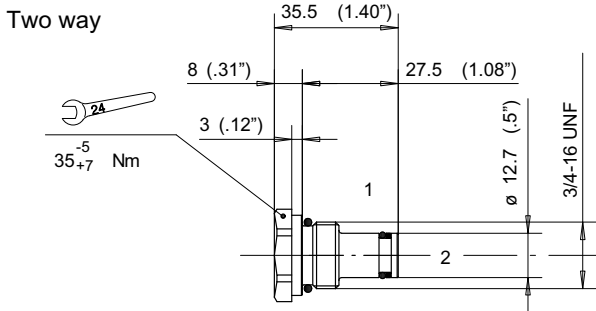

Code	200778800020
Seal kit code	200974200160
Weight	0.070 Kg.

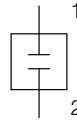

7.11.3 Valve cavity plug T818/0

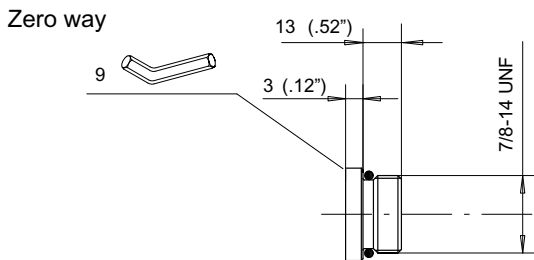

Code	200527481801
O-Ring code	200514231511
Weight	0.080 Kg.

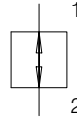

7.11.4 Valve cavity plug T817/2P-602

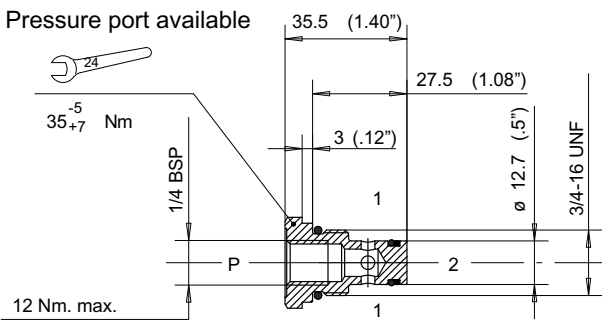

Code	200778800060
Seal kit code	200974200160
Weight	0.040 Kg.

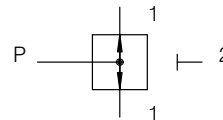

7.11.5 Valve cavity plug T817/2T-602

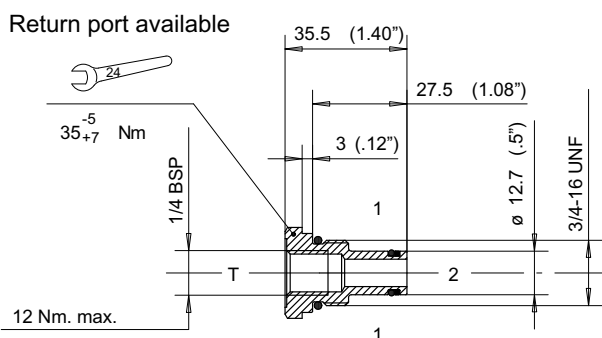

Code	200778800070
Seal kit code	200974200160
Weight	0.030 Kg.

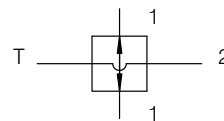

7.11.6 Example of plugs fitted into valve cavities

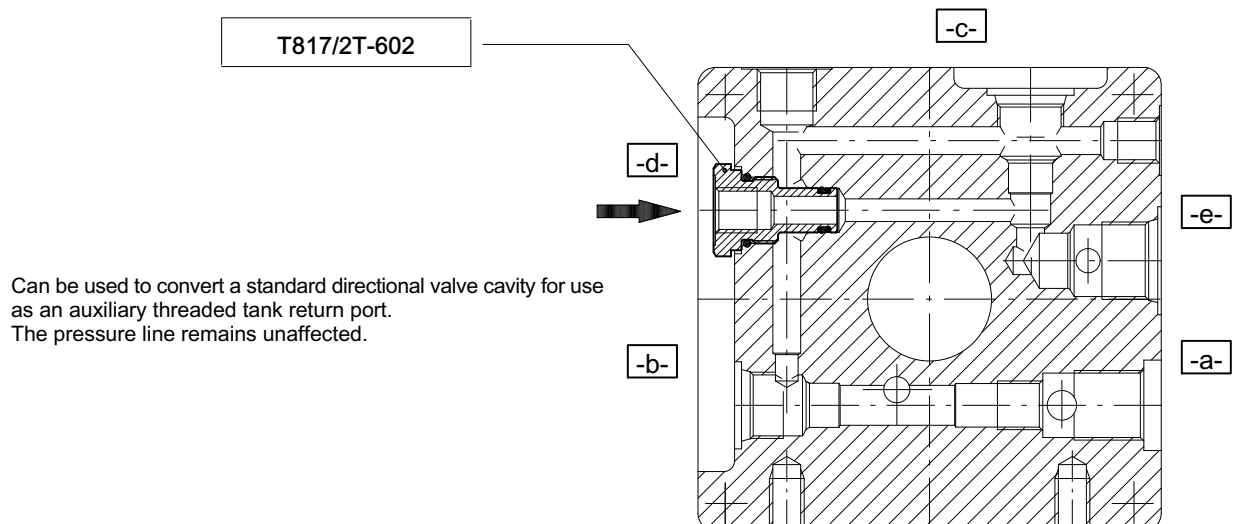
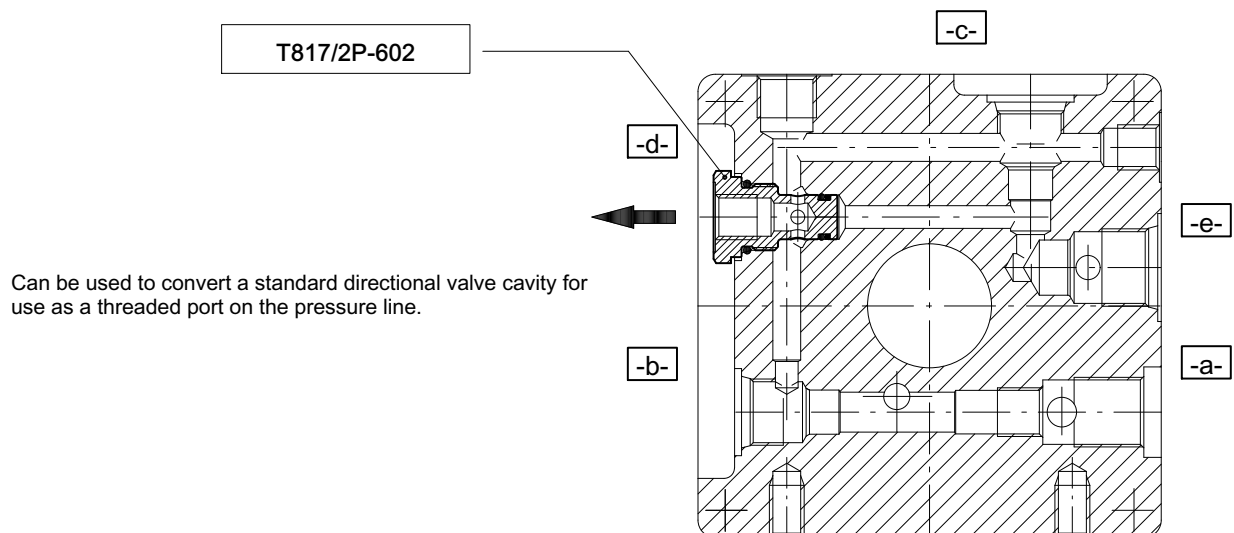
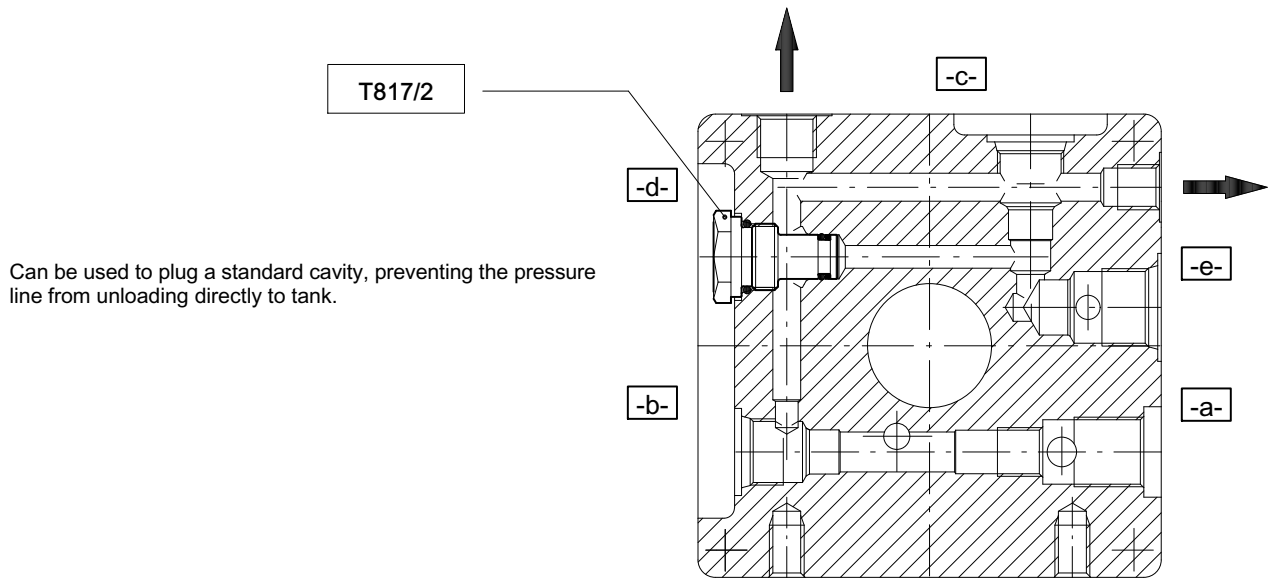

8 Manifolds

8.1 Technical information

Power pack housings K3 and K4 can be connected with manifolds, allowing the assembly of complex circuits in compact and modular solution.

8.1.1 Standard manifolds

The range includes monobloc or sectional manifolds with which to create parallel or series circuits for cartridge type solenoid valves or CETOP R35H design.

Take care to verify the position of the filling plug of the chosen tank avoiding version having interference with the valve block.

8.1.2 Special manifolds

To reduce the dimensions and complexity of the system generally (connecting pipe-lines, etc.) special manifolds can be

designed and manufactured to meet particular requirements.

These fully customized manifolds, complete with valves, will incorporate the required hydraulic circuit in its entirety while meeting the dimensional and positional requirements specified by the customer.

8.1.3 Material

Manifold elements are in extruded aluminium alloy EN AW-6082 (UNI3571), with the exception of the directional control valve interface plates which are cast iron EN 6JL250 (UNI5007).

The O-Rings utilized will be NBR-70sh. unless other types are specifically requested.

8.2 Intermediate plate 2144 for manifolds 5073-5033-5053-2083-2043-2013

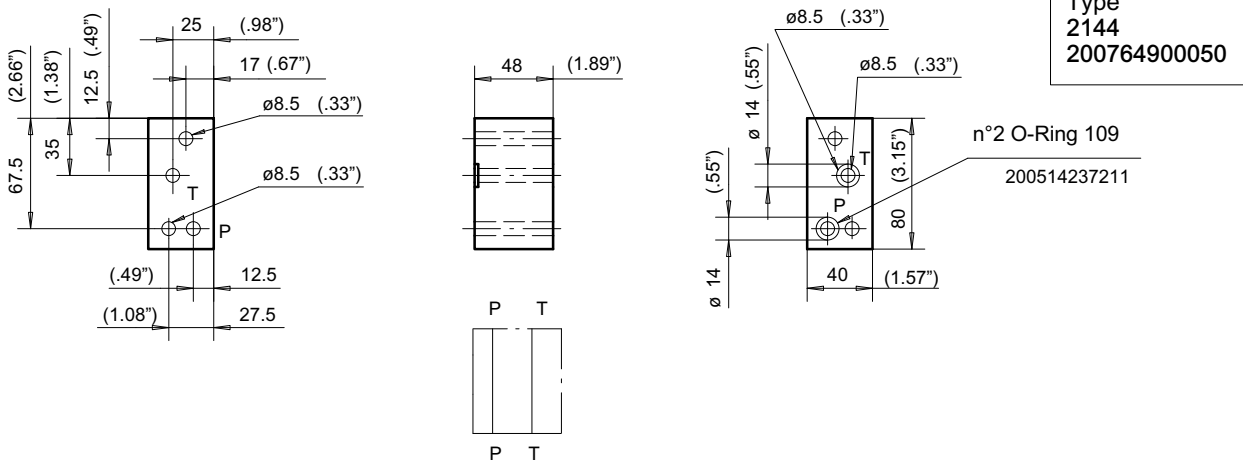

8.3 Parallel circuit - Monobloc manifolds 1-2-3 for solenoid valves DIN24350 FORM A CETOP R35H-ISO4401

A-B ports	3/8" BSP
Port M (plugged)	1/4" BSP

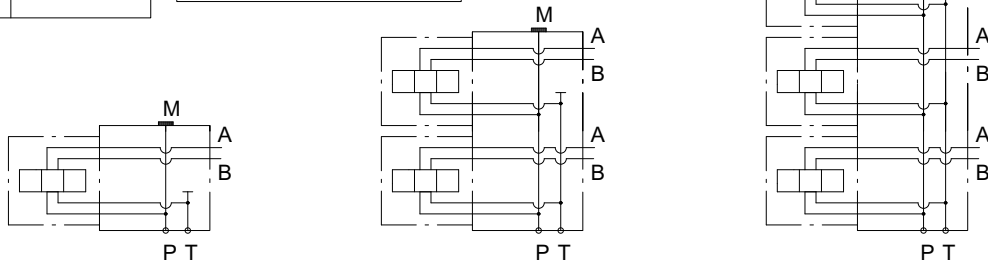
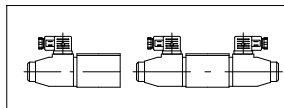

Rear A/B ports : **5073** 200764600030

5033 200764600080

5053 200764601080

Lateral A/B ports : **5173** 200764600020

5133 200764600040

5153 200764600050

* for versions with 4 and more solenoid valves please contact our Sales Department

Type	Manometer port
5073	X = 48 (1,89")
5033	X = 100 (3,94")
5053	X = 152 (5,98")

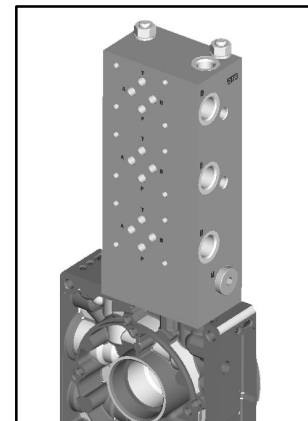
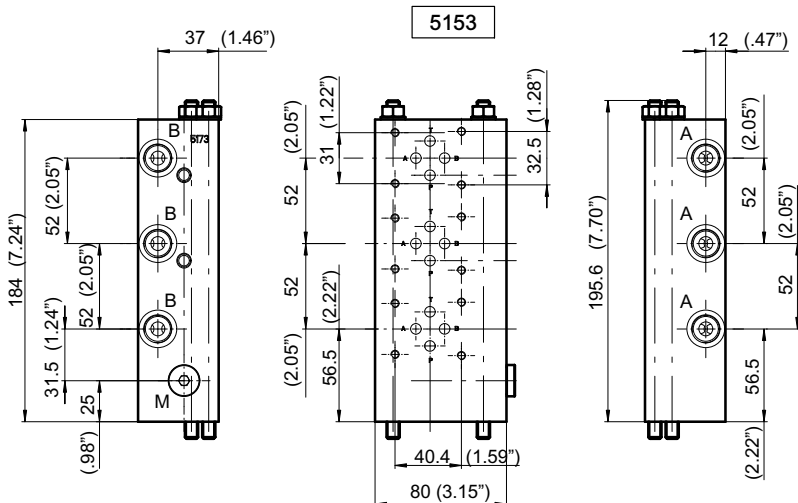
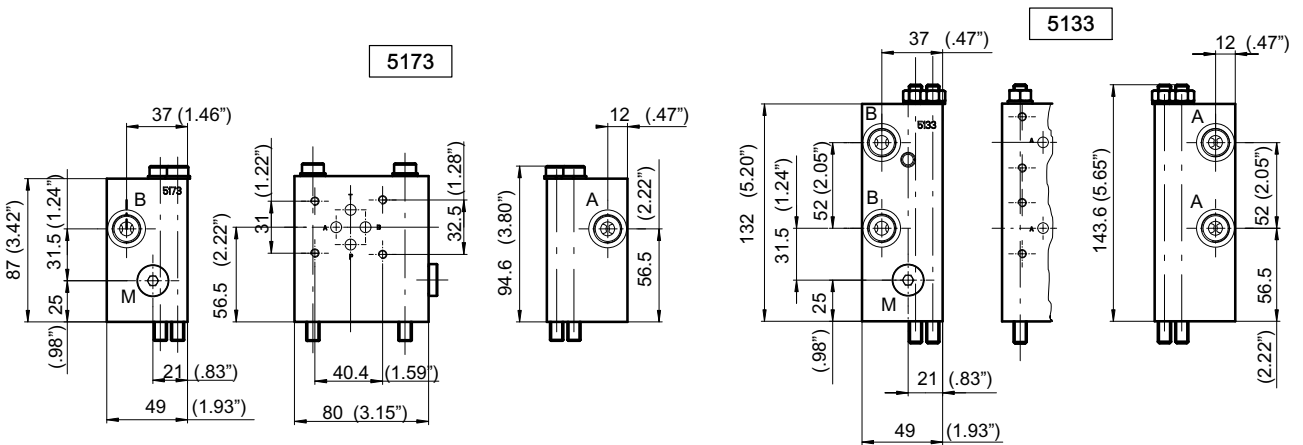
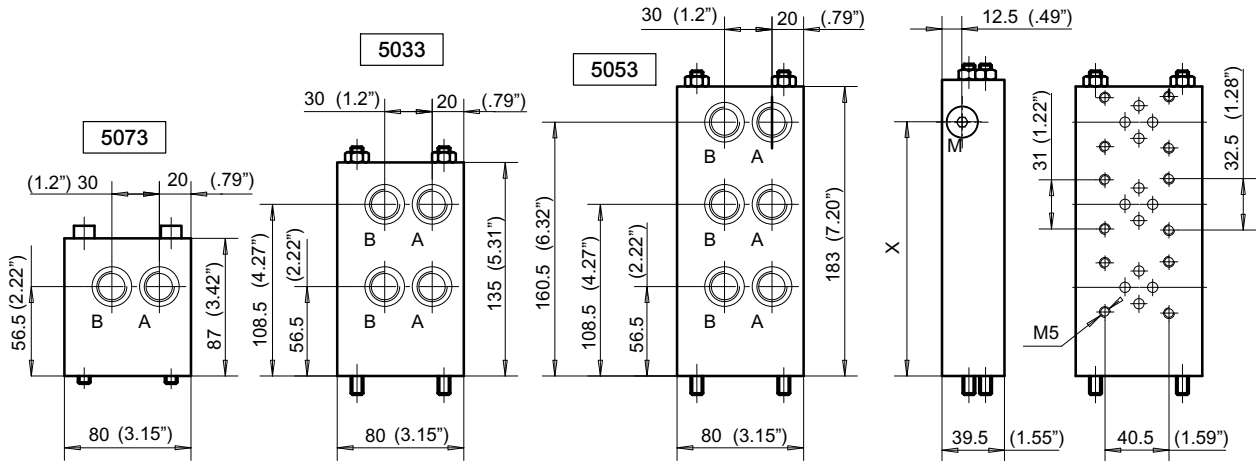
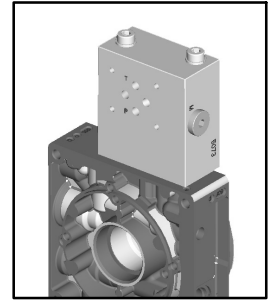
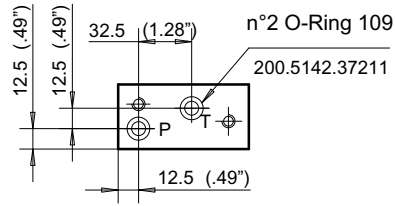

**8.4 Series circuit - Suitable for solenoid valves
DIN24350 FORM A CETOP R35H - ISO4401**

A-B ports	3/8" BSP
Port M (plugged)	1/4" BSP

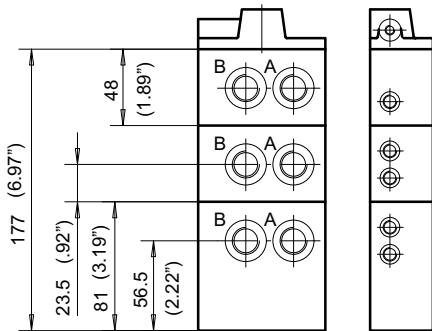
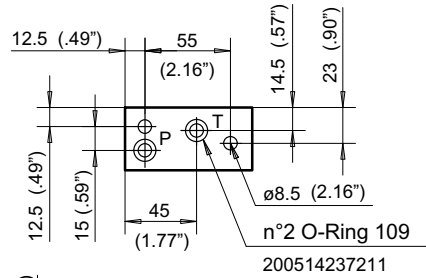
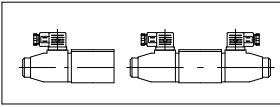

- 4042
200764000040
- 2013
200764400070
- 2043
200764400090
- 2083
200764400100

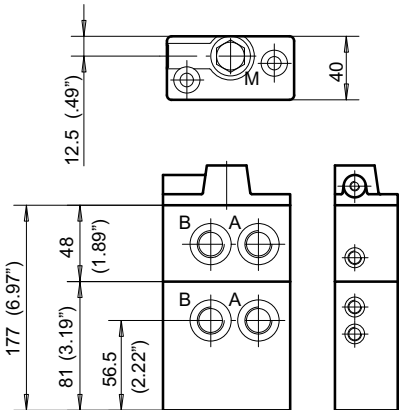
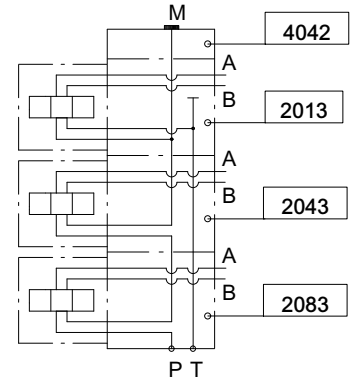
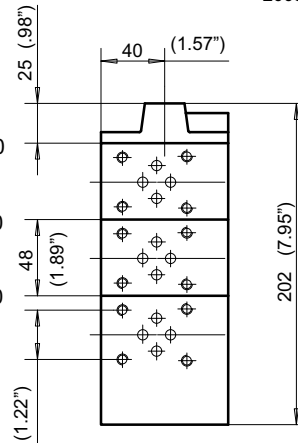

- 4042
- 2013
- 2083

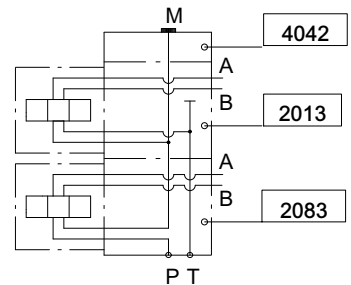
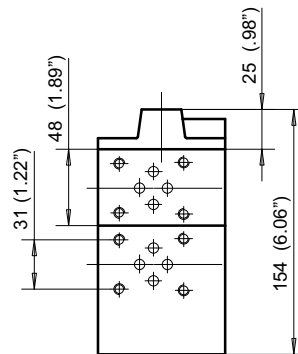

**8.5 Series circuit - Circuit with more than three
solenoid valves DIN24350 FORM A CETOP
R35H - ISO4401**

To obtain a hydraulic circuit with more than 3 solenoid valves (DIN24350 FORM A CETOP R35H - ISO4401) connected together, simply add one or more 2043 type manifolds as required.

The hydraulic diagram shows an arrangement with 4 solenoid valves

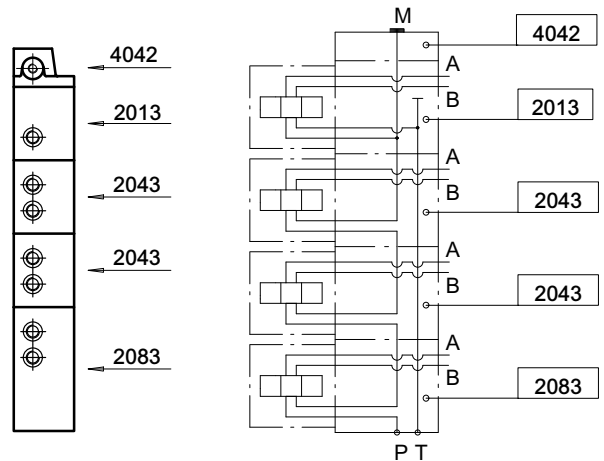

8.6 Spacer plate 4210 for manifolds: 5073-5033-5053-2083-2043-2013 DIN24350
FORM A CETOP R35H-ISO4401

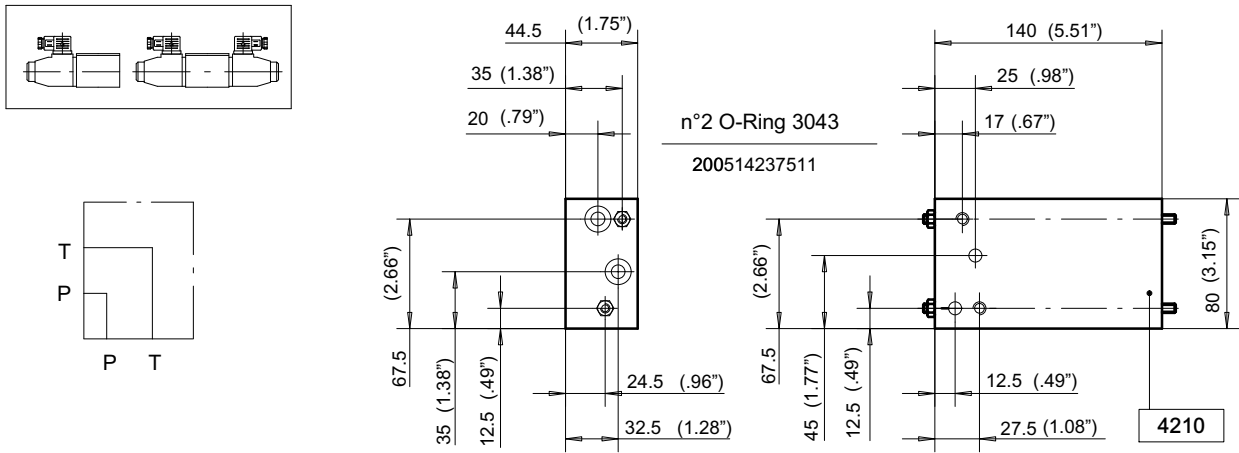

Code: 200764900160

Mounting and ordering examples

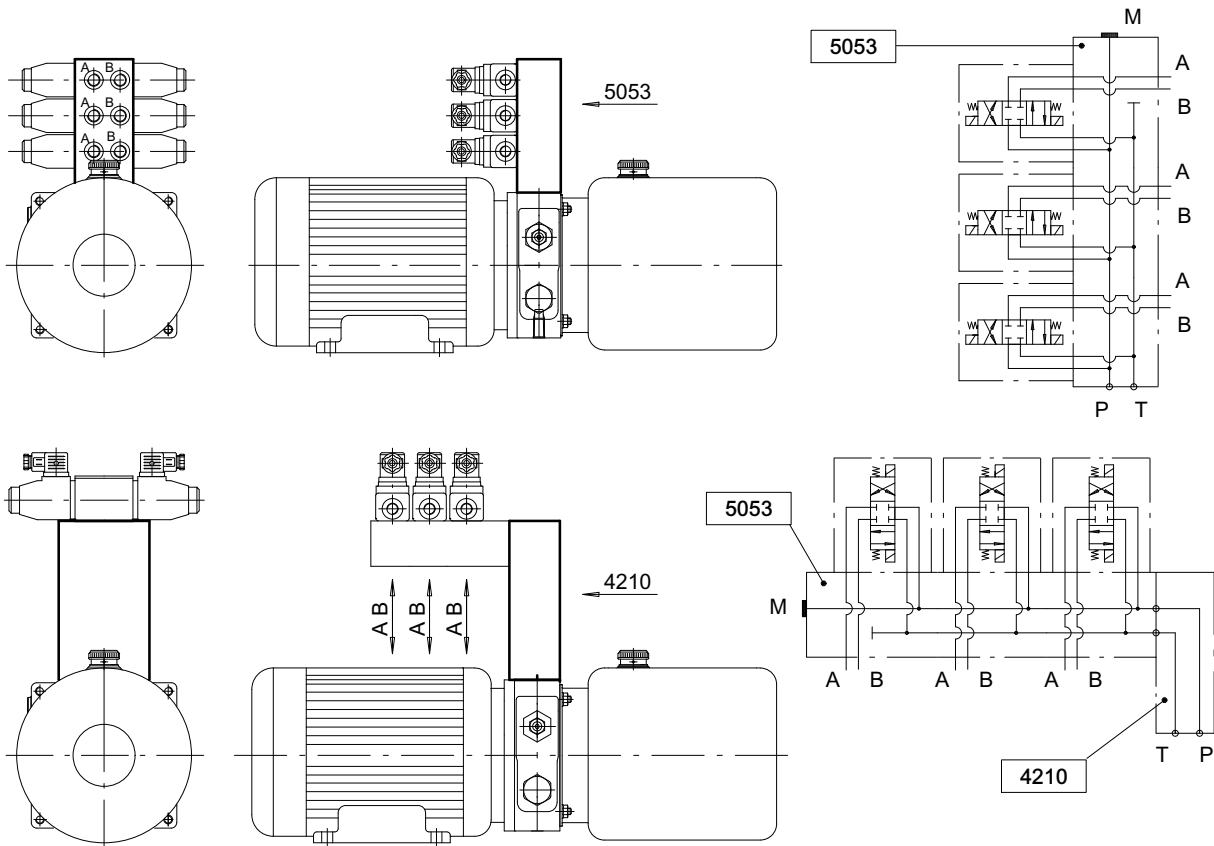

Example

	Sequence	Manifolds	Valves for manifolds	Q.ty	Volt
8	1	4 2 1 0		1	1 3
	2	5 0 5 3	B - 0 2	3	

8.7 Solenoid valves DIN 24350 FORM A CETOP R35H - ISO4401*

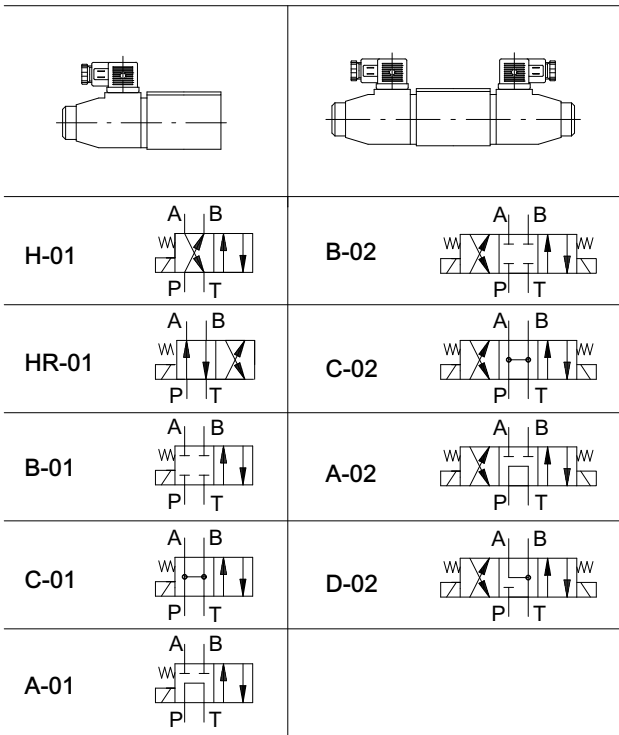

Max. Pressure	210 bar
Max. Flow	25 l/min.
Intermittence	ED = 100%
Voltage tolerance	± 10%
Leakage	15/60 cm ³ /min.
Connector type	DIN 43650

D.C. Coils		A.C. Coils	
Voltage	Type	Voltage	Type
12 V.	13	24 V.	21
24 V.	23	110 V.	41
		220 V.	51

* Please contact our Sales Dept. for hydraulic circuit not indicated

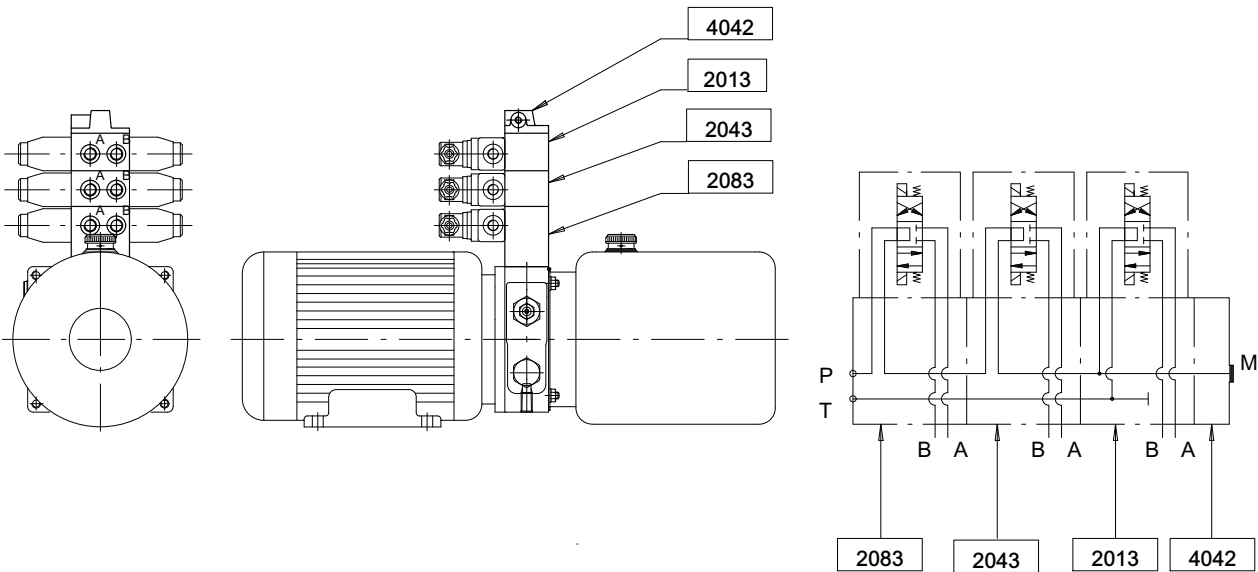

8	Sequence				Manifolds				Valves for manifolds				Q.ty	Volt	
	1	2	3	4	2	0	8	3	A	-	0	2		1	1 3
					2	0	4	3	A	-	0	2		1	
					2	0	1	3	A	-	0	2		1	
					4	0	4	2						1	

8.8 Manifolds with direct thread ports P and T for K3P001 and K4P001 housings

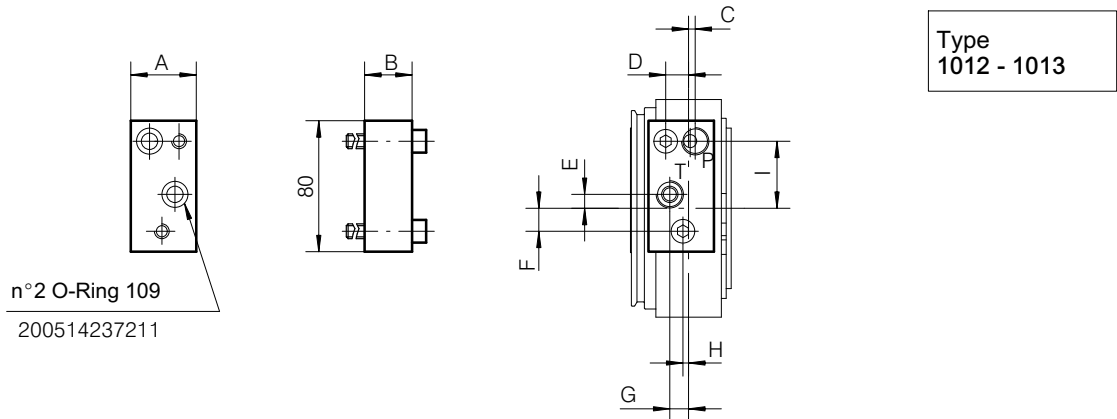

Ø (P/T)	Type	Code	A	B	C	D	E	F	G	H	I
1/4" BSP	1012	200765000620	40	30	3	14	8.5	14	11.5	3.5	41
3/8" BSP	1013	200765000600	40	29	4	14	8.5	14	11.5	3.5	41

8.9 Intermediate manifold for UP100K3P001 Suitable for PM817/1.5 manual pump

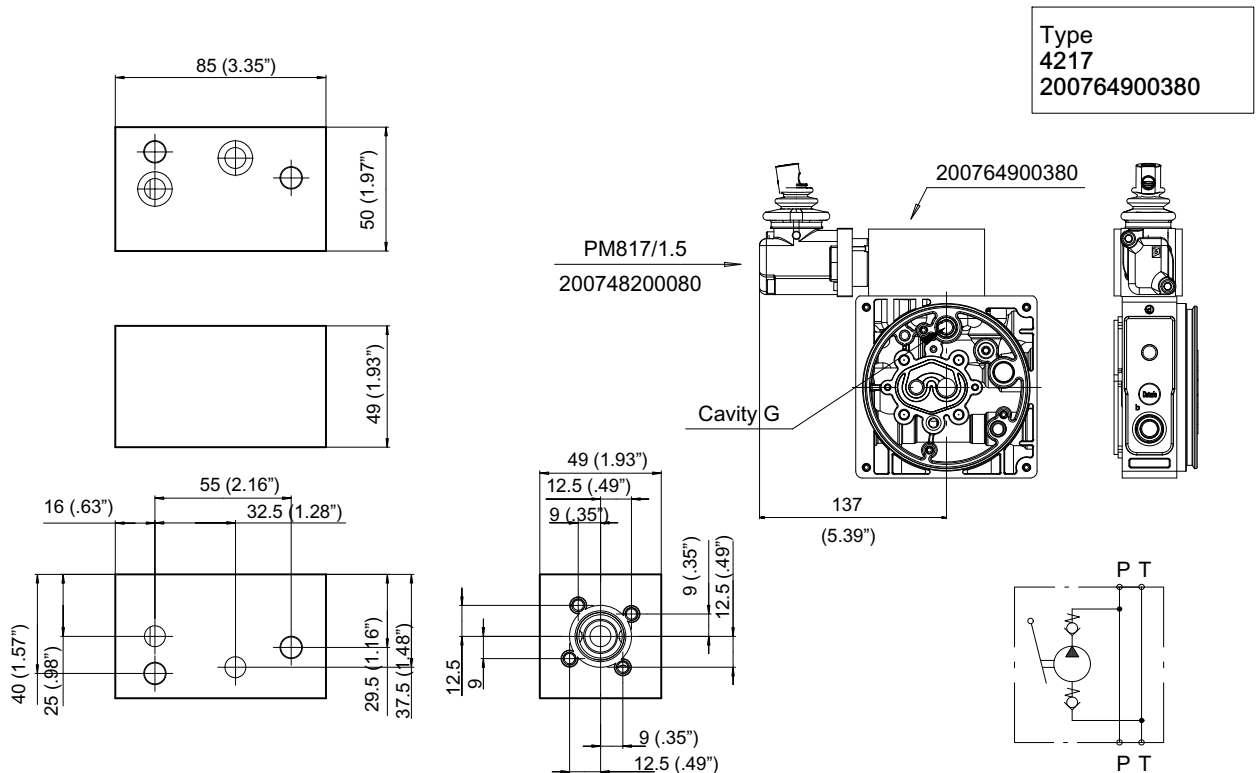

Note: To use the manual pump a suction pipe has to be assembled inside the cavity G (3/8" BSP); the suction pipe length

depends by the tank length. See section 4.3 for special filter conveyer

8.10 Special blocks interface 5203

Allows the assembling of special blocks with alternative interface: 3542 - 3547 - 3552 - 3593, with dedicated hydraulic scheme for

most common applications.

Suitable for special versions of K3 and K4 housing

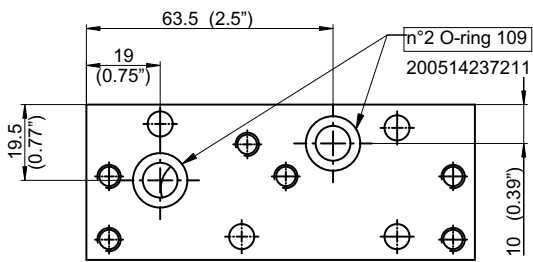
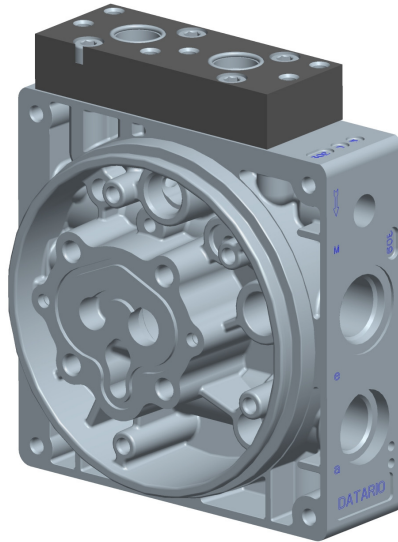

Housing side

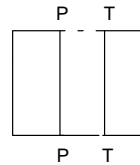

Code
200765000640

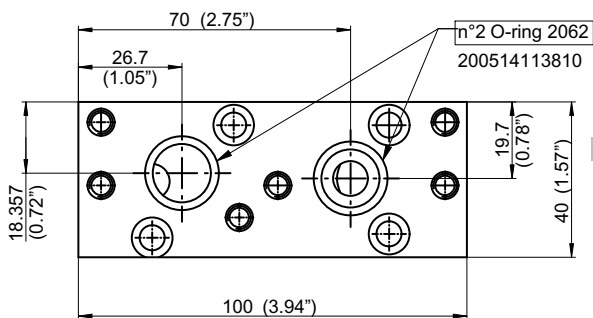
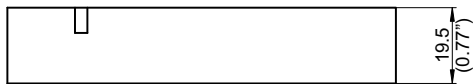

Block side

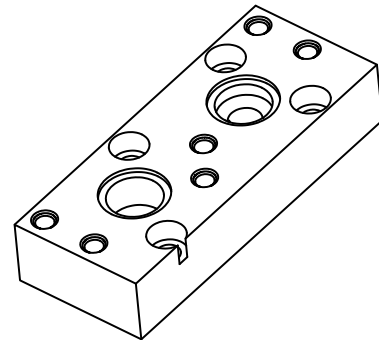

8.11 Manifolds for HDS11-HDS07 directional control valve - Vertical mounting

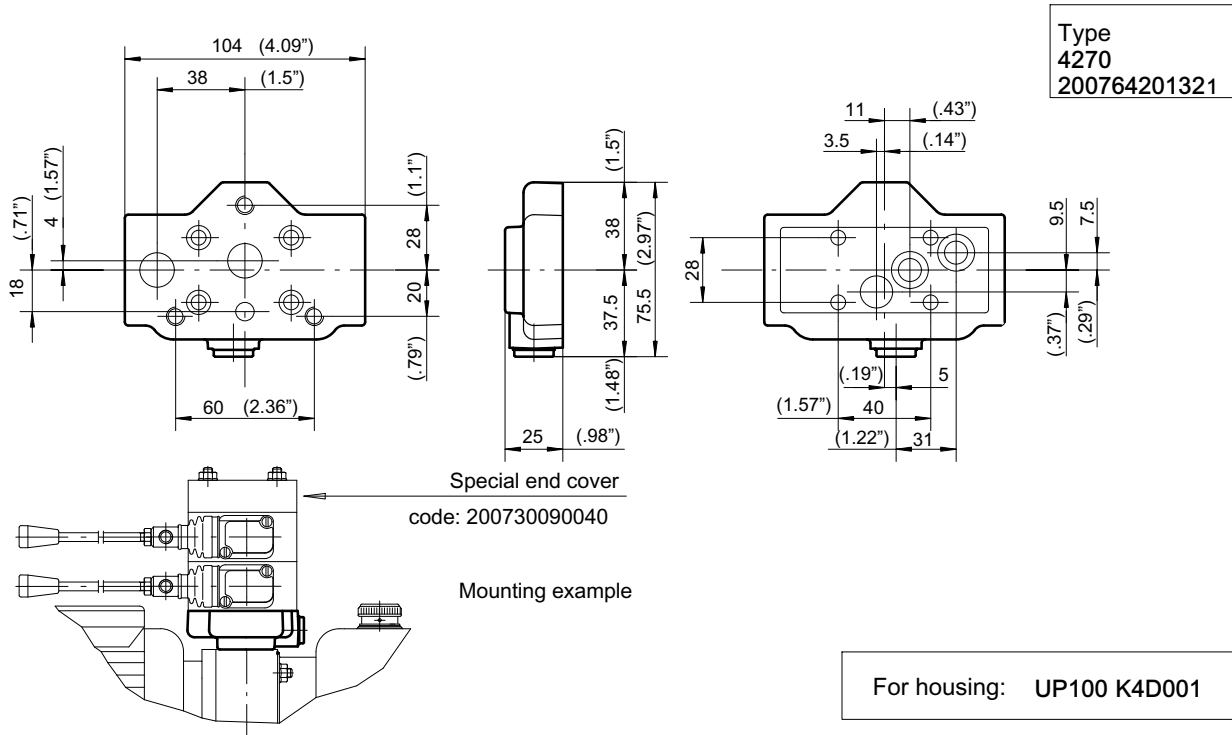

8.12 Manifold for HDS11-HDS07 directional control valve - Horizontal mounting

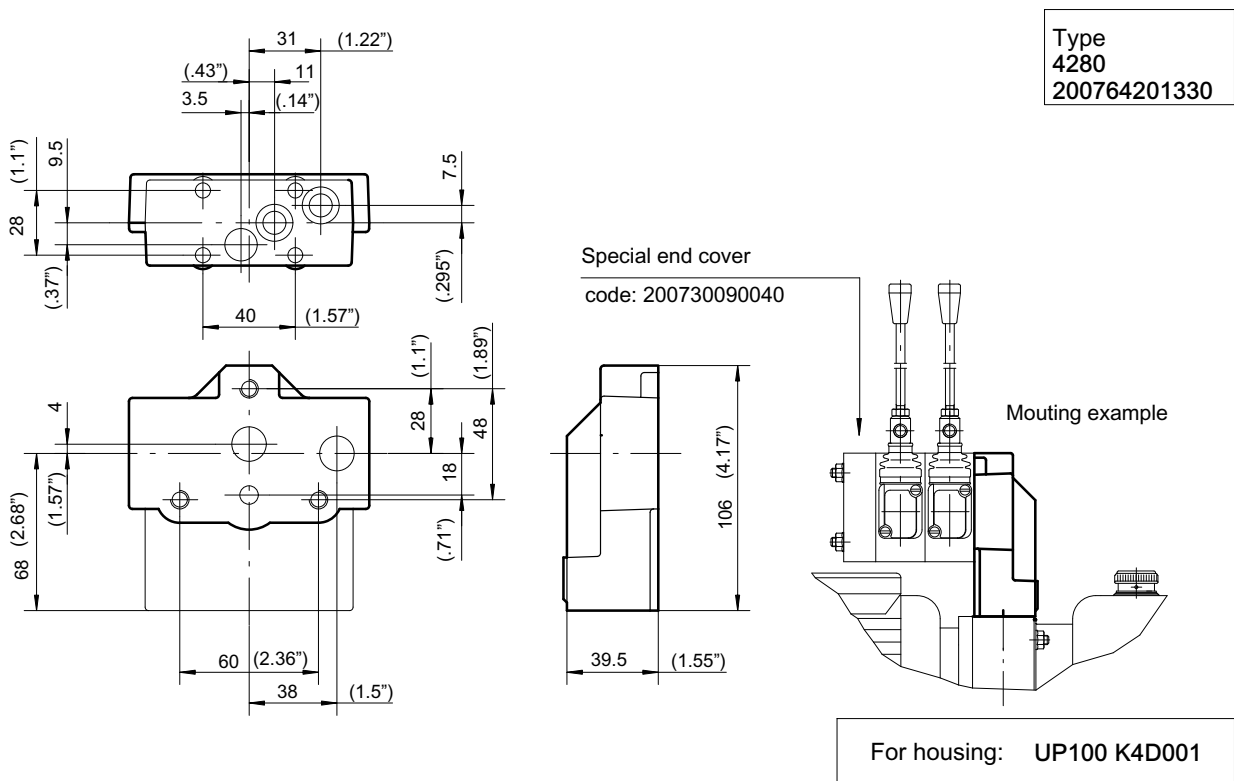

For technical information regarding performance, ordering information and selection, please, refer to the HDS07 and HDS11 section of the Directional control valve catalogue

8.13 Special block 3151

Pre-arranged for 2 x SDR(E)817/22-TS solenoid valve

The block allows to control, singly or together the lifting and lowering function of two single acting cylinders connected to the port A and B. Suitable for housing UP100/K1G2* - UP100/K4G2*. It could be only assembled on K housings main work port A.

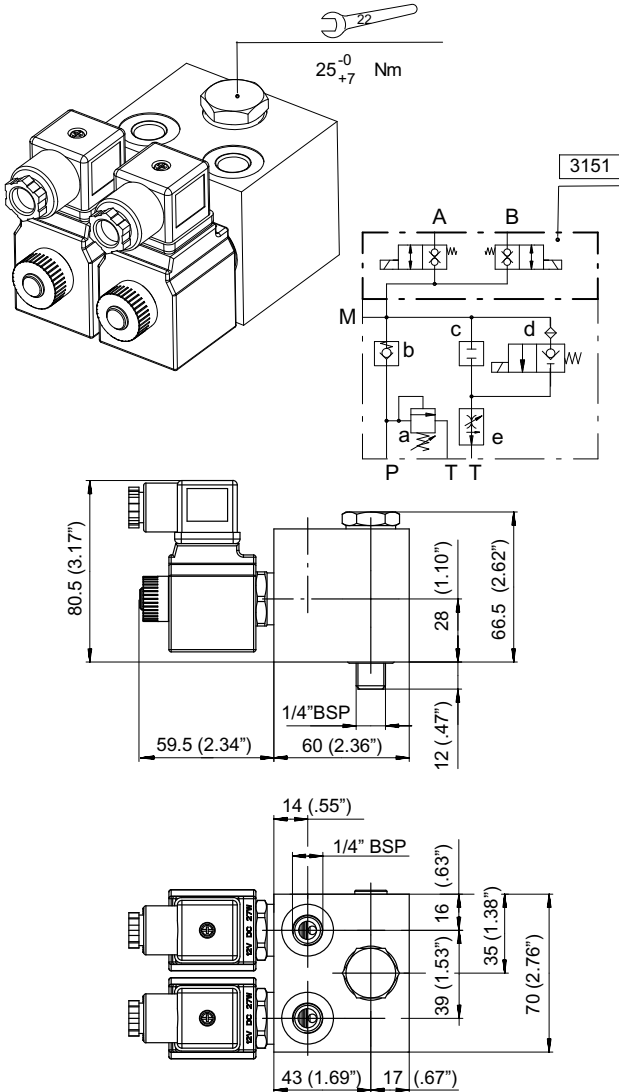

A.C. supply requires connector with bridge rectifier included

SDR(E)817/22-TS Electric performances	
Max. flow (see operating limit at section 7.4.2)	20 l/min.210 bar
Max. pressure	230 bar
Max recommended pressure	210 bar
Rated power	27 Watt
Intermittence	ED= 100%
Voltage tolerance	± 10%
Internal leakage	0-5 drops/min.
Temperature range	-20/+90° C
Connector type	DIN 43650
Time to open (50-210 bar)	15-50 ms.
Time to close (50-210 bar)	15-50 ms.
O-Ring replacement kit	200974200390

Normally closed Poppet type Direct type Bi-directional flow admitted

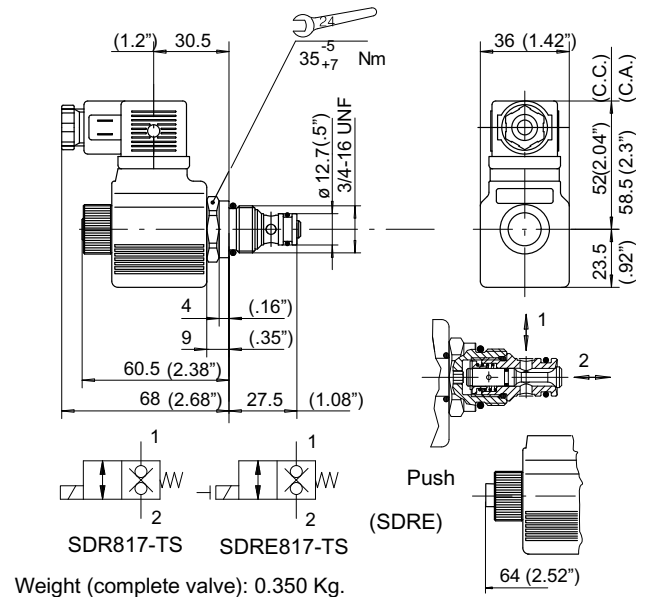

Weight (complete valve): 0.350 Kg.

Ordering code

1/4" BSP Fitting: 200770000660

3151 block without solenoid valve : 200703500230

Directional valve without coil and connector

SDR817/22-TS P.M.	200757200690
SDRE817/22-TS P.M.	200757200730

Coil voltage

Volt	D.C.		A.C.	
	12 V.	24 V.	24 V.	110 V. 220 V.
Type	13	23	21	41 51

Complete solenoid valve for D.C. current

SDR817/22-TS-13-HC	200957010053
SDR817/22-TS-23-HC	200957020054
SDRE817/22-TS-13-HC	200957010055
SDRE817/22-TS-23-HC	200957020056

Complete solenoid valve for A.C. current

SDR817/22-TS-21-HC	200956920040
SDR817/22-TS-41-HC	200956940035
SDR817/22-TS-51-HC	200956960038
SDRE817/22-TS-21-HC	200956920042
SDRE817/22-TS-41-HC	200956940037
SDRE817/22-TS-51-HC	200956960040

Performances of the SDR817 valve, only

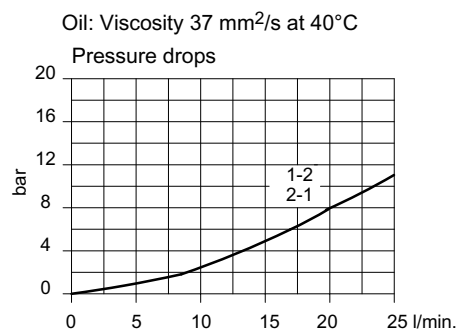

8.14 Special block 3051

Pre-arranged for one SPE817/22-TVR solenoid valve.

Valve block to be used in combination with the PDF817 solenoid proportional control valve in order to assure the load held at its stopped position and control the load speed proportionally, either during the lifting and lowering function. Suitable for housing UP100/K1G2* - UP100/K4G2*.

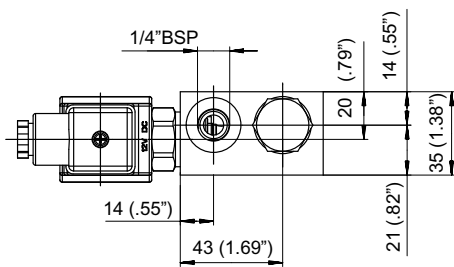
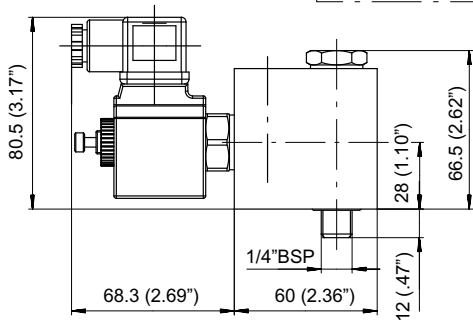
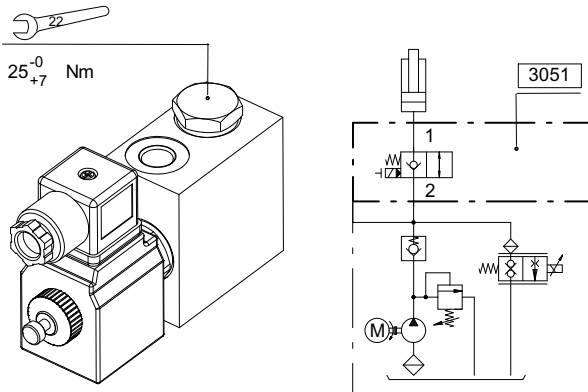

A.C. supply requires connector with bridge rectifier included

SPE817/22-TVR Electric performances

Max. pressure	300 bar
Max. recommended pressure	210 bar
Max. flow	25 l/min.
Rated power	22 Watt
Intermittence	ED= 100%
Voltage tolerance	± 10%
Internal leakage	0-5 drops/min.
Temperature range	-20/+90° C
Connector type	DIN 43650
Time to open (50-210 bar)	15-60 ms.
Time to close (50-210 bar)	15-60 ms.
O-Ring replacement kit	200974200140

200 - P - 991214 - E - 13/03.13
UP100

Normally closed Pilot type
Poppet type, bi-directional flow admitted, without filter

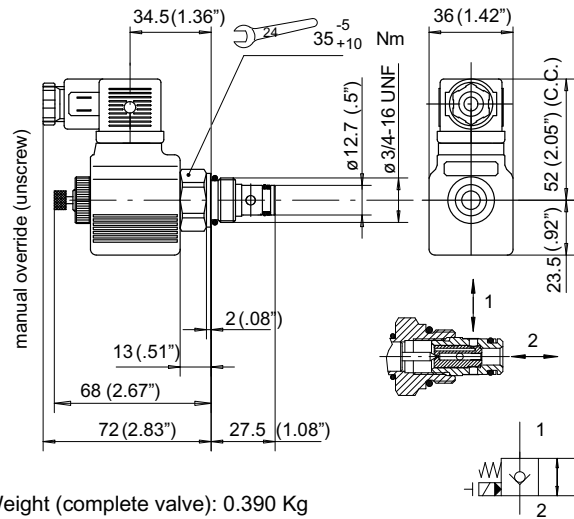

Weight (complete valve): 0.390 Kg

Ordering code

1/4" BSP Fitting: 200770000660

3051 block without solenoid valve: 200703500260

Directional valve without coil and connector

SPE817/22-TVR P.M.	200757200770
--------------------	--------------

Coil voltage

Volt	D.C.		A.C.		
	12 V.	24 V.	24 V.	110 V.	220 V.
Type	13	23	21	41	51

Complete solenoid valve for D.C. current

SPE817/22-TVR-13-HC	200957010046
SPE817/22-TVR-23-HC	200957020048

Complete solenoid valve for A.C. current

SPE817/22-TVR-21-HC	200956920037
SPE817/22-TVR-41-HC	200956940032
SPE817/22-TVR-51-HC	200956960035

Performances of the SPE valve, only

Oil: Viscosity 37 mm²/s at 40 °C

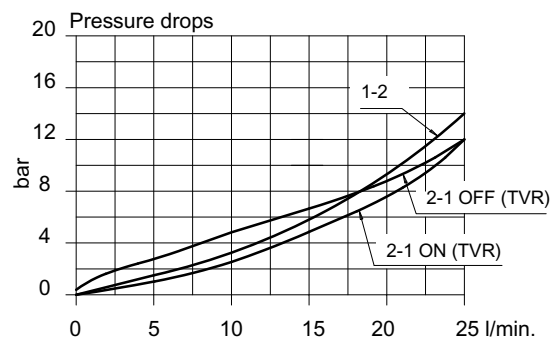

Minimum operating pressure= 5 bar

8.15 Special block 3152

Pre-arranged for one SDR(E)817/22-TS solenoid valve.

Valve block able to control and operate two single acting cylinders with the possibility to balance both at the same level operating the solenoid control valve.
Suitable for housing UP100/K1G2* - UP100/K4G2*.

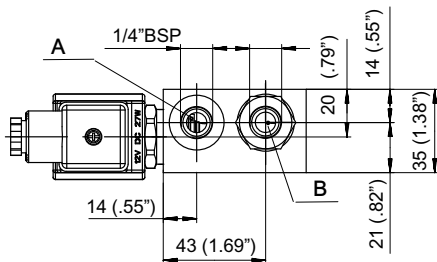
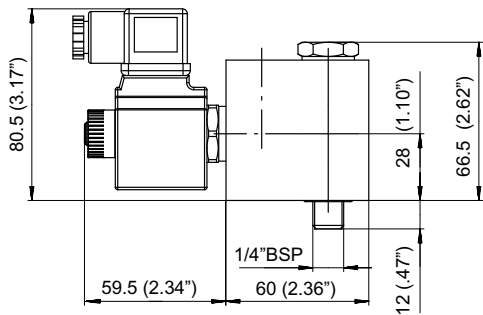
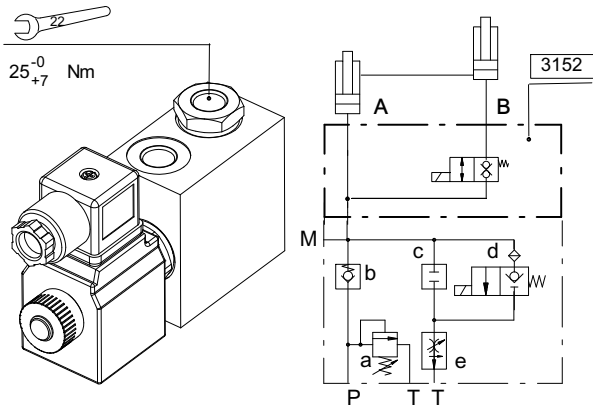

A.C. supply requires connector with bridge rectifier included

SDR(E)817/22-TS Electric performances	
Max. flow (see operating limit at section 7.4.2)	20 l/min.210 bar
Max. pressure	230 bar
Max recommended pressure	210 bar
Rated power	27 Watt
Intermittence	ED= 100%
Voltage tolerance	±10%
Internal leakage	0-5 drops/min.
Temperature range	-20/+90° C
Connector type	DIN 43650
Time to open (50-210 bar)	15-50 ms.
Time to close (50-210 bar)	15-50 ms.
O-Ring replacement kit	200974200390

Normally closed
Poppet type

Direct type
Bi-directional flow admitted

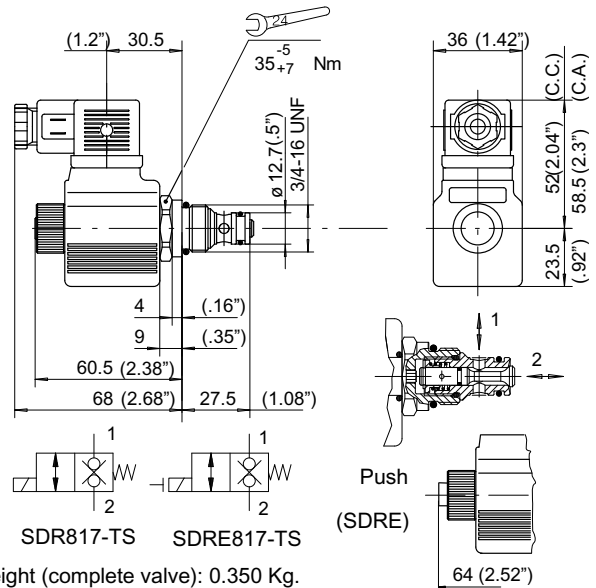

Weight (complete valve): 0.350 Kg.

Ordering code

1/4" BSP Fitting: 200770000800

3152 block without solenoid valve: 200703500280

Directional valve without coil and connector

SDR817/22-TS P.M.	200757200690
SDRE817/22-TS P.M.	200757200730

Coil voltage

Volt	D.C.		A.C.		
	12 V.	24 V.	24 V.	110 V.	220 V.
Type	13	23	21	41	51

Complete solenoid valve for D.C. current

SDR817/22-TS-13-HC	200957010053
SDR817/22-TS-23-HC	200957020054
SDRE817/22-TS-13-HC	200957010055
SDRE817/22-TS-23-HC	200957020056

Complete solenoid valve for A.C. current

SDR817/22-TS-21-HC	200956920040
SDR817/22-TS-41-HC	200956940035
SDR817/22-TS-51-HC	200956960038
SDRE817/22-TS-21-HC	200956920042
SDRE817/22-TS-41-HC	200956940037
SDRE817/22-TS-51-HC	200956960040

Performances of the SDR817 valve, only

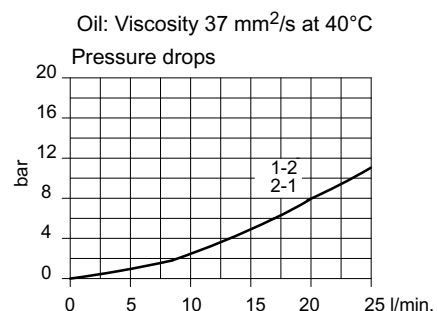

8.16 Special block 5200

Pre-arranged for 1 for 3/2 poppet type solenoid valve.
 Valve block able to control and operate two single acting cylinders independently.
 Typical system for Tail Gates
 Suitable for housing K4-P0*.

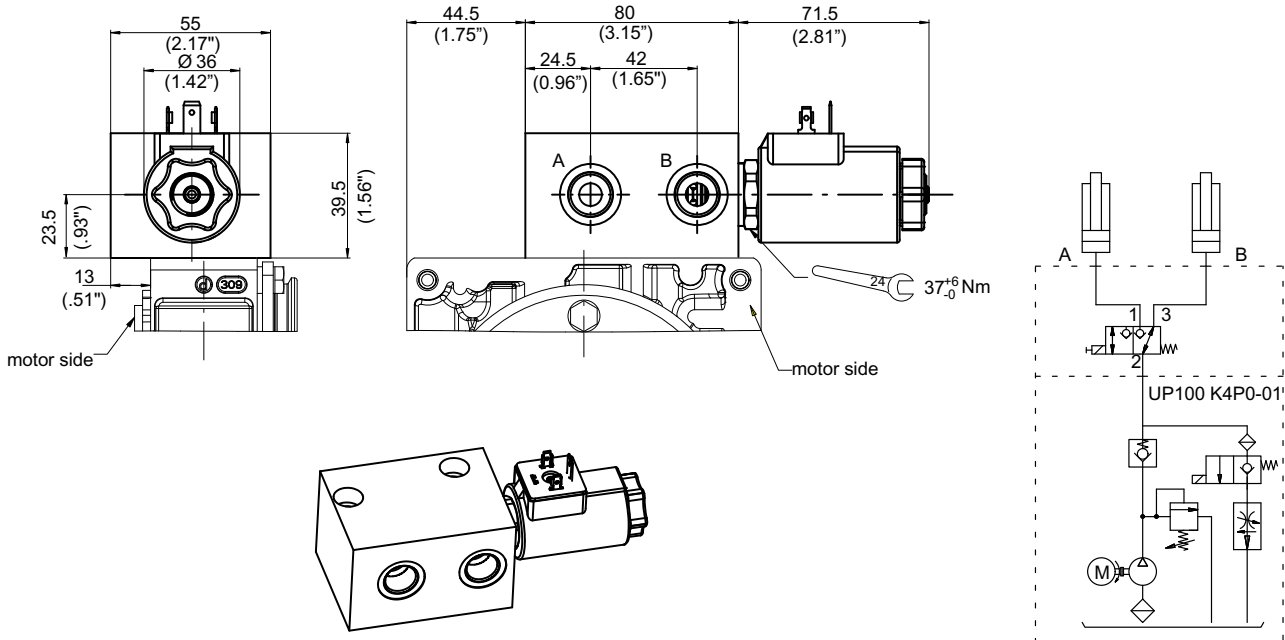

3/2 Solenoid Cartridge valve—Electric performances

Type	3/2 way solenoid directional valve
Design	Direct acting, seat type
Mounting method	Screw in cartridge
Nominal size	5 mm
Mass	0.38 Kg
Mounting attitude	unrestricted
Operating pressure	250 bar
Flow rate Q max.	22 l/min
Fluids (Hydraulic oils HL and HLP)	DIN 51 524
Fluid temperature range	-25/+80° C
Ambient temperature range	-25/+50° C
Viscosity range :	10...500 cSt
recommended	15...250 cst
Minimum fluid cleanliness	18/14 to ISO 4406/CETOP RP70H 8...9 to NAS 1638
Standard voltage	115, 230 50..60HZ VAC 12, 24 VDC
Duty cycle	100 % energisation
Complete block 24 V ordering code	200764601340*

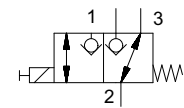

Pressure drops (cartridge only)

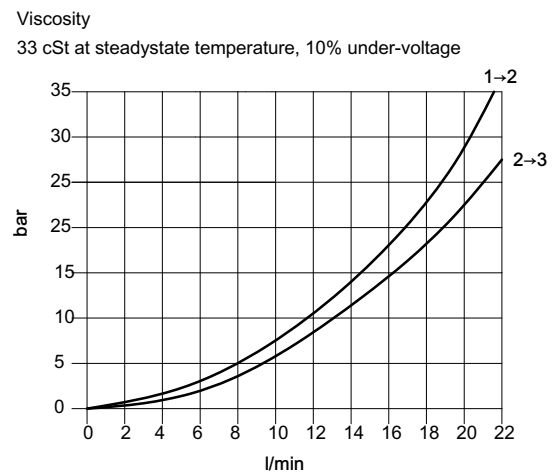

* For other voltages please consult Bucher Hydraulics

8.17 Special block 5201

Pre-arranged for a cartridge flow divider and 2/2 solenoid valves.

Typical system for Car lifter application.

Optional hand pump available between housing and block instead of a spacer.

Suitable for UP100K4-P0* housing

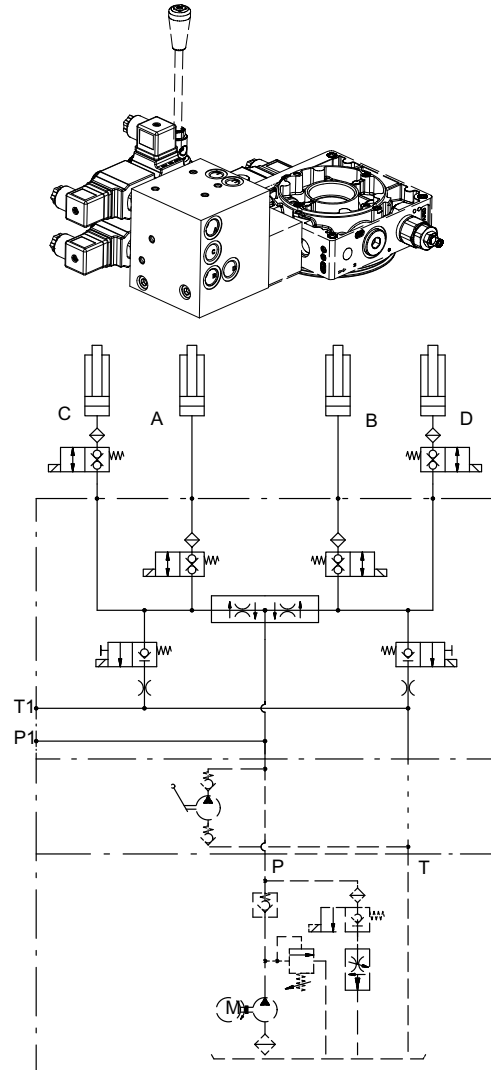
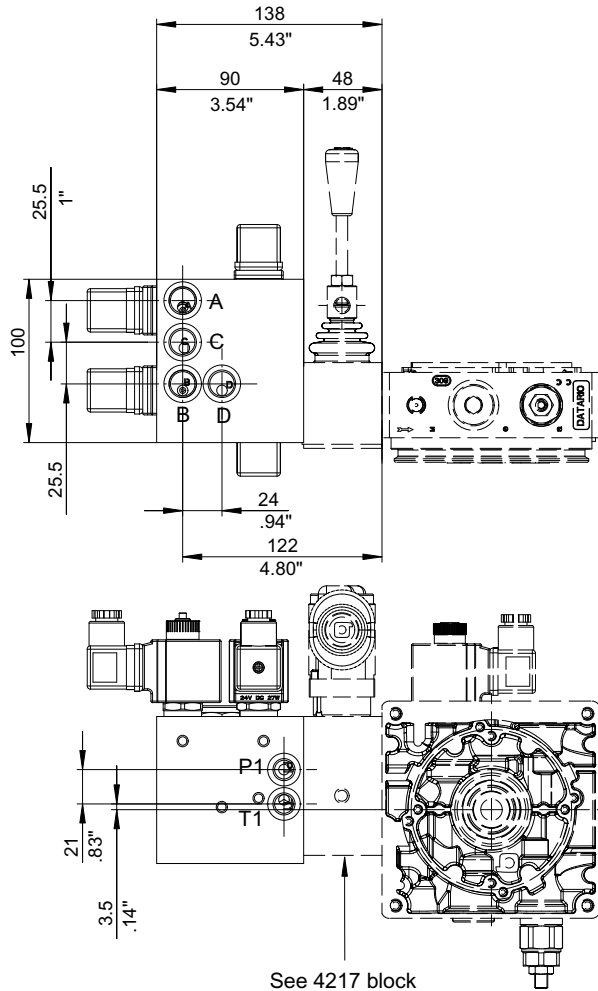

Hydraulic performances

Operating pressure	300 bar
Flow rate Q max.	15 l/min
Port size: A-B-C-D P1-T1	3/8" BSPP 1/4" BSPP
Complete block ordering code (without solenoids and hand pump interface)	200764601350

Note: For solenoids features see section 7.4.6

8.18 Special block 3542

Description

- 1 x 4/2 solenoid cartridge valve located externally. Manifolded directly to the unit.
- Externally adjustable relief valve in C2 port
- #6 SAE outlet

Options

- Pressure compensated (cartridge style) flow control in C1 port
- Motor up

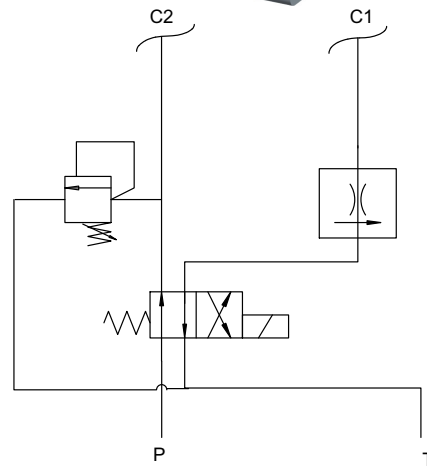
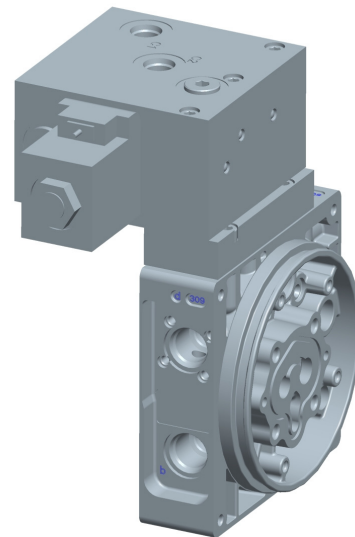
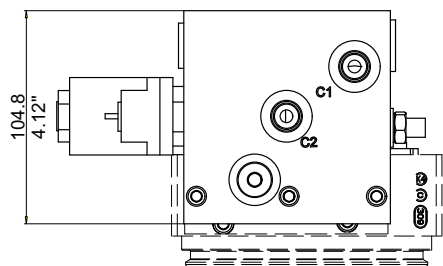
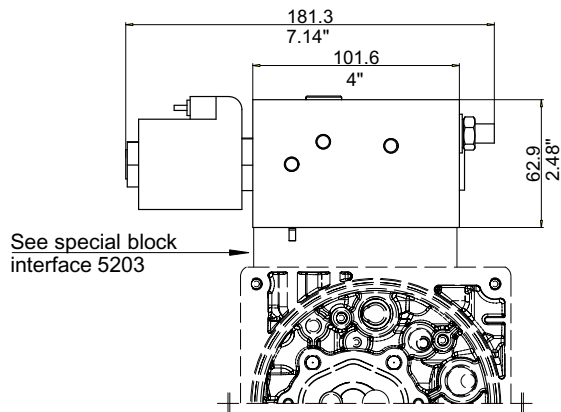

Consult Bucher Hydraulics for additional options and specifications

8.19 Special block 3547

Description

- 2 x 2/2 and 2 x 3/2 solenoid operated cartridge valves located externally and manifolded directly to power unit. Circuit operates one double acting cylinder with both ports positively checked.
- Externally adjustable relief valve
- #6 SAE outlet
- Horizontal mounting standard

Options

- Unit may be wired to independently operate 2 x single acting cylinders.

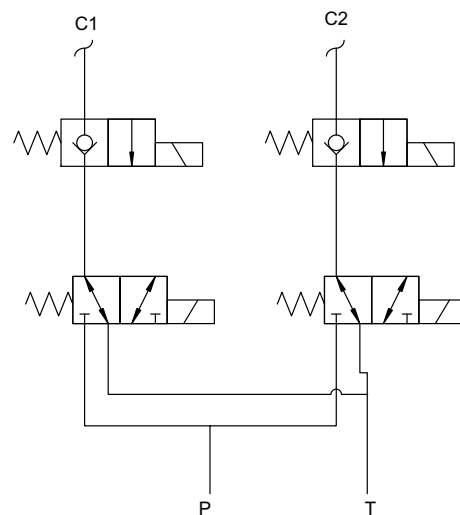
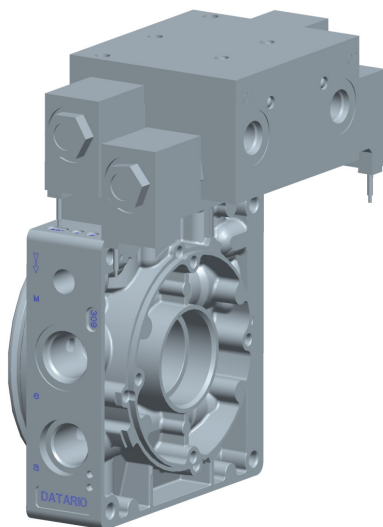
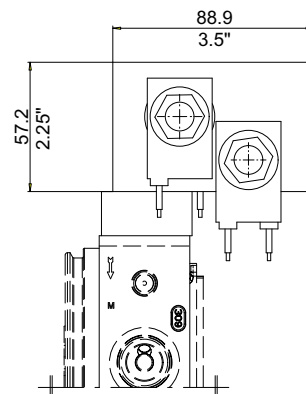
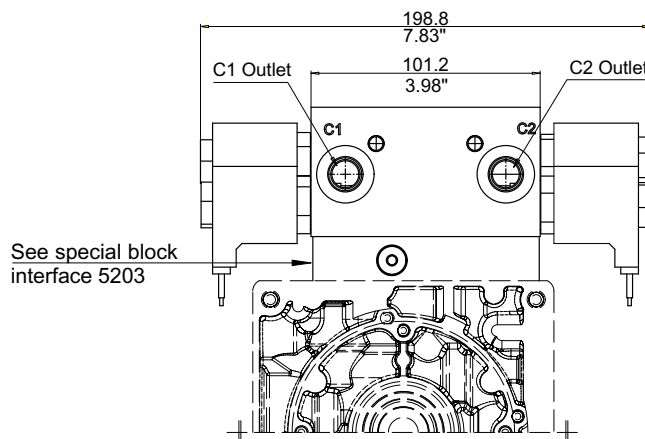

Consult Bucher Hydraulics for additional options and specifications

8.20 Special block 3552

Description

- 1 x 4/2 solenoid cartridge valve and 1 x 2/2 solenoid cartridge valve located externally. Manifolded directly to unit.
- C1 port positively checked
- Externally adjustable relief valve in C2 port
- #6 SAE outlet

Options

- Pressure compensated (cartridge style) flow control in C1 port

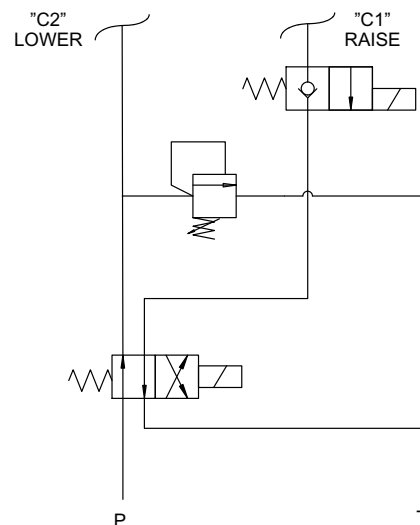
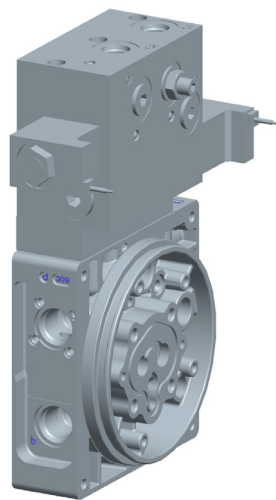
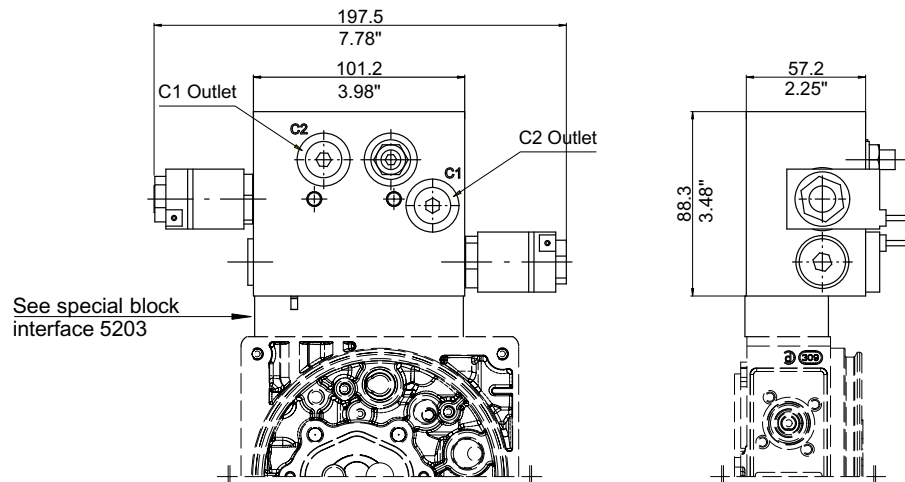

Consult Bucher Hydraulics for additional options and specifications

8.21 Special block 3593

Description

- Solenoid cartridge valves, pilot operated check valves and adjustable cross-over relief system mounted in a compact manifold
- Ideal system for operating a Snow plow. Power up, hold, gravity down, left, right.

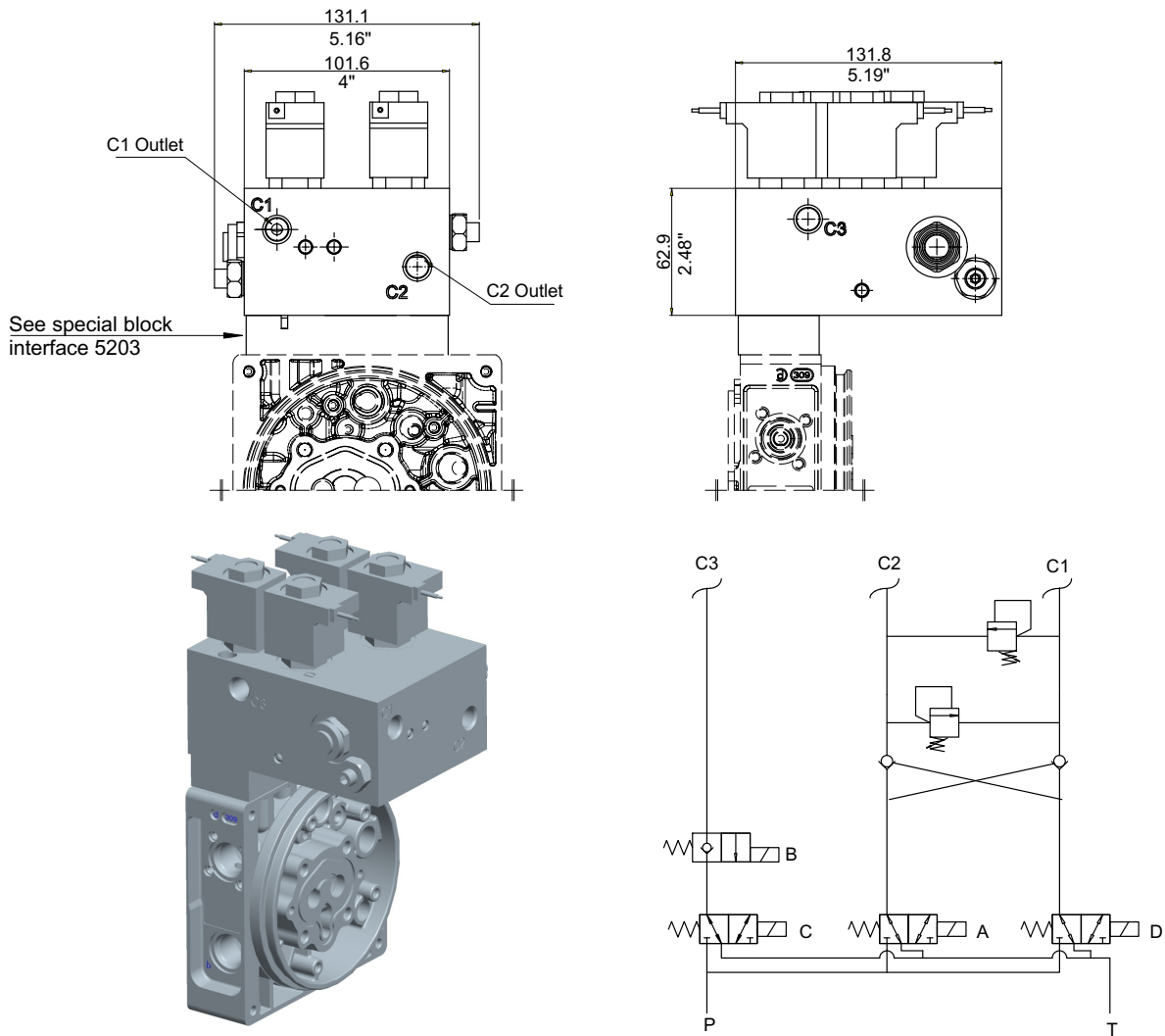

Consult Bucher Hydraulics for additional options and specifications

8.22 Special block 4560

Description

- Ideal system for operating a Dock Leveller.
- #6 SAE outlet

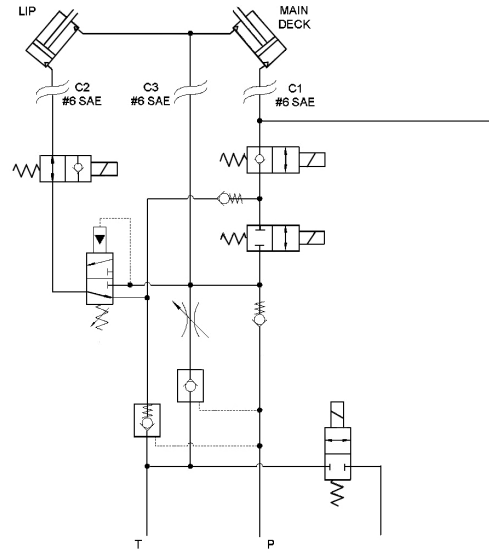
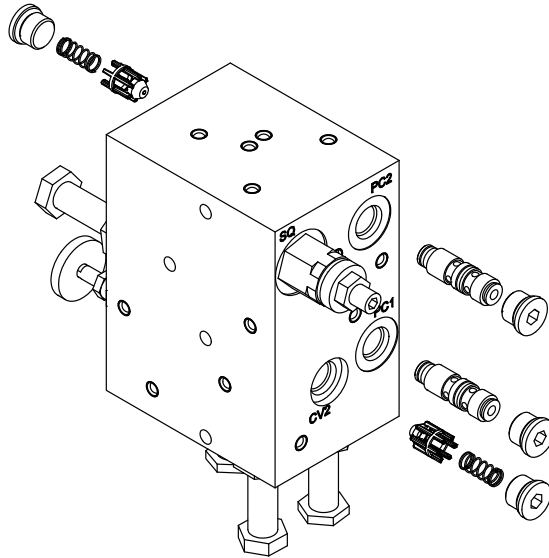

Consult Bucher Hydraulics for additional options and specifications

9 Directional control valves

9.1 Introduction

This chapter illustrates single monobloc directional valves assembled directly on power pack housings UP100K4D002.

The range includes directional control valves for single and double acting circuits, with or without mechanically released detent on the main work port.

9.2 Directional control valve HD105

Single acting

Close centre

Mechanical piloted check valve

Max. pressure	210 bar
Max. flow	20 l/min.
Max. back pressure	30 bar

For housing type:
UP100 K4D002

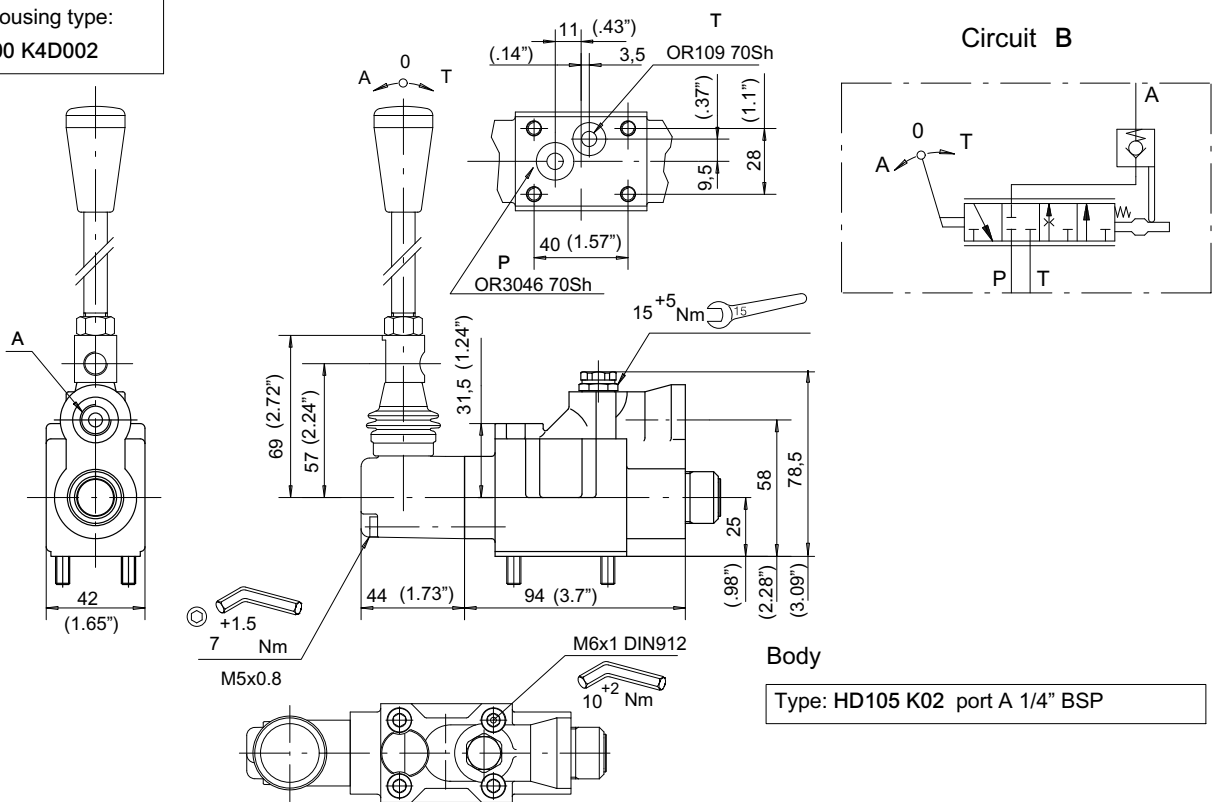

El. n.	Sectional valve body	Circuit	Pos.	Hand lever	Lever stick	Valves for sect. valve
9	1	H D 1 0 5	K 0 2	B		

Performances (Viscosity 37 mm²/s at 40° C)

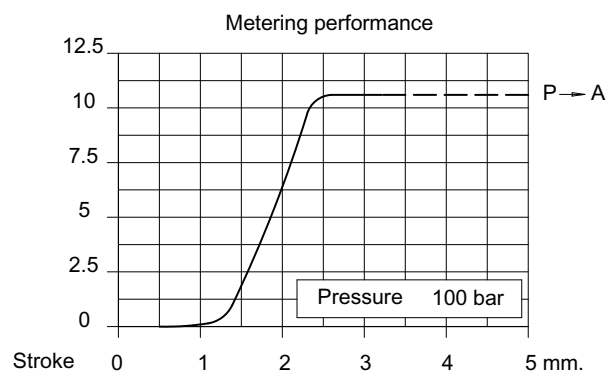
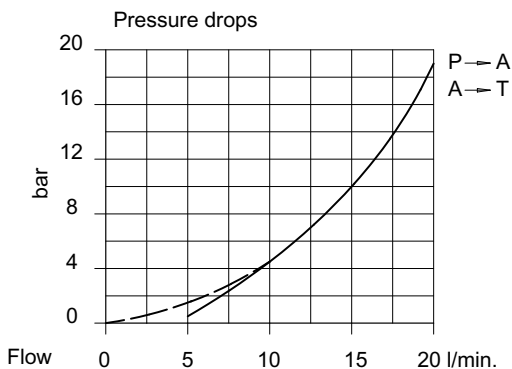

9.2.1 Spool positioner

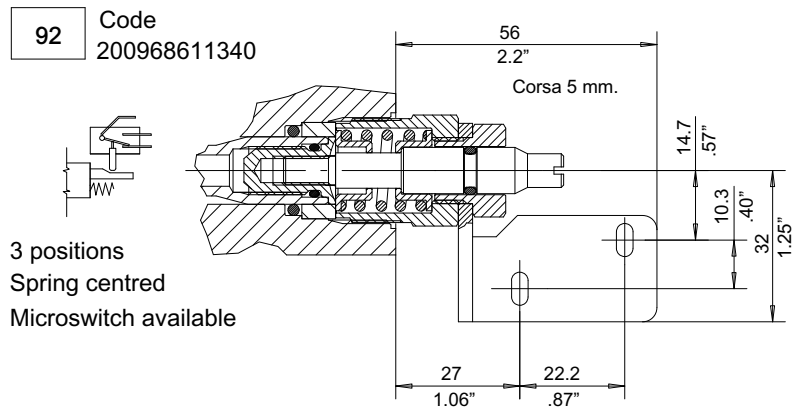
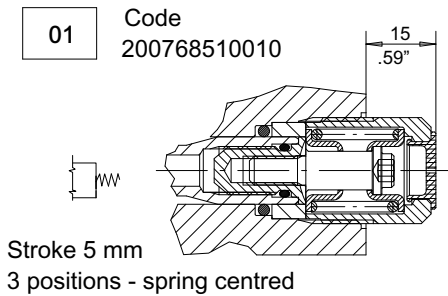

9	El. n.	Sectional valve body	Circuit	Posit.	Hand lever	Lever stick	Valves for sect. valve
1		H D 1 0 5	K 0 2	B	0 1		

9.2.2 Hand lever

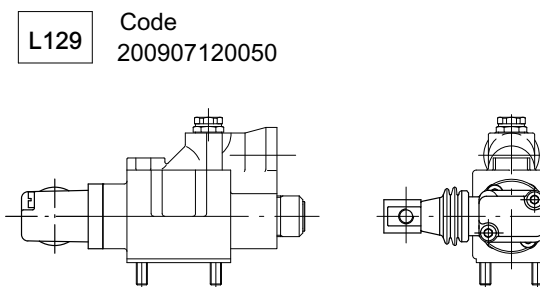
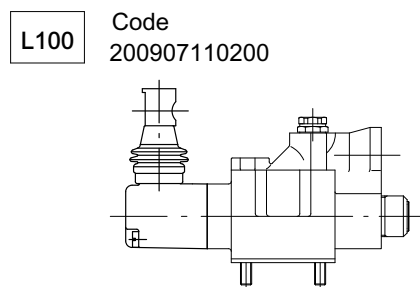

9	El. n.	Sectional valve body	Circuit	Posit.	Hand lever	Lever stick	Valves for sect. valve
1		H D 1 0 5	K 0 2	B	0 1	L 1 0 0	

9.2.3 Lever stick

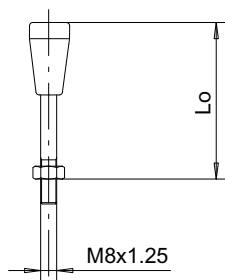

L ₀ Length	Type	Code
150 mm - 5.90 inches	AL001	200702210190
200 mm - 7.87 inches	AL002	200702210030
250 mm - 9.84 inches	AL003	200702210050
300 mm - 11.80 inches	AL004	200702210060

9	El. n.	Sectional valve body	Circuit	Posit.	Hand lever	Lever stick	Valves for sect. valve
1		H D 1 0 5	K 0 2	B	0 1	L 1 0 0	A L 0 0 1

9.2.4 Preassembly code

Directional control valves

HD105-K02-B-01-L100 Code: 200050519019

HD105-K02-B-92-L100 Code: 200050519016

Mechanical piloted check valve

Code: 200987603210

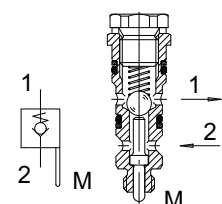

For further information and options, see directional control valves catalogue chapter HDM140

9.3 Directional control valve HD106

Double acting
Close centre
Mechanical piloted check valve

Max. Pressure	210 bar
Max. Flow	20 l/min.
Max. Back pressure	30 bar

For housing type:
UP100 K4D002

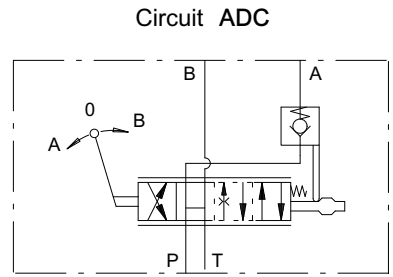
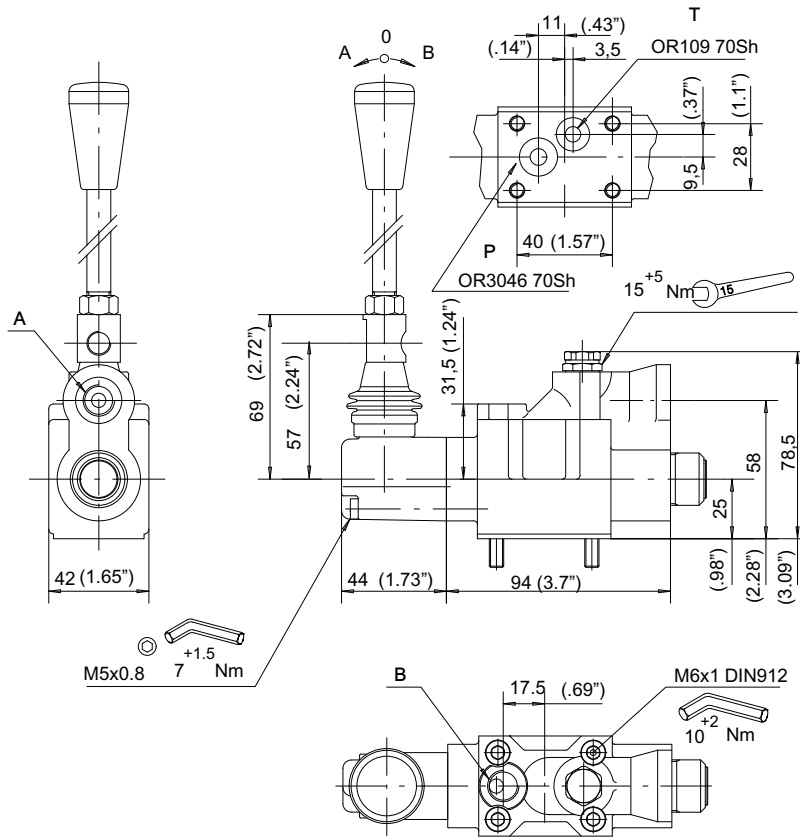

Body
Type: HD106 KN22 black painted
A port 1/4" BSP
B port 1/4" BSP

El. n.	Sectional valve body	Circuit	Pos.	Hand lever	Lever stick	Valves for sect. valve
9	1	H D 1 0 6	K N 2 2	A D C		

Performances (Viscosity 37 mm²/s at 40° C)

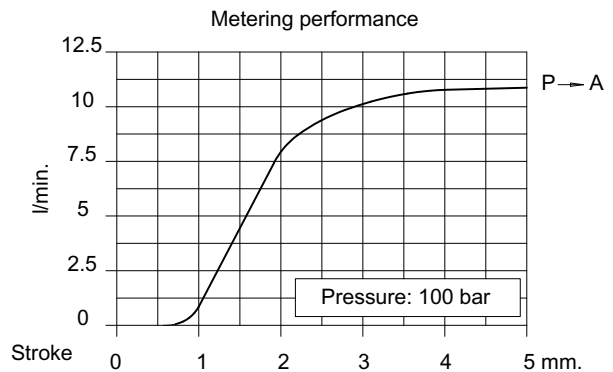
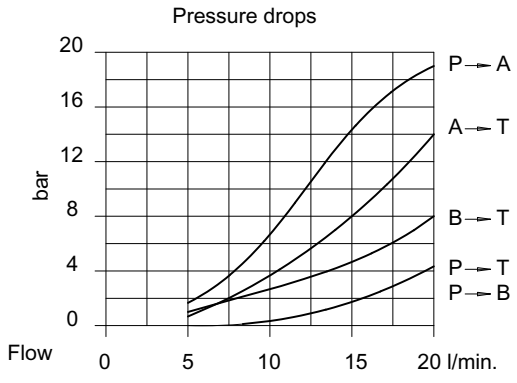

9.3.1 Positioner

01 Code
200768510010

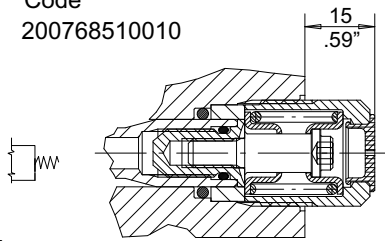

Stroke 5 mm
3 positions
spring centred

34 Code
200968610640

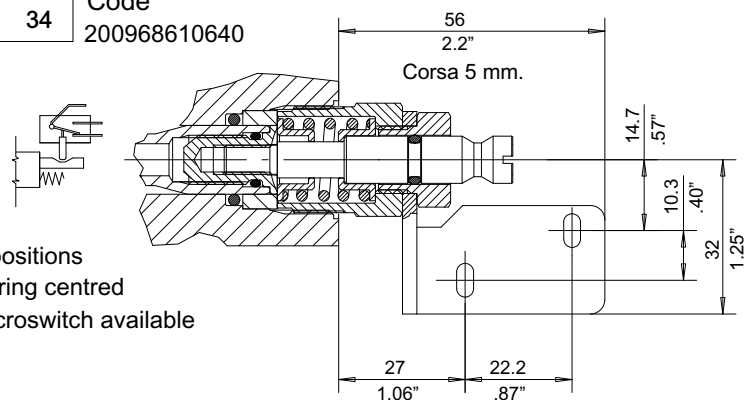

3 positions
Spring centred
Microswitch available

El. n.	Sectional valve body	Circuit	Posit.	Hand lever	Lever stick	Valves for sect. valve
9	1 H D 1 0 6 K N 2 2	A D C	0 1			

9.3.2 Hand lever

L100 Code
200907110200

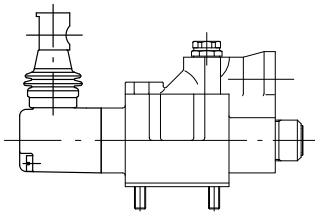

L129 Code
200907120050

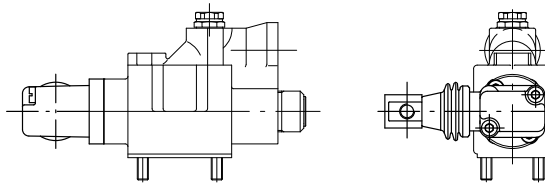

El. n.	Sectional valve body	Circuit	Posit.	Hand lever	Lever stick	Valves for sect. valve
9	1 H D 1 0 6 K N 2 2	A D C	0 1	L 1 0 0		

9.3.3 Lever stick

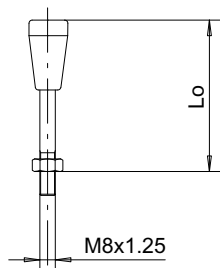

L ₀ Length	Type	Code
185 mm - 7.28 inches	AL001	200702210190
250 mm - 9.84 inches	AL002	200702210030
300 mm - 11.81 inches	AL003	200702210050
350 mm - 13.78 inches	AL004	200702210060

El. n.	Sectional valve body	Circuit	Posit.	Hand Lever	Lever stick	Valves for sect. valve
9	1 H D 1 0 6 K N 2 2	A D C	0 1	L 1 0 0	A L 0 0 1	

9.3.4 Preassembly code

Directional control valves
HD106-KN22-ADC-34-L100 Code: 200050619017

Mechanical piloted check valve
Code: 200987601770

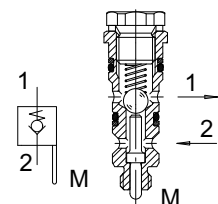

For further information and options, see directional controls valves catalogue chapter
HDM140
200 - P - 991214 - E - 13/03.13
UP100

10 Complete power packs

10.1 Typical application for Dock Leveller

Description

- For two single acting cylinders
- No solenoid require
- Automatic hydraulic sequence

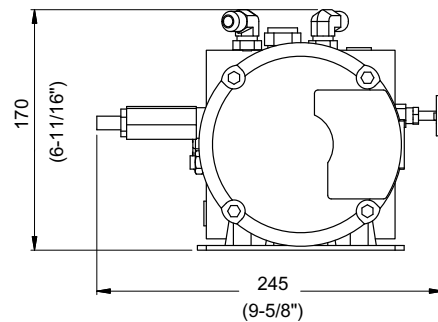
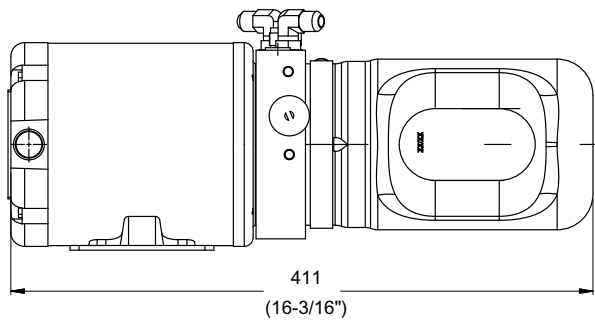
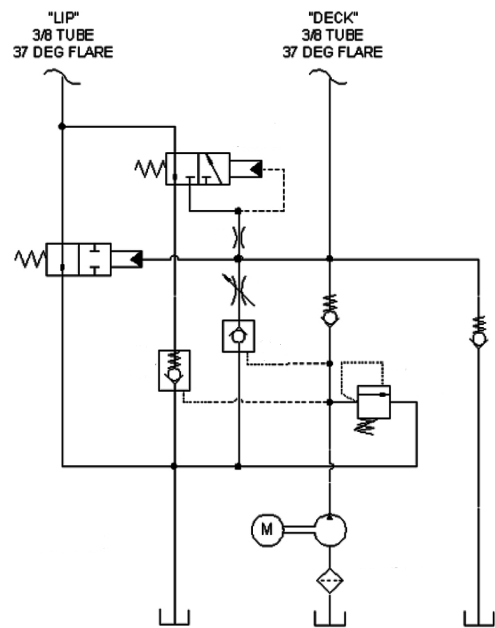
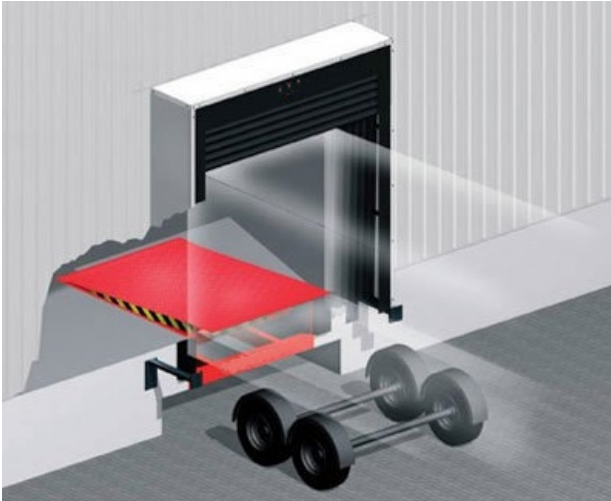

Consult Bucher Hydraulics for additional options and specifications

10.2 Typical application for Snow Plow

Description

- For one single acting and one double acting cylinder
- Compact solution

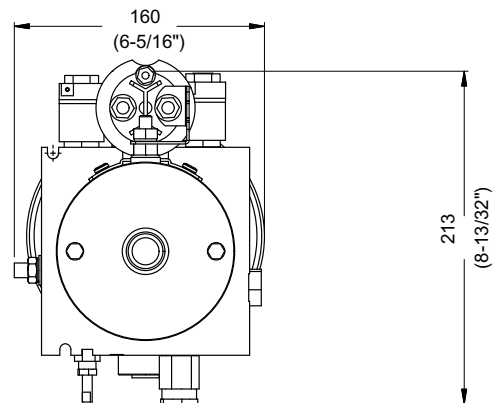
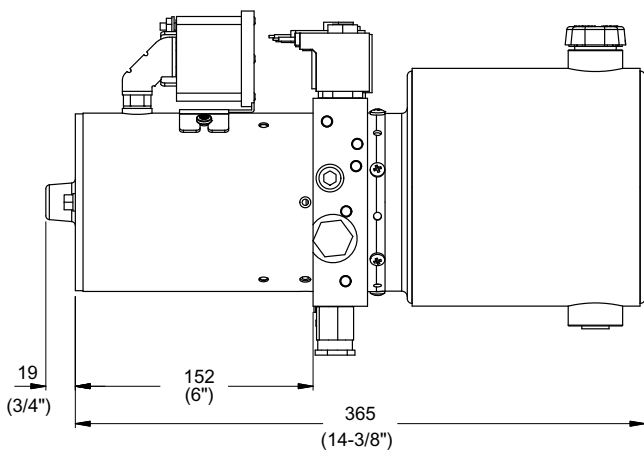
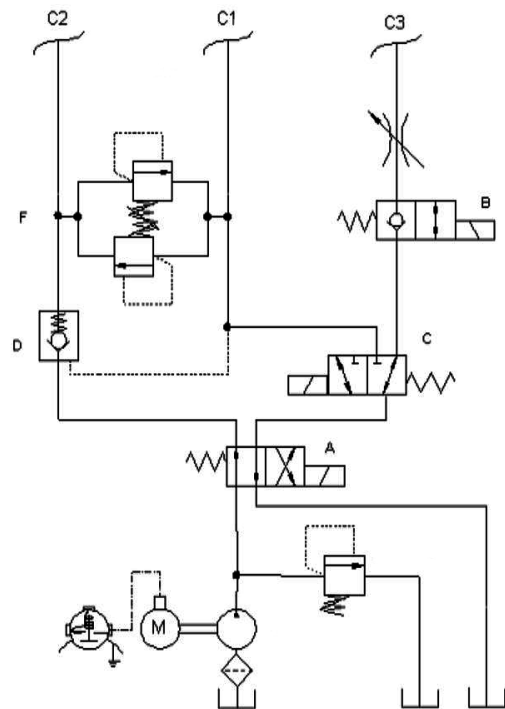

Consult Bucher Hydraulics for additional options and specifications

10.3 Typical application for Invalid Lift Equipment

Description

- Emergency hand pump
- Compact solution

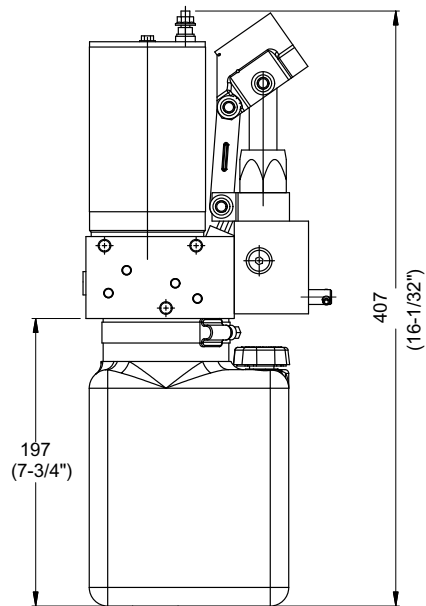
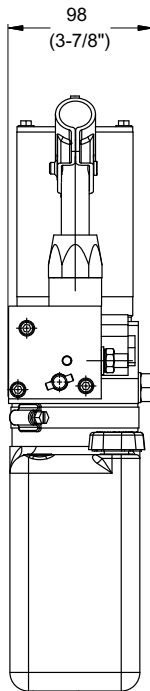
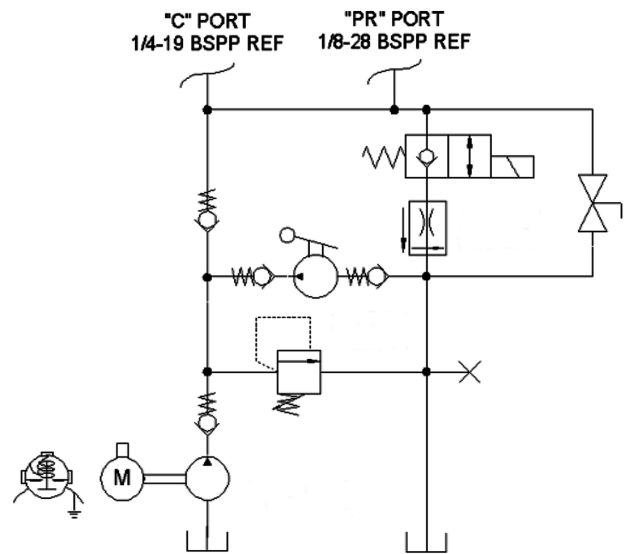

Consult Bucher Hydraulics for additional options and specifications

10.4 Typical application for Tailgate

Description

- For two single acting cylinders working independently

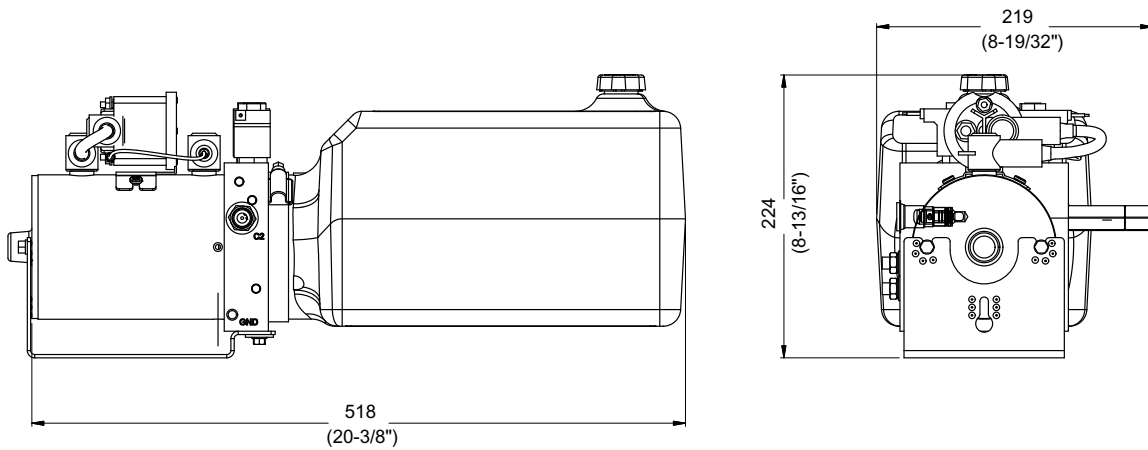
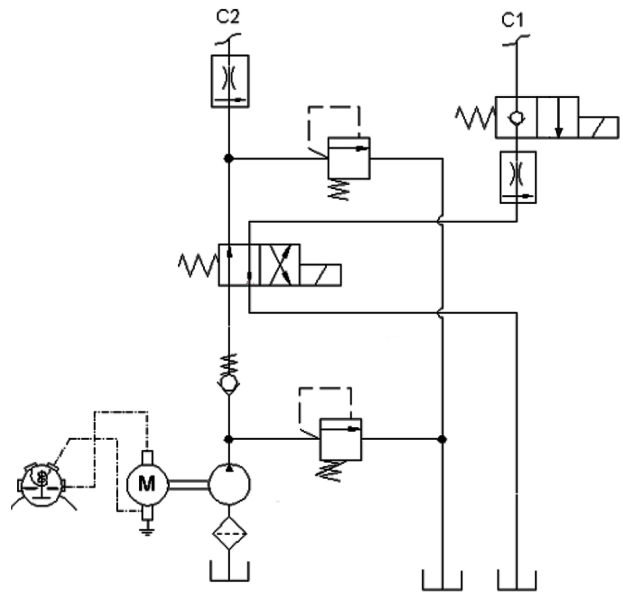

Consult Bucher Hydraulics for additional options and specifications

10.5 Typical application for Lift Table

Description

- For one single acting cylinder
- Automatic unloading valve
- Compact solution

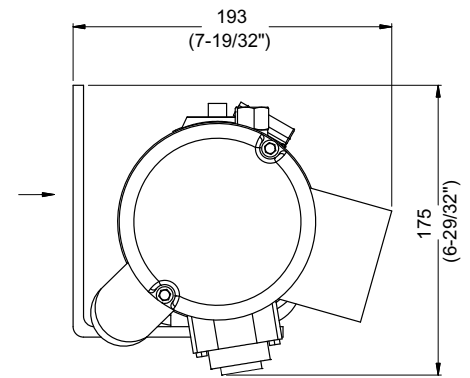
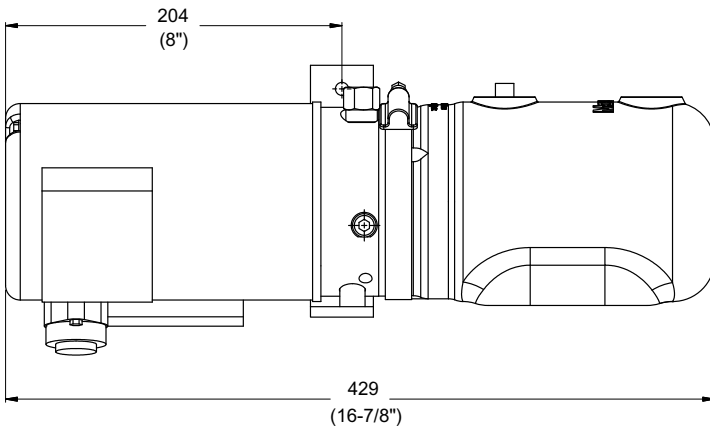
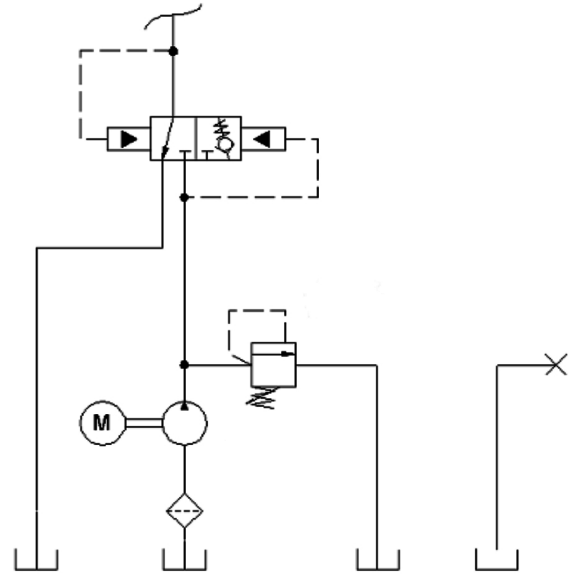

Consult Bucher Hydraulics for additional options and specifications

10.6 Modular system

Description

- Controls two double acting cylinders independently
- Double check valves for each cylinder

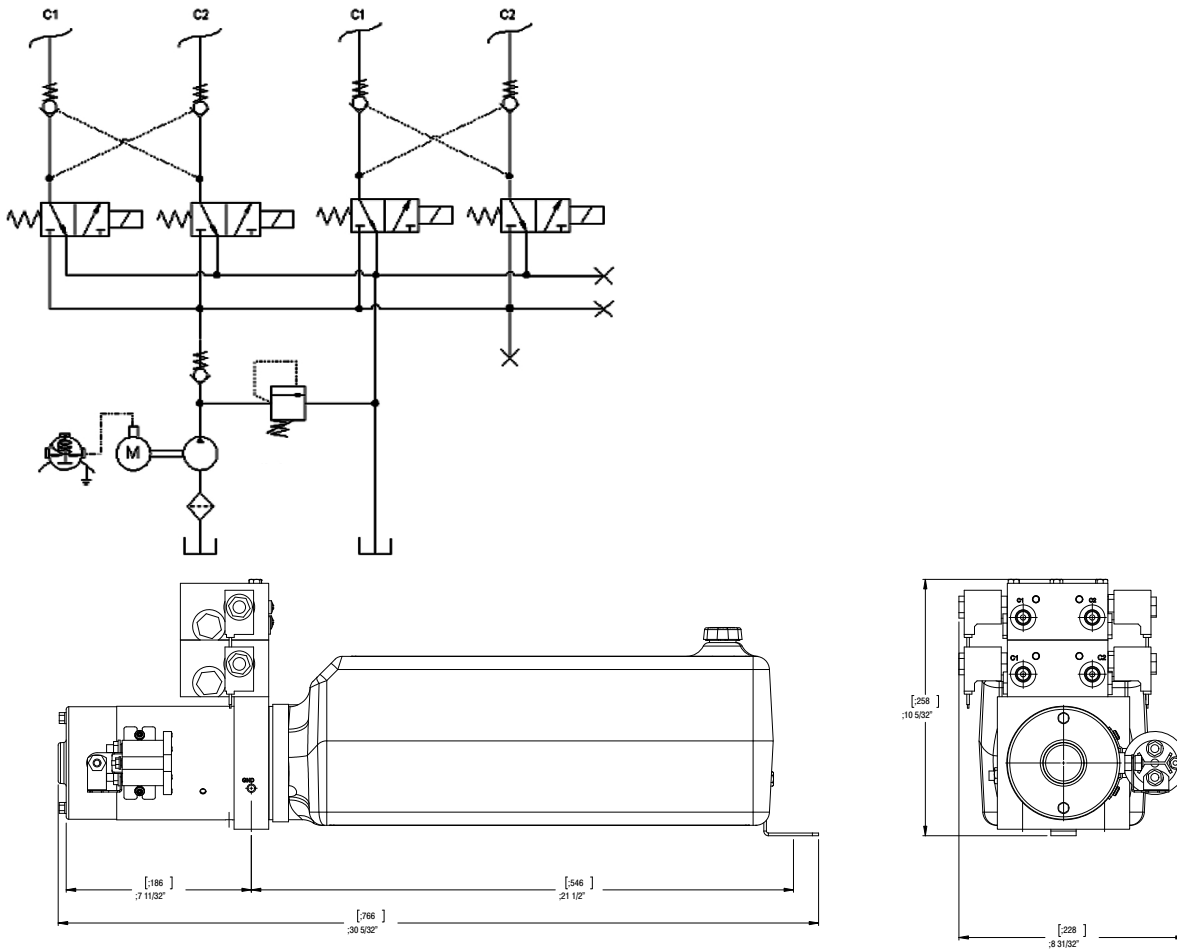

Consult Bucher Hydraulics for additional options and specifications

11 Components

11.1 Pressure gauge

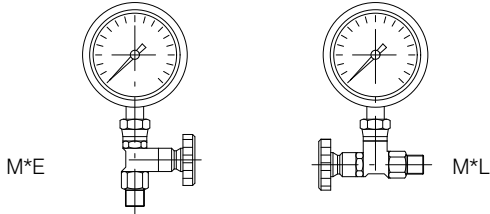

Pressure gauge M01 full scale 0-100 bar	200587322001
Pressure gauge M03 full scale 0-250 bar	200587322003
Cut out device type E	200534110001
Cut out device type L	200534110002
Pressure gauge M01 with cut out type E	200962000010*
Pressure gauge M03 with cut out type E	200962000030*
Pressure gauge M01 with cut out type L	200962000020*
Pressure gauge M03 with cut out type L	200962000040*

* The pressure gauge must be assembled, on housing and manifold, always together with cut out device

11.2 Steel plate bracket pressed for UP housing

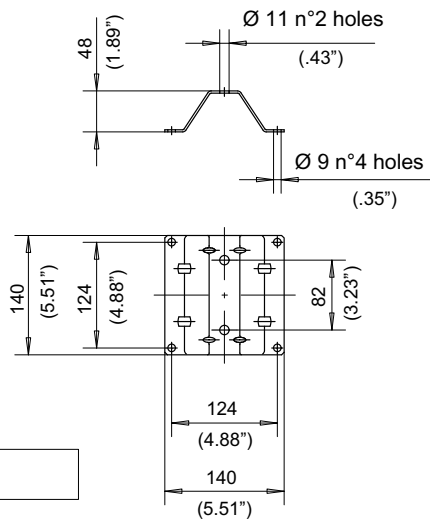

Code**
200777400120

** Supplied with screws and washers

11.3 Protective cover for D.C. motors

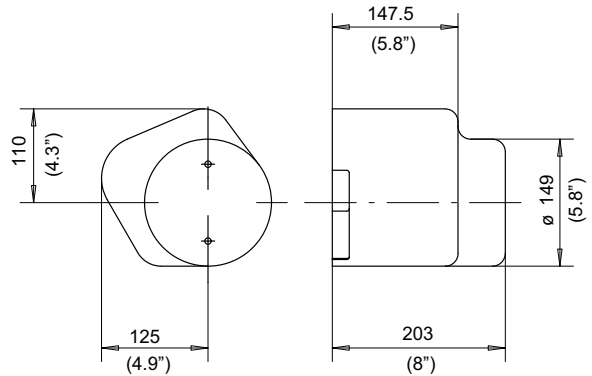

Code**
200968800090

Only for motors:
T82K, C134AK, C238AK

11.4 Microswitch

Code 200544124013

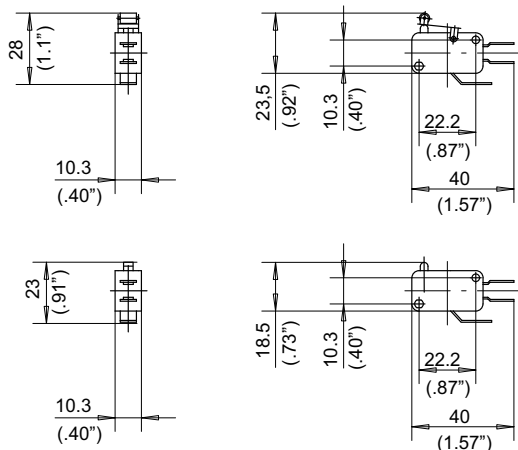

Code 200544124014

Code (micro only)	200544124013	200544124014
Complete code (micro+fixing kit)	200762500060	200762500050
Voltage	250 V.	
Index protection	IP00	
Nominal current	16 A.	
Max. current	20 A.	
Temperature range	-20/+125°C	
Max total stroke	2.6 mm.	
Working stroke	1.2 mm.	
Mechanical life	2x10 ⁷ cycles	
Suitable for	HD105-HD106	ZR817/**

11.5 Pressure switch

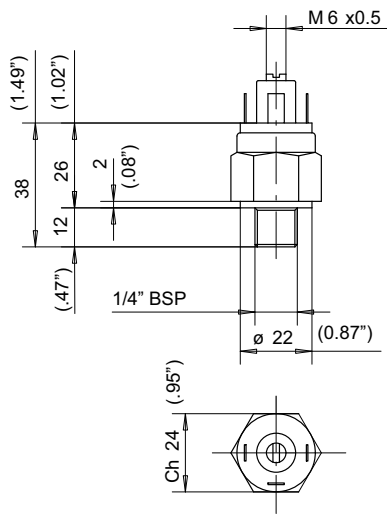

Setting hysteresis	+0/-0.5 bar
Max. voltage	220 V.
Working voltage	100 VA
Index protection	IP00
Resister current	0.5 A.
Inductive current	0.2 A
Temperature range	-5/+60°C
Max. number of cycles	200/min.
Insulation	1500 V.

Pressure range	Code	Versions
25- 50 bar	200544130009	normally closed
50 bar	200544130005	normally closed
60 bar	200544130020	normally closed
70-80 bar	200544130010	normally closed
80 bar	200544130011	normally closed
150-250 bar	200544130012	normally closed
20 bar	200544130014	normally open
60 bar	200544130021	normally open

12 Operation and maintenance

This chapter lists the main guidelines that should be followed to ensure smooth operation and long life service life of the power pack.

12.1 Oil

Use only a mineral based hydraulic oil responding to ISO/DIN 6743/4.

Other types of fluid can cause serious damage to the power pack and jeopardize its correct operation.

Recommended viscosity is between 20 and 120 mm²/s.

Contamination levels must be no higher than class 18/15 as prescribed by ISO 4406.

Check that the oil level is correct when filling the tank.

12.2 Starting

Connect the e. motor according to paragraph 5.2 and check that the direction of rotation is correct by supplying power for 1-2 seconds only.

For power packs which use pump series AP100 S409 and AP100 S509 the correct rotation is counterclockwise, viewed from the fan side.

Bleed the system of any air, then fill up the oil level in the tank after the initial period of operation.

For systems using solenoid valves with a.c. voltage, check before operating that is fitted the right type of electric connector.

12.3 Maintenance

Check the oil level in the tank on a regular basis.

Following the first few hours operation, inspect the return line filter to verify the rate of pollution, and generally check the level of contaminants in the oil.

Clean the tank inside periodically and replace the oil after every 600-800 hours operation.

In heavy duty conditions or hostile environments, inspections and oil changes should be carried out more often.

Likewise periodically, check the power connections to the electric motor, the solenoid valves and any other electrical accessories (e.g. microswitches, etc.).

In the event that the O-Rings of cartridge valves need to be renewed, use the replacement parts kit specified for each of the valves in the catalogue, positioning the seal and the backup ring as indicated.

Avoid makeshift arrangements using different seals.

12.4 Dealing with possible trouble

This is intended to assist those customers who choose to purchase single sub-assemblies separately and put together their own power packs. Listed below are some of the more commonplace problems that can occur if parts are not assembled correctly.

Trouble observed: Oil leaking from spigot on tank side	
Probable reasons:	Possible remedies:

O-Ring damaged

Inspect and replace O-Ring

Trouble observed: Motor turning but no pressure in circuit	
Probable reasons:	Possible remedies:

Hydraulic circuit wrongly assembled

Inspect position and type of plugs and valves fitted into the cavities

Solenoid valve normally open energized by not correct or lower tension

Check energizing with the correct nominal input voltage.

Solenoid valve normally closed but continuously energized.

Check electrical connections.

Electric motor rotates in wrong direction

Check and modify the electric connection

Pump bearings fitted incorrectly

Check and re-assembling correctly

Pressure relief valve set at not correct value

Check with a gauge and set to the correct pressure

The pump does not suck oil owing to low oil level in the tank

Check and fill the tank with correct oil level

The drive coupling between pump and e. motor is not correctly assembled

Check and assemble in the correct position

Trouble observed: Cylinder rod extends correctly, but fails to retract when unloading valve is opened	
Probable reasons:	Possible remedies:
Solenoid unloading valve not energized	Check electrical connections
Solenoid unloading valve not energized with nominal input voltage	Check power input and restore nominal voltage.
Solenoid valve has lower performances compared to the circuit requirements. consequently unable to handle flow/pressure.	Verify, and replace with a model giving higher performances.
The solenoid valve is blocked because of dirt in the system	Disassemble and clean
Valve solenoid damaged by overheating	Possible overvoltage. Check rated voltage of solenoid against input voltage. If system is using a.c., make certain the type of the connector is correct.

Trouble observed: Cylinder rod does not keep the position due to internal leakage	
Probable reasons:	Possible remedies:
Dirt in the system	Clean up components and restore system to a suitable level of cleanliness. Check that valve elements and seats are undamaged. Check piston seals for wear.

Trouble observed: Oil leaking on motor side	
Probable reasons:	Possible remedies:
Pump shaft seal damaged during assembling	Check seal, and replace if it is necessary

Trouble observed: High noise level	
Probable reasons:	Possible remedies:
Air in the system.	Bleed off any air by loosening a pressure line fitting
Possible damage to pump shaft oil seal damaged during assembly	Check seal, and replace if it is necessary
Drive coupling not fitted correctly	Inspect and assemble correctly
Coupling worn	Inspect and replace if necessary
Pump suction with air inside	Check the oil level in the tank and the connections between filter, suction pipe and pump

Trouble observed: High current consumption of the electric motor	
Probable reasons:	Possible remedies:
Motor incorrectly installed	Check correct mounting position if necessary
Low battery charge	Measure, and recharge if necessary
Pump O-Ring or backup ring not fitted correctly	Check, and if necessary replace O-Ring and backup ring.

Trouble observed: Electric motor continues to run even when switched off	
Probable reasons:	Possible remedies:
Wrong electrical connections	Check, and restore proper connections
Starting relay contacts are fuse together as a result of high current.	Disconnect power input immediately and verify condition of the contacts. Replace starter relay if necessary

13 Composition of hydraulic power pack ordering code

Assembled power pack example

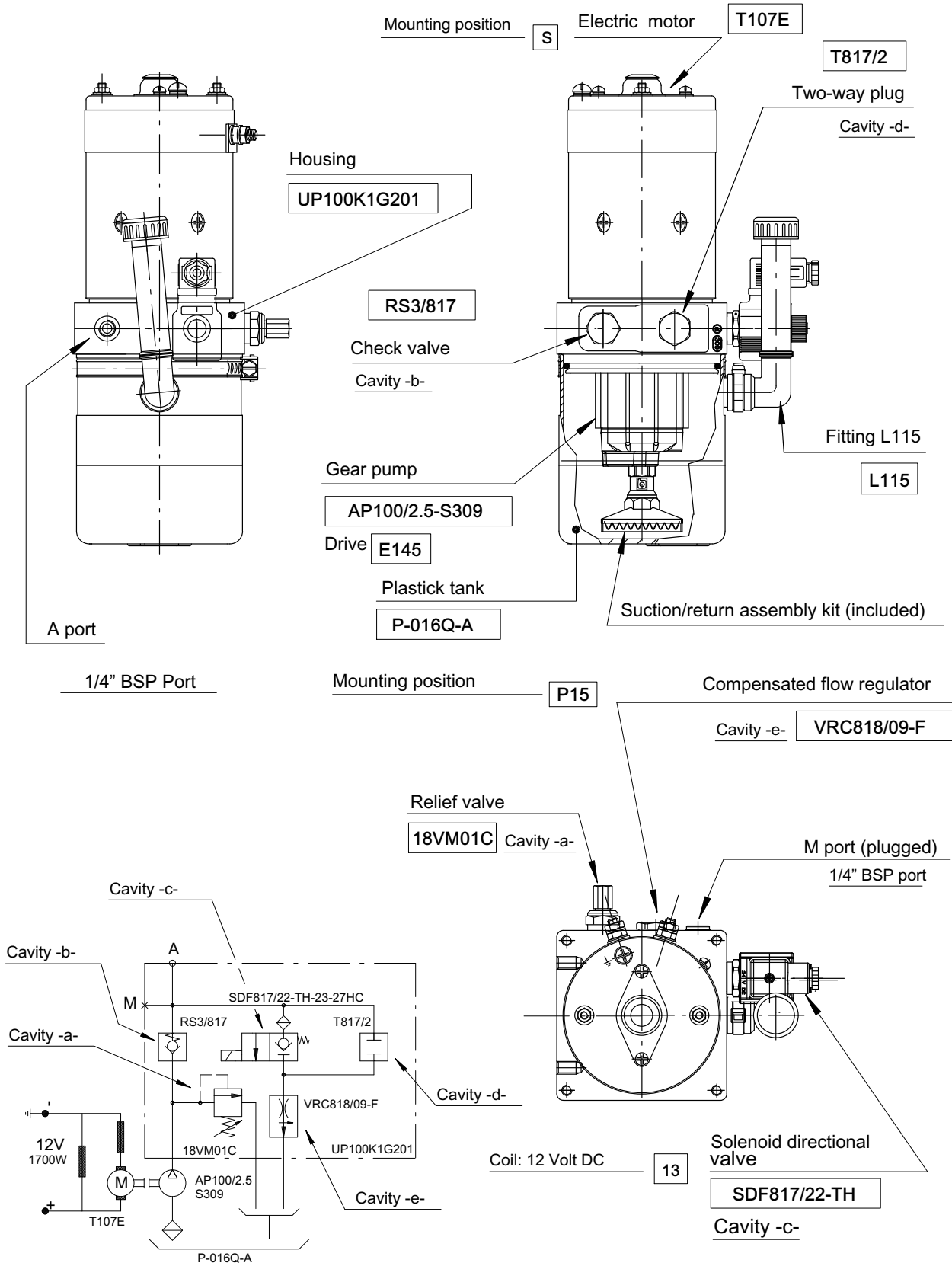

Example of hydraulic power pack ordering code

1	Type of housing	Vers.		
UP100/K1G201				
2	Pump	Hi-Lo Series		
AP100/2.5		S309		
3	Tank	Fitting	Pos.	
P-016Q-A	L115	P15		
4	Suction assembly kit	Tank fixing kit		
5	Electric motor	Pos.	Relay	Pos.
T107E	S			
6	Drive			
E145				

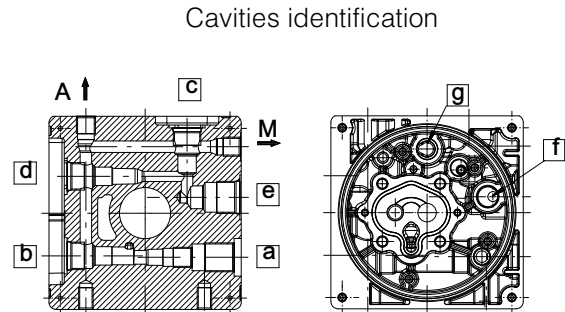

7	Cavity a	Cavity b	Cavity c	
	18VM01C	RS3/817	SDF817/22-TH	
	Cavity d	Cavity e	Cavity f	
	T817/2	VRC818/09-F		
	Cavity g	Hand lever	Stick lever	Volt
				13

Composition of product code

- UP100/K1G201 AP100/2.5S309
P-016Q-A L115 P15 T107E S E145
a) 18VM01C b) RS3/817
c) SDF817/22-TH-13-27HC
d) T817/2 e) VRC818/09-F

Product identification plate - Example

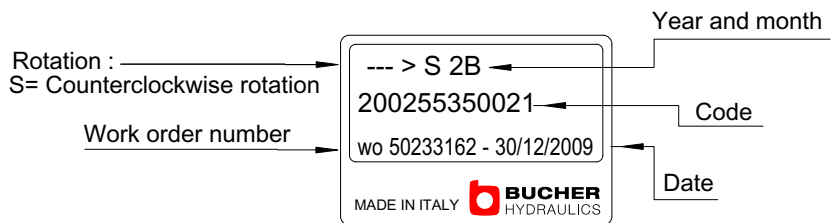

Manufacturing month	Manufacturing year							
	2010	2011	2012	2013	2014	2015	2016	2017
January	0A	1A	2A	3A	4A	5A	6A	7A
February	0B	1B	2B	3B	4B	5B	6B	7B
March	0C	1C	2C	3C	4C	5C	6C	7C
April	0D	1D	2D	3D	4D	5D	6D	7D
May	0E	1E	2E	3E	4E	5E	6E	7E
June	0F	1F	2F	3F	4F	5F	6F	7F
July	0G	1G	2G	3G	4G	5G	6G	7G
August	0H	1H	2H	3H	4H	5H	6H	7H
September	0I	1I	2I	3I	4I	5I	6I	7I
October	0J	1J	2J	3J	4J	5J	6J	7J
November	0K	1K	2K	3K	4K	5K	6K	7K
December	0L	1L	2L	3L	4L	5L	6L	7L

info.it@bucherhydraulics.com

www.bucherhydraulics.com

© 2012 by Bucher Hydraulics S.p.A., IT - 42124 Reggio Emilia.

All rights reserved.

Data is provided for the purpose of product description only, and must not be considered as warranted characteristics in the legal sense. The information does not relieve users from the duty of conducting their own evaluations and tests. Because the products are subject to continual improvement, we reserve the right to amend the product specifications contained in this catalogue.

Classification: 440.405.000