

## Safety for Hydraulics

Compac-type Proportional Valves  
Series CV

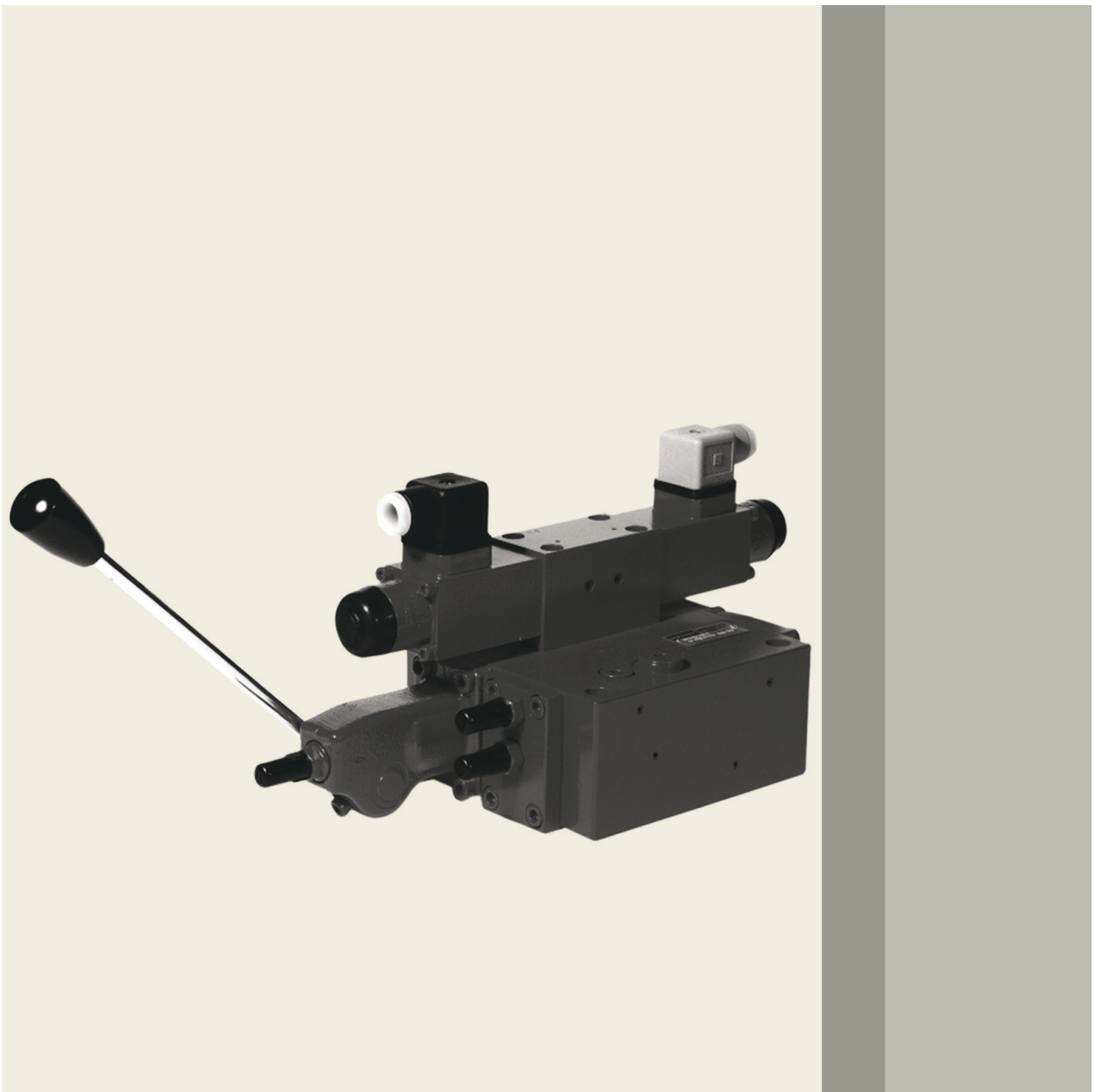

motion and progress

<b>Contents</b>		<b>Page</b>
<b>1</b>	<b>Functional description</b> .....	<b>3</b>
	1.1 The load check-back signal .....	4
	1.2 The flow characteristics .....	5
<b>2</b>	<b>Description of the valve types with example of circuit</b> .....	<b>6</b>
	2.1 Circuits with fixed displacement pump .....	6
	2.2 Circuits with adjustable control pump .....	8
<b>3</b>	<b>Actuating methods</b> .....	<b>10</b>
	3.1 Manual actuation .....	10
	3.2 Hydraulic actuation Y0 .....	10
	3.3 Electrical actuation E1/E2 / M2(M1), proportional .....	11
	3.4 Combined actuation .....	11
<b>4</b>	<b>Special functions/additional functions</b> .....	<b>12</b>
	4.1 Sandwich plate in the pilot circuit .....	12
	4.2 Actuator pressure protection separated on A and B sides .....	12
<b>5</b>	<b>Safety instructions</b> .....	<b>13</b>
<b>6</b>	<b>Assembly instructions</b> .....	<b>13</b>
	6.1 Views of a proportional valve .....	13
<b>7</b>	<b>Adjustment instructions</b> .....	<b>13</b>
<b>8</b>	<b>Sizes</b> .....	<b>14</b>
	8.1 General .....	14
	8.2 Actuating methods .....	15
	8.3 Type codes .....	18
	8.4 Position of the hand lever .....	20
	8.5 Spool symbols .....	20
<b>9</b>	<b>Dimensions</b> .....	<b>21</b>
	9.1 Valve types .....	21
	9.2 Valves with actuating methods H6 / H7 .....	22
	9.3 Valves with actuating methods S1, S2, S3, S4 .....	22
	9.4 Valves with actuating method Y0 .....	23
	9.5 Valves with actuating method E1/E2 / E7/E8 .....	24
	9.6 Valves with actuating method M2(M1) / M3(M4) .....	25
	9.7 Valves with actuating method M6(M5) / B6(B5) .....	26
	9.8 Valves with actuating method Y1/Y2 / Y7/Y8 .....	27
	9.9 Valves with actuating method B2(B1) / B3(B4) .....	28
	9.10 Valves with actuating method K1/K2 / K8(K5) .....	29
	9.11 Valves with actuating method K9(K6) / KO(K7) .....	30
	9.12 Valves with actuating method H0 .....	31
	9.13 Connection diagrams .....	32

# 1 Functional description

## CU / CD series

Bucher's Compac valves are plate-type valves. They control the volumetric flow to the actuator independent of the load. Compac means: all valves functions are integrated into one compact block. The valves comprise one pump connecting section and one proportional directional control valve section.

Using valve-internal load check-back signaling to the pressure compensator, the actuated directional control valve operates independent of the load and controls the flow to ports A and B proportional to the actuation signal. All the directional control valve sections can be actuated at the same time, e.g. when a number of CD Compac valves are being used (see section 2.2.2, p. 9\*).

A large number of valve variants allows optimum adaptation to the respective application. The actuating methods available - manual, hydraulic, electrical or any combination of these - and the variants with different pump connecting sections (with 2- or 3-way pressure compensator or pressure relief valve) open up a wide range of applications.

Hydraulic and electrical actuation can be performed by means of remote-control units and electronic amplifier cards that are perfectly adapted to the proportional valves. Thanks to their plate-type design, these valves can be used with other Compac valves, screw-type cartridges or other plate-type valves in an innumerable number of combinations. We are, of course, only able to illustrate a small number of typical circuits in this catalog. Please don't hesitate to contact us. Tell us about your particular application. We can suggest a functional and inexpensive solution to your problem. The block structures required for assembling the Compac valves can naturally also be ordered from us.



**\* Remark:** Simultaneous, load-independent operation of several actuators enables us to offer a series of sandwich-type valves (see brochure 301-P-9050022). Each valve section in the sandwich-type valves is equipped with its own pressure compensator.

## 1.1 The load check-back signal

The load check-back signal is sent from the directional control valve section being actuated to the pump connecting section in the same way for all types of valve. In the diagram below, the main control spool of proportional directional control valve 2 is in its neutral position while main control spool 1 is actuated and consequently connects pump port P to actuating port A and actuating port B to tank port T. Immediately before metering edges P/A and B/T are opened, port A is connected to the spring cavity of the pressure compensator via load signaling channels in the spools and housing. Valves with several control spools are equipped with check valves in the load signaling channels. The load pressure signal can be tapped at port XL (in the area of the pump connecting section). In the neutral position of all proportio-

nal directional control valves, the load signaling channels are separated from the actuators. The pressure compensator is then depressurized by means of the DUE2 relief jets. Valves of type CU integrate not only directional-control-valve and 3-way-flow-control functions but also the functions of a primary pressure relief valve (only when the directional control valve is open) and bypass valve (when the directional control valve is closed). This valve is therefore particularly suitable for use with a fixed displacement pump. Valves of type CD enable not only directional-control-valve and 2-way-flow-control functions but also the pressure reduction function (only when the directional control valve is open and when the preset pressure setting is exceeded).

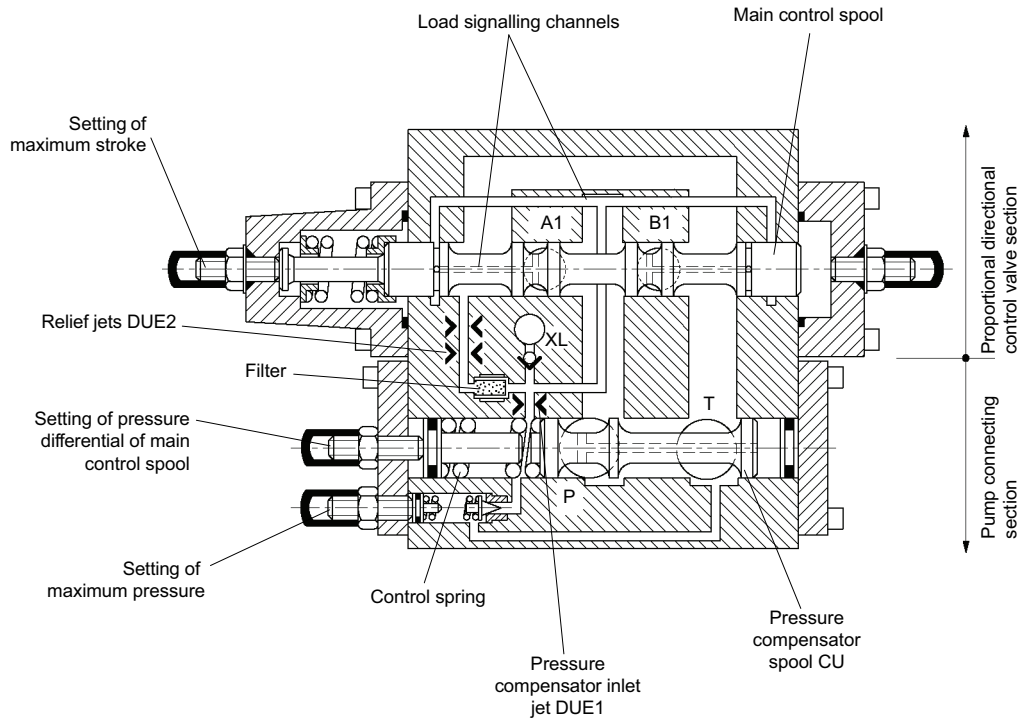

## 1.2 The flow characteristics

The directional control valves can be equipped with spools with different flow paths (see section 8.5, p. 20, Spool symbols). The control cross-sections between the pump ports and actuator ports can be adapted individually for the respective application (see fig. 1.2.2). This makes it possible to operate asymmetrical actuators, such as differential cylinders, at the same maximum speed in both directions of

travel making full use of the stroke of the spool. When the directional control valves are in their neutral position, the 3-way pressure compensator adopts the circulation position from P to T. The circulation pressure differential that arises is approx. 2 to 8 bar higher than the directional-control-valve pressure differential.

### 1.2.1 Flow characteristics with maximum displacement of main control spool

Q [%]	NG12 Q [l/min]	NG18 Q [l/min]	NG25 Q [l/min]
100	100	200	450

### 1.2.2 Pressure drop at the main spool metering edges as a function of the valve flow rate, see also section 1.2.1

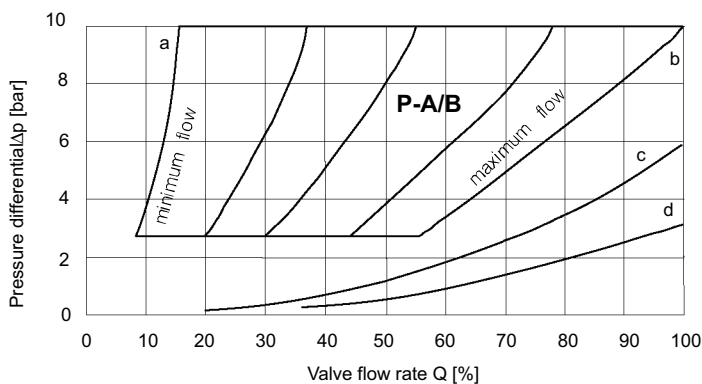

The chart shows the limits of application. The volumetric flow rates quoted are guidelines. They depend on a great number of parameters and must be determined on a case by case basis

Legend	a	Connection P-A/B with minimum cross-section	c	Connection A/B-T (spool model A) Connection A-T (spool model D, F, L) Connection B-T (spool model B, G, K)
	b	Connection P-A/B with maximum cross-section	d	Connection A/B-T (spool model C) Connection A-T (spool model B) Connection B-T (spool model D)

## 2 Description of the valve types with example of circuit

### 2.1 Circuits with fixed displacement pump

#### 2.1.1 Valve type CU: pump connecting section with 3-way pressure compensator

##### Circuit valve function

When the proportional directional control valve is in its neutral position, the load check-back signal from the two actuator ports A and B to the pressure compensator is interrupted. The combination of jets located in the load signaling channel lowers the pressure in the spring cavity to the pressure level in the tank. The delivery rate generated by the pump is fed back to tank port T via the pressure compensator with a slight pressure difference.

##### 3-way flow control function

If the main control spool is displaced beyond the area of overlap, the load check-back signal is sent to the spring cavity of the pressure compensator. Due to the combined action with the pressure compensator, a constant pressure difference that is independent of the load pressure arises at the infinitely variable restrictor areas of the main control spool. In this way, a load-independent actuator flow arises, that is dependent only on the position of the control spool. The excess pump delivery rate returns to the tank.

##### Pressure relief valve function

If the pressure in the actuated actuator port rises above the value specified by the maximum pressure protection device due to the load, the maximum pressure valve opens and the pressure compensator spool assumes the function of the main stage of a pressure relief valve.

### Example of a circuit with valve type CU

Preferred application with fixed displacement pump for load-independent control of the volumetric flow.

In addition, the pump connecting section takes care of maximum pressure protection of the entire system and serves as a recirculation valve with non-actuated actuators.

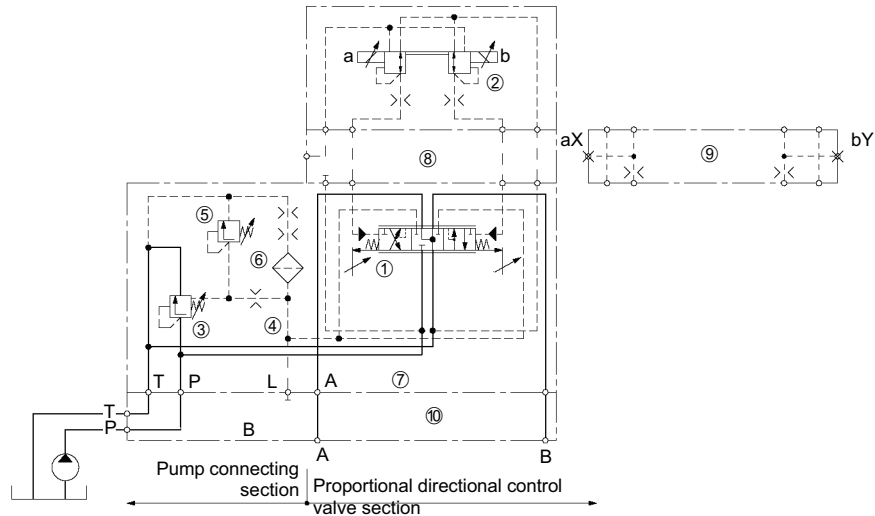

### Example with electrical actuation

In the valve variant illustrated above, a pressure regulator is used as a pilot stage for actuating the main control spool. For a functional description and characteristics, see section 3.3, page 11.

Legend	<b>1</b>	Proportional directional control valve	<b>6</b>	Relief jets for the load check-back signal system
	<b>2</b>	Pressure control valve (pilot valve)	<b>7</b>	Actuator connections
	<b>3</b>	3-way pressure compensator	<b>8</b>	Sandwich plate in the pilot circuit, external control oil supply, see section 4.1, page 12
	<b>4</b>	Load check-back signal	<b>9</b>	Sandwich plate in the pilot circuit, tapping of the pilot pressure signal, see section 4.1, page 12
	<b>5</b>	Pressure relief valve (pilot stage)	<b>10</b>	Assembly plate (example)

## 2.2 Circuits with adjustable control pump

### 2.2.1 Valve type CL: pump connecting section with pressure relief valve

The pump connecting section comprises a pilot-controlled pressure relief valve with pilot stage V and main stage H. The valve does not have recirculation-valve and flow-control functions. If pressure-regulated (a) or pressure- and delivery-rate-regulated (load-sensing principle) (b) variable displacement pumps also have to be protected, a valve of type CL with primary pressure protection must be fitted.

When pressure-regulated pumps are being used, relief jet E1 can be replaced by a plug (must be specified in order). For pumps with load-sensing control, the load signal can be tapped at port XL. The load at the pump control valve when the main spool is in neutral position can be relieved at the pump end (E2) or the valve end (E1) (must be specified in order).

 **Remark:** To enable us to set up the valve, we require  $\Delta p$  of the pump regulator.

#### Example of circuit with valve type CL

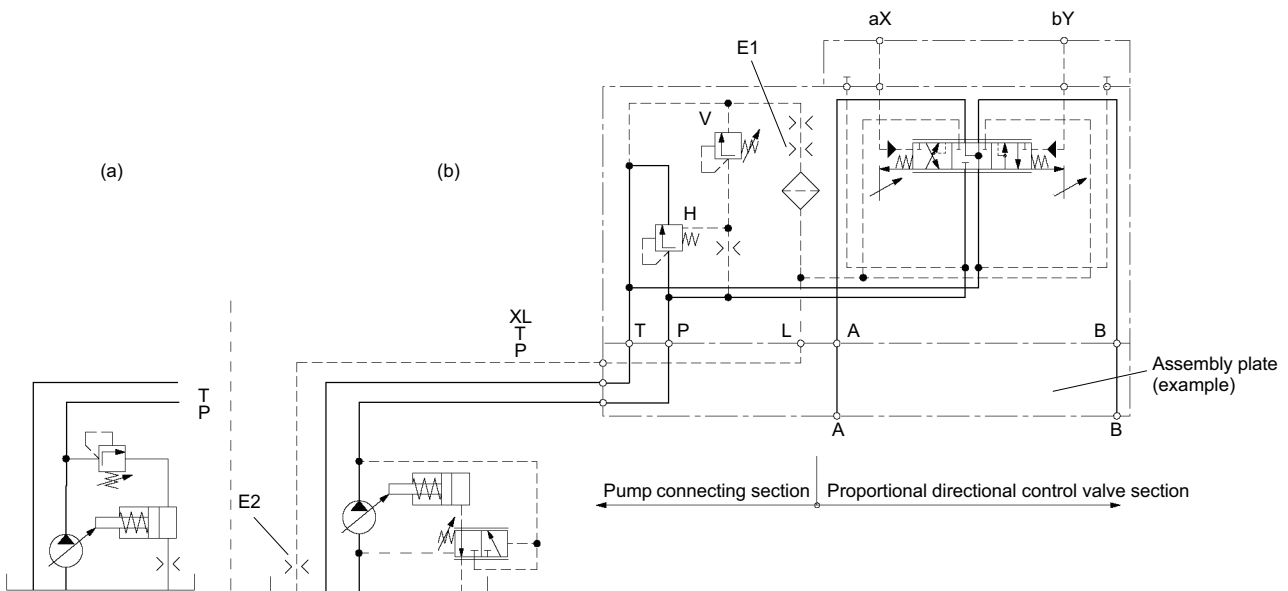

#### Example with hydraulic actuation (e.g. via control pressure sensor)

The control pressure differential required for adjusting the main control spool is generated by an external hydraulic control unit and fed via ports aX and bY to the directional control valve.

For a functional description and characteristics, see section 3.2, p. 10.



## 2.2.2 Valve type CD: pump connecting section with 2-way pressure compensator

Seen in the direction of flow, from P to A or B, located upstream of the main control spool is a 2-way pressure compensator which, together with the metering orifice formed by the control spool, effects the load-independent flow control function.

When the pressure in the actuated actuating port A or B rises due to loading above the value specified by the maxi-

mum pressure protection device, the pilot pressure relief valve (V) opens. As a result, the pressure compensator closes the metering edge between the high-pressure (HD) and low-pressure (ND) channels.

The volumetric flow from the pump to the actuator is reduced until it is completely interrupted; the pressure reduction function comes into effect.

### Example of circuit with valve type CD

The figure illustrates electrical actuation. For a functional description and characteristics, see section 3.3, p. 11.

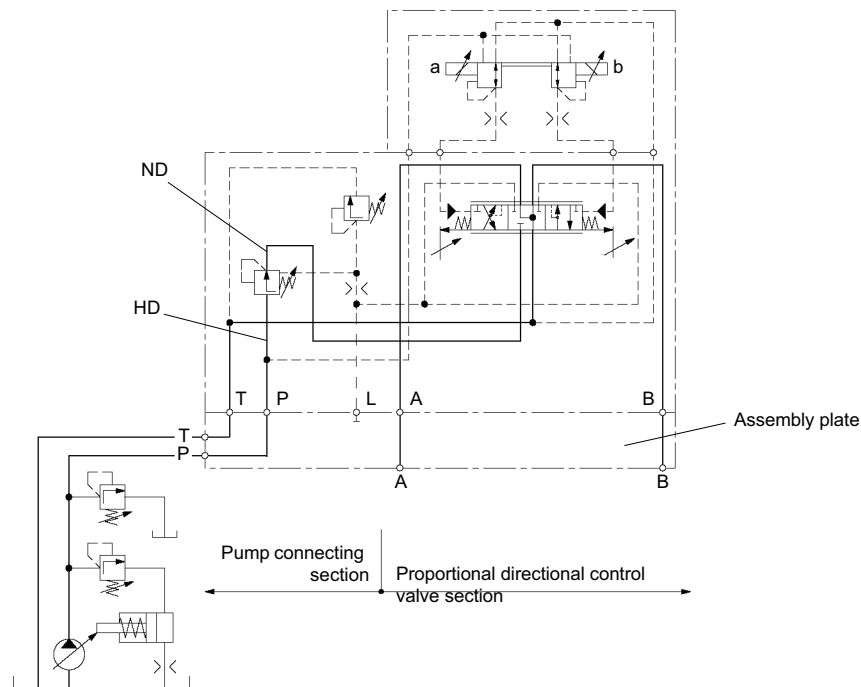

### Pressure-regulated pump

With a pressure-regulated pump and 2-way flow control, this is a system which enables for a single actuator load-independent flow control at a constant supply pressure and a delivery rate adapted to the particular requirements.

This type of circuit is disadvantageous from the point of view of energy when there is a great difference between the system and actuator pressures.

### 3 Actuating methods

All common methods of actuation can be used with our compact valves - manual, hydraulic, electrical and combinations of these.

The designations H6, H7, S1 ... S4 etc. refer to the type code (see section 8.3, p. 18).

#### 3.1 Manual actuation

##### 3.1.1 Actuation H6

The manual actuation unit acts directly on the main spool. The housing of the manual actuation unit is pressure-tight up to 50 bar. The lever length required when the valve spool is in the neutral position must be specified when ordering (see section 8.4, p. 20).

The main control spool and the actuating element are held in the neutral position by a spring-loaded centering mechanism. The actuating force increases as the displacement increases. For technical data, see section 8.2.1, page 15.

##### 3.1.2 Manual actuation with switching contact S1...S4

This actuating method is similar to H6 actuation, but is equipped with electrical switching contacts that serve to activate and deactivate additional and auxiliary functions (valves, drives, relays etc.). Normally closed, normally open and changeover contacts can be implemented. See diagram in section 9.3, p. 22.

##### 3.1.3 Manual actuation with positional locking and friction H7

With this actuating method, the main control spool is not spring-centered; once the displacement has been set, it is maintained through self-locking.

#### 3.2 Hydraulic actuation Y0

In unactuated state, the main control spool is held in neutral position by a centering spring. When pressure is applied to control channels aX / bY, the main control spool is displaced proportional to the control pressure differential applied. For technical data, see section 8.2.2, p. 15.

Manually actuated, hydraulic pilot devices are used to generate the control pressure differential.

Technical information on request.

### 3.3 Electrical actuation E1/E2 / M2(M1), proportional

An electrically and proportionally actuated pressure regulator serves as a pilot valve, the pressure as standard being supplied to it internally from the pump channel. The return line is connected internally to the tank channel.

The main control spool is spring-centered and is displaced proportional to the electrical control current by the control pressure differential regulated by the pilot valve (see control characteristics, figure 3.3.1). The supply and return of control oil requires the following minimum pressure differentials

between the pump and tank ports or between the external ports: 8 bar for opening and 20 bar for full displacement of the main control spool.

The electrical control current is converted to a control pressure differential by proportional solenoids that continue displacing the pilot spool until an equilibrium of forces is achieved at the pilot spool between the magnetic force and the control pressure differential.

For technical data, see section 8.2.3, p. 16.

#### 3.3.1 Transient function

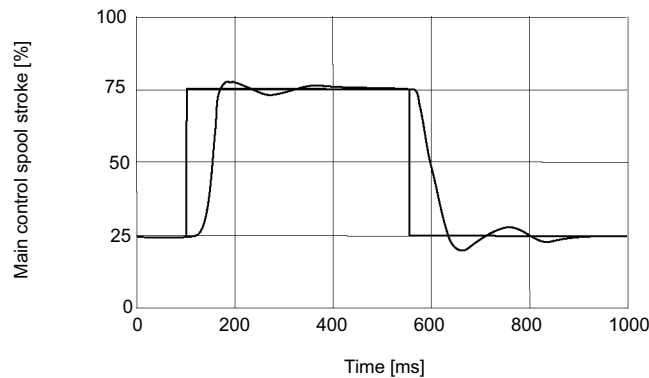

Transient function with step-shaped electrical input signal 50 % ± 25 %.

### 3.4 Combined actuation

#### 3.4.1 Hydraulic/manual H0

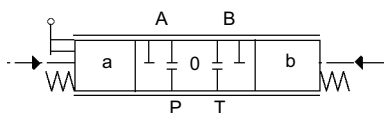

Priority is given to manual actuation when the actuating forces require this.

#### 3.4.2 Electrohydraulic/manual K...

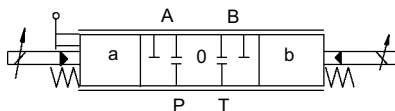

Priority is given to manual actuation when the actuating forces require this.

#### 3.4.3 Electrohydraulic/hydraulic Y../B..

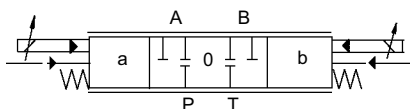

With this combination, the actuating method that is active is always that with the greatest control pressure differential.

## 4 Special functions/additional functions

In addition to the standard valve versions described in sections 1 to 3, there are numerous additional functions available for customizing systems to the particular requirements for the control tasks to be solved. Section 4 provides an overview of the most important of these additional functions.

More detailed information is available on request.

### 4.1 Sandwich plate in the pilot circuit

Sandwich plates in the pilot circuit (assembly beneath the pilot valve), e.g. for external control oil supply (see figure in section 2.1.1) or for tapping the pilot pressure signal (see figure in section 2.1.1).

Special options possible on request.

### 4.2 Actuator pressure protection separated on A and B sides

A further option is that of different pressure protection for the actuator ports A and B. It must be noted that the pressure at port B can only be set to a value lower than that at port A (see figure 4.2.1).

ceeds the values set at the pilot valves and the main control spool is open, the pressure compensator spool acts as a pressure relief valve in CU and CL valves and as a pressure reducing valve in CD valves.

With this additional function, separate pilot pressure relief valves are fitted for ports A and B. If the load pressure ex-

#### 4.2.1 Example of circuit for separate actuator pressure protection in a CD valve

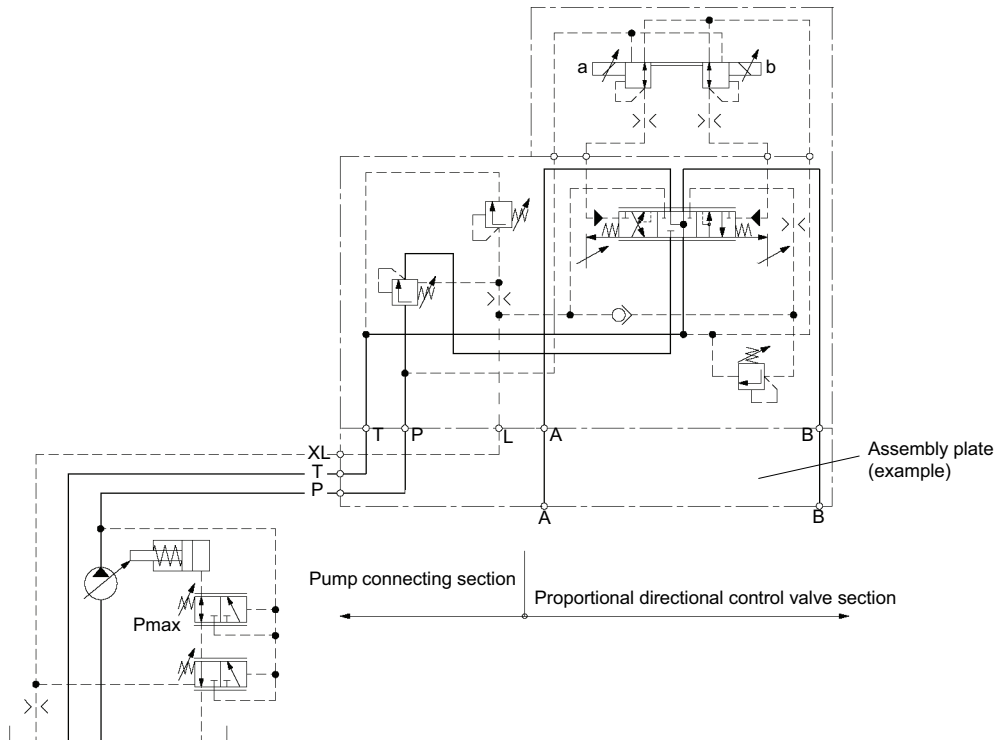

## 5 Safety instructions

Look for this User's Information about Proportional Valves in Monoblock and Compac type with the reference number 301-P-9050027.

## 6 Assembly instructions

### 6.1 Views of a proportional valve

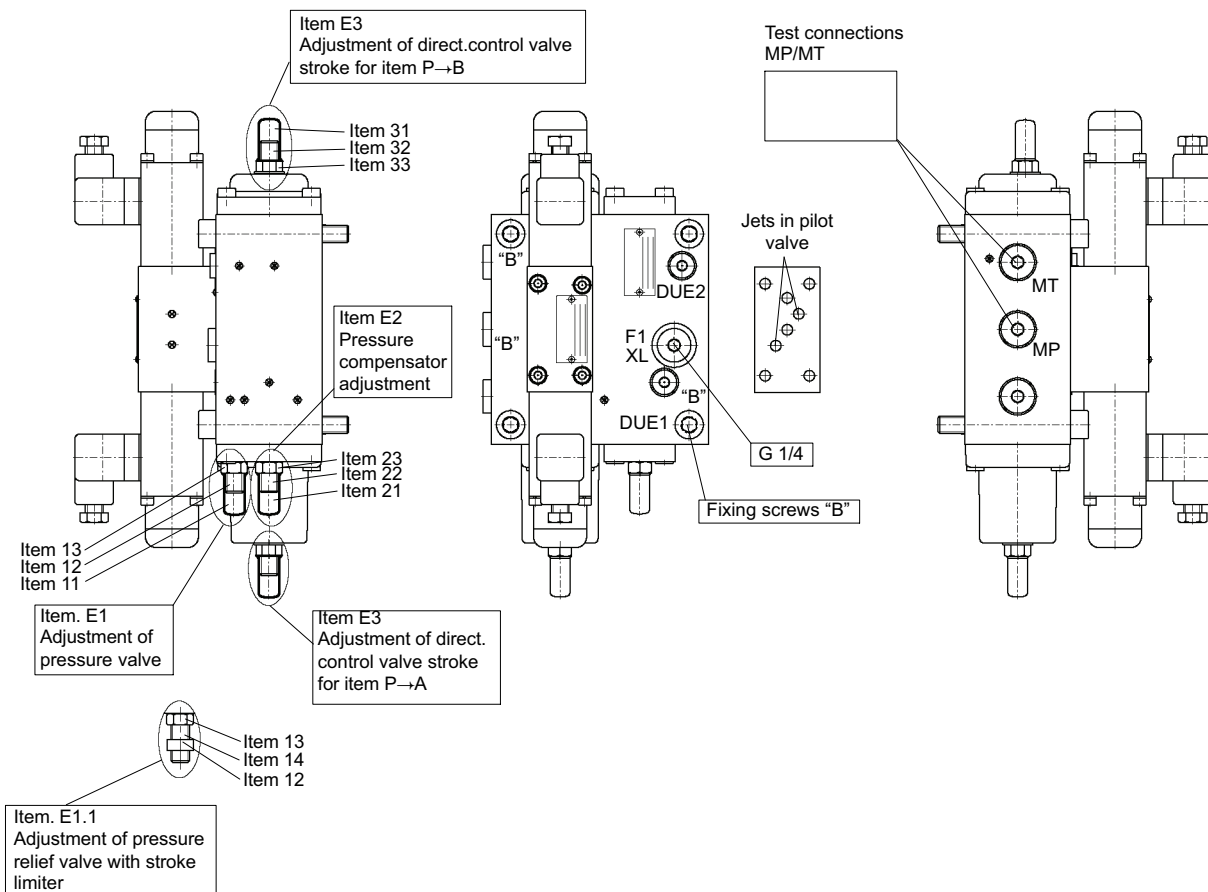

#### IMPORTANT!:

- Never lift up the valve by its solenoids, displacement sensors or other similarly sensitive components.
- Required surfaces quality of the mating component:

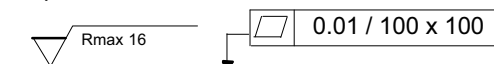

- Make sure that the mounting surface is clean.
- Tighten the valve fixing screws ("B", see fig. 6.1) the specified tightening torque (see section 7).

## 7 Adjustment instructions

Look for this User's Information about Proportional Valves in Monoblock and Compac type with the reference number 301-P-9050027.

## 8 Sizes

### 8.1 General

General characteristics	Description, value, unit
<b>Design</b>	all functions: spool valve pilot relief valve: seat valve
<b>Actuation</b>	electrically actuated proportional, hydraulic, manual
<b>Type of connection</b>	Company standard: see section 9, p. 21 for connecting thread
<b>Installation position</b>	any (look for a good ventilation)
<b>Weight</b>	see table 8.1.1, p. 15
<b>Ambient temperature range</b>	-30 ... 60°C
<b>Hydraulic medium</b>	mineral oil per DIN 51524 and DIN 51525 (HL/HLP)
<b>Recommended pressure fluid temperature</b>	20 ... 60°C
<b>min. temperature</b>	-20°C
<b>max. temperature</b>	80°C, other temperature on request
<b>Recommended viscosity range</b>	15 ... 100 mm <sup>2</sup> /s
<b>min. viscosity</b>	10 mm <sup>2</sup> /s
<b>max. viscosity</b>	380 mm <sup>2</sup> /s
<b>Filtering/purity class</b>	see table 8.1.2, p. 15
<b>Max. working pressure</b>	
<b>Port P/A/B</b>	... 350 bar
<b>Port T</b>	... 50 bar
<b>Max. pump delivery rate</b>	NG 12: 200l/min. NG 18: 400l/min. NG 25: 900l/min.
<b>Nominal flow</b>	NG 12: 100l/min. NG 18: 200l/min. NG 25: 450l/min.
<b>Flow characteristics</b>	see figure 1.2.2, p.5

### 8.1.1 Weight of valves CU, CD and CL in kg

Actuation	NG 12	NG 18	NG 25
H6	4.0	7.3	-
H7	4.1	7.5	-
Y0	4.3	7.6	31.7
E1, E2, M2(M1), M3(M4)	5.8	9.1	34.0
K0 ... K9	6.4	9.9	-
H0	4.3	7.6	-
Y1, Y2, B2(B1), B3(B4)	7.8	11.1	36.0

### 8.1.2 Functional safety and service life requirements

ISO 4406	class 18/15
NAS 1638	class 9

## 8.2 Actuating methods

### 8.2.1 Manual

<b>Max. actuating angle</b>	approx. 20 degrees		
<b>Actuating force</b>	<b>neutral pos.</b>	NG 12:	1.4 daN
		NG 18:	2.2 daN
	<b>max. control</b>	NG 12:	4.2 daN
		NG 18:	6.6 daN

### 8.2.2 Hydraulic

<b>Control pressure range</b>	6...18 bar
-------------------------------	------------

### 8.2.3 Electrohydraulic

Proportional with 12 V and 24VDC standard solenoids		
Hysteresis of end value	≤6 % of rated current (control with 70 -100 Hz PWM signal)	
Recovery time for control spool stroke 25 %-75 %	Control characteristics (Figure 3.3.1, p. 11)	
Recommended dither freq.	70...100 Hz	
Supply pressure (internal and external) for the pilot valve	20...350 bar (during the internal supply the circuit pressure has to be at least 8 bar in the resting position of the main spool valve)	
Type of protection per DIN 40050	IP65	
Cyclic duration factor	100 %	
Insulation class	F	
Max. ambient temperature	45°C	
Voltage type	DC voltage	
Rated voltage	12 V	24 V
Coil resistance 5 % at 20°C	4.9 Ω	19.6 Ω
Coil resistance 5 % at 60°C	5.67 Ω	22.7 Ω
Control current range for Q = 0...100 %	480 ... 1200 mA	260 ... 650 mA
Power input at max. valve displacement (coil resistance at 60°C)	8.2 W	9.6 W
Max. perm. current	1.9 A	0.95 A
Inductance (start of stroke...end of stroke)	0.07...0.13 H	0.29...0.55 H
Electrical connection	Power socket per DIN EN 175301-803 (DIN 43650)	

Switching (ON/OFF) in explosion-proof version (intrinsicallysafe)		
Type of protection per EG RL 94/9	 I M2 EEx ia I	
Rated voltage	12 V	
Making current	260 mA	
Holding current	130 mA	
Power input	Switch-on Holding	3.2 W 1.6 W
Solenoid certification	DMT 99 ATEX E 102	



Proportional as explosion-proof version (intrinsically safe)	
Type of protection per EG RL 94/4	 I M2 EEx ia I
Rated voltage	12 V
Control current range for Q = 0...100 %	90...270 mA
Power input at max. valve displacement	< 2 W
Solenoid certification	DMT 99 ATEX E 102

## 8.3 Type codes

### 8.3.1 Type codes with example for ordering

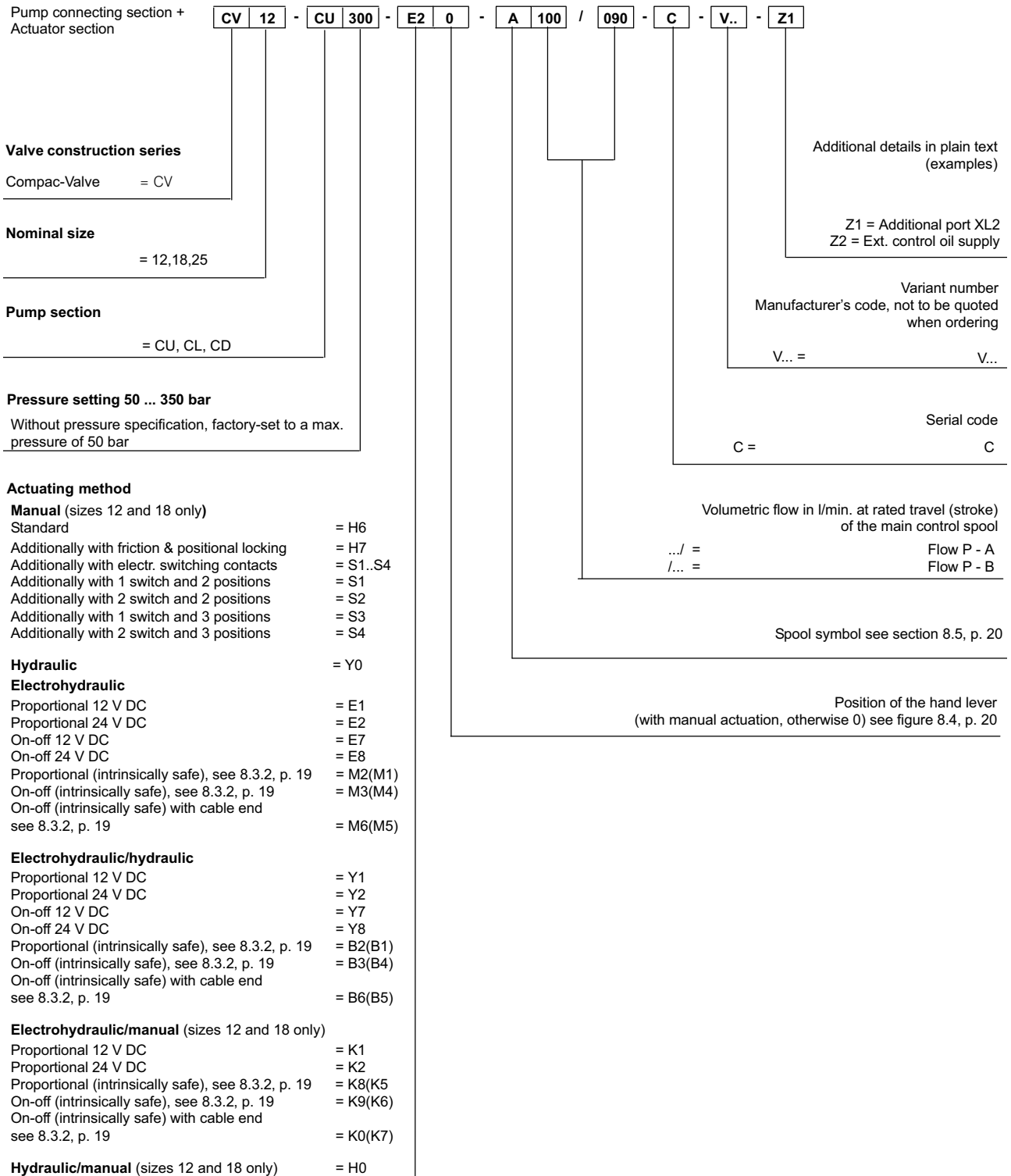

### 8.3.2 Type code table

	Old unit 30.06.03	New from 01.07.03
<b>Designation</b>	EE ia I	 I M2 EEx ia I
<b>Approval No.</b>	BVS Nr. 85.1035	DMT 99 ATEX E 102
<b>Electric proportional ON/OFF</b>	M1	M2
	M4	M3
	M5*	M6*
<b>Electro-hydraulic prop. ON/OFF</b>	B1	B2
	B4	B3
	B5*	B6*
<b>Electro-mech. prop. ON/OFF</b>	K5	K8
	K6	K9
	K7*	K0*

\* on request only

## 8.4 Position of the hand lever

Manual actuating methods H0/H6/H7/K/S  
Possible lever positions

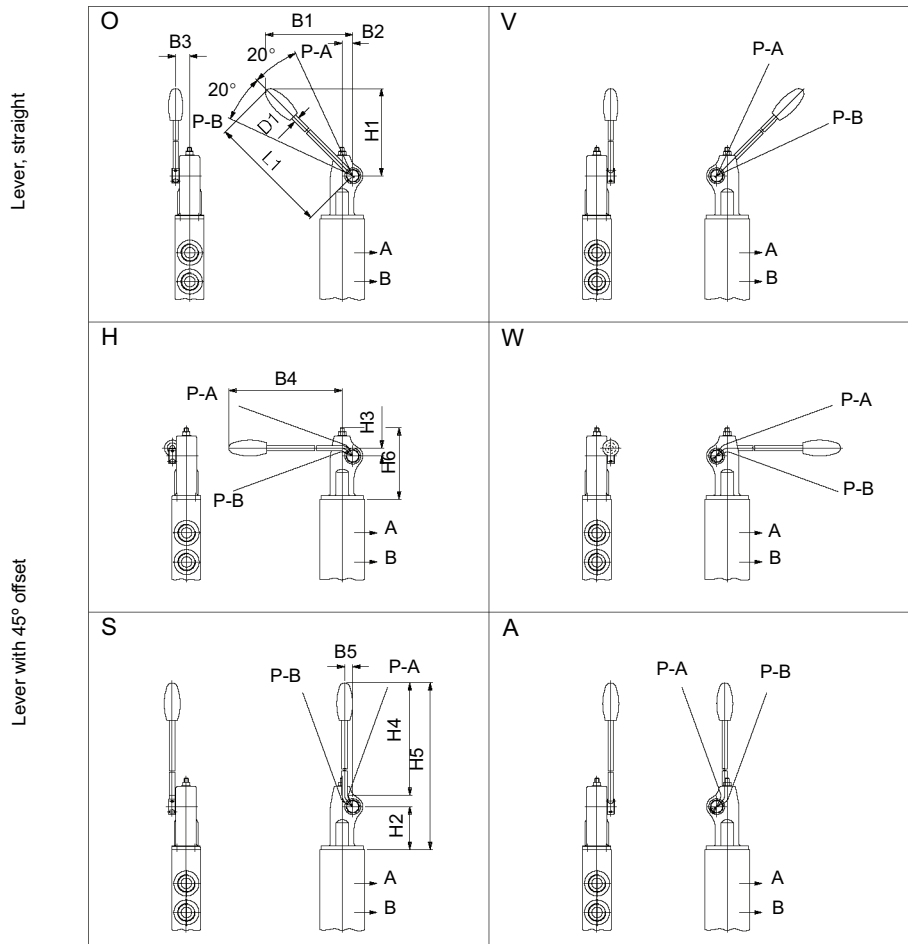

Dimensions													
NG	B1	B2	B3	B4	B5	H1	H2	H3	H4	H5	H6	L1	D1
12	146	14	19.5	194	11.2	148	50.3	11.2	177	245	95	198	8
18	230.5	19.5	28	316	15	232	81.3	15	294	398	135	320	10

## 8.5 Spool symbols

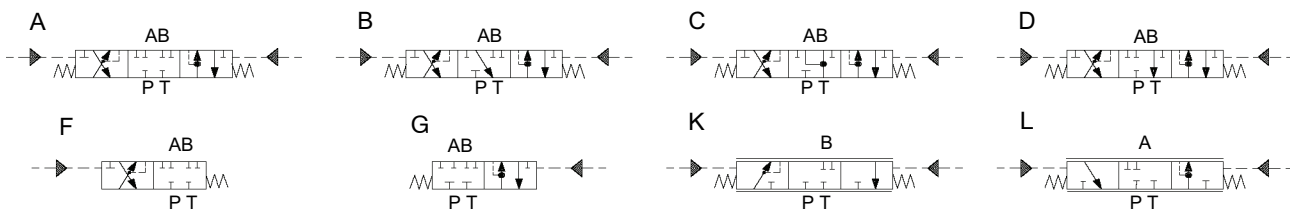

## 9 Dimensions

### 9.1 Valve types

(Fig. 12C... Y00...)

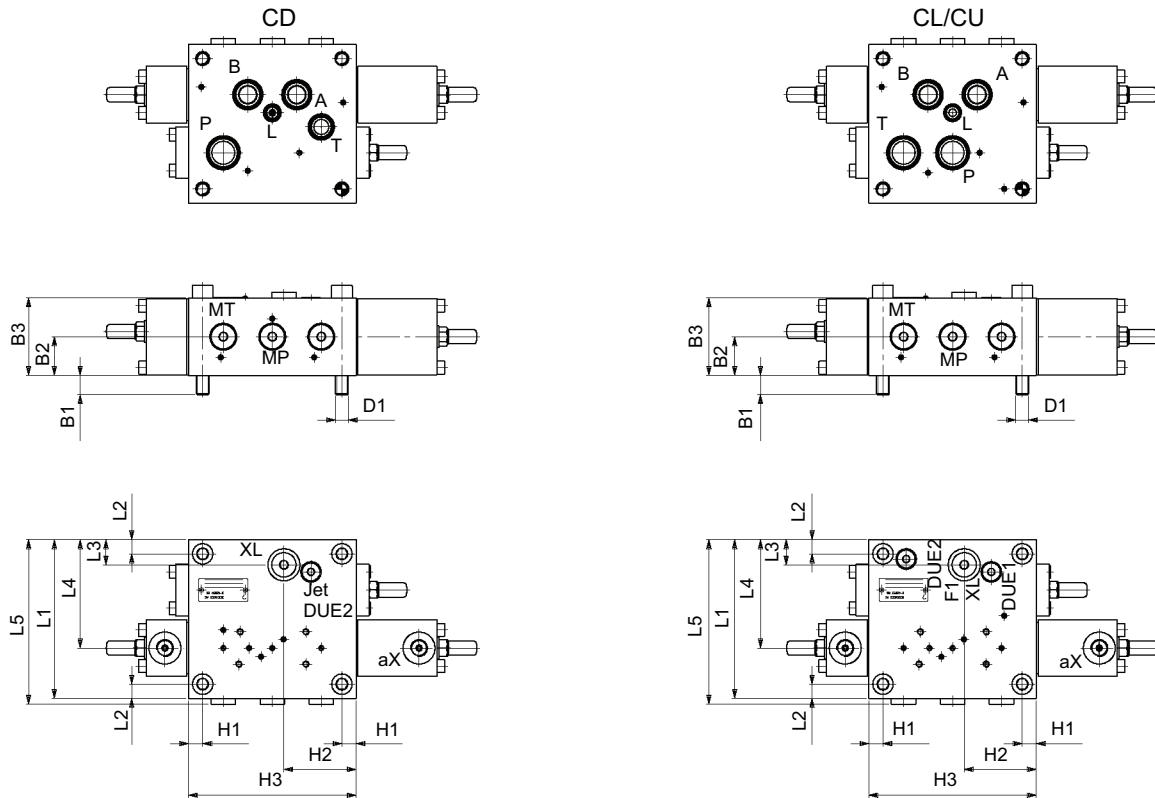

Dimensions														
NG	L1	L2	L3	L4	L5	D1	H1	H2	H3	B1	B2	B3	XL*	MP/MT*
12	123	11	19.5	84	127.5	M10	11	56	130	15	30	60	G ¼	G ¼
18	150	12	24	105	154.5	M12	12	67	180	20	40	80	G ¼	G ½
25	210	15	35	150	214.5	M16	15	45	240	25	55	110	G ¼	G ¾

\* DIN 3852

## 9.2 Valves with actuating methods H6 / H7

### 9.2.1 Valve with actuating method H6

(Fig. 12 CD..H6O..)

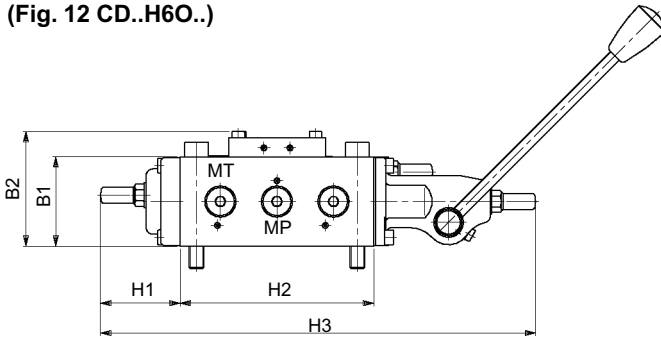

NG	Dimensions				
	B1	B2	H1	H2	H3
12	60	77	53.5	130	292.3
18	80	97	42.5	180	388.3

### 9.2.2 Valve with actuating method H7

(Fig. 12 CD..H7O..)

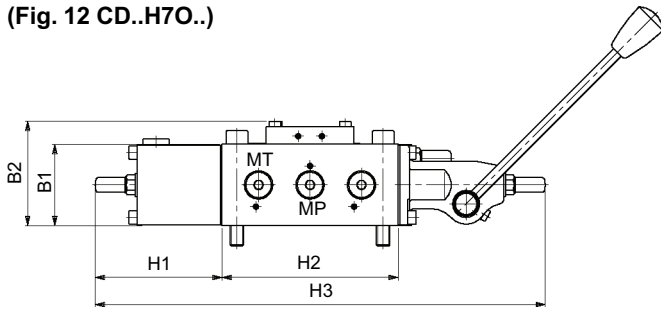

NG	Dimensions				
	B1	B2	H1	H2	H3
12	60	77	93.7	130	332.5
18	80	97	107.5	180	437.6

## 9.3 Valves with actuating methods S1, S2, S3, S4

(Fig. 12 CD..S1O..)

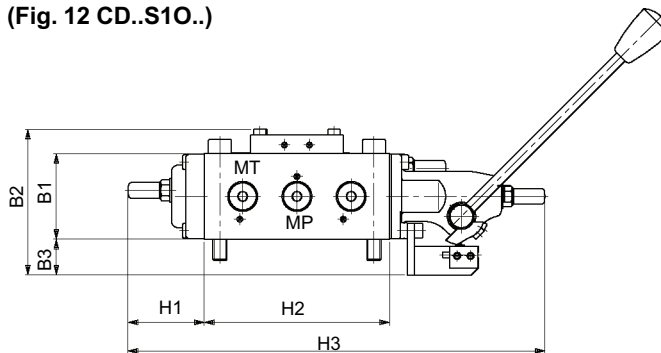

NG	Dimensions					
	B1	B2	B3	H1	H2	H3
12	25	60	102	53.5	130	292.3
18	25.5	80	122.5	42.5	180	388.3

## 9.4 Valves with actuating method Y0

(Fig. 12 CD..Y00..)

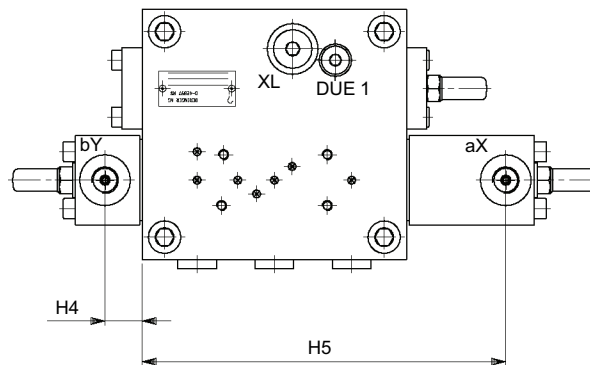
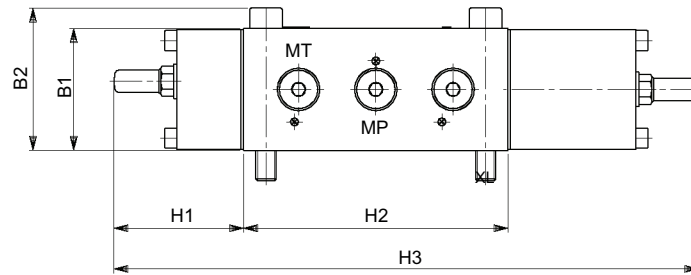

Dimensions									Connecting thread
NG	B1	B2	H1	H2	H3	H4	H5		aX/bX
12	60	70	53.5	130	287.6	18.3	178.8		G 1/4
18	80	92	42.5	180	347.6	13.3	237.3		G 1/4
25	110	126	77.5	240	470	15	328		G 1/4

## 9.5 Valves with actuating method E1/E2 / E7/E8

### 9.5.1 Valve with actuating method E1/E2

(Fig. 12 CD..E10/E20..)

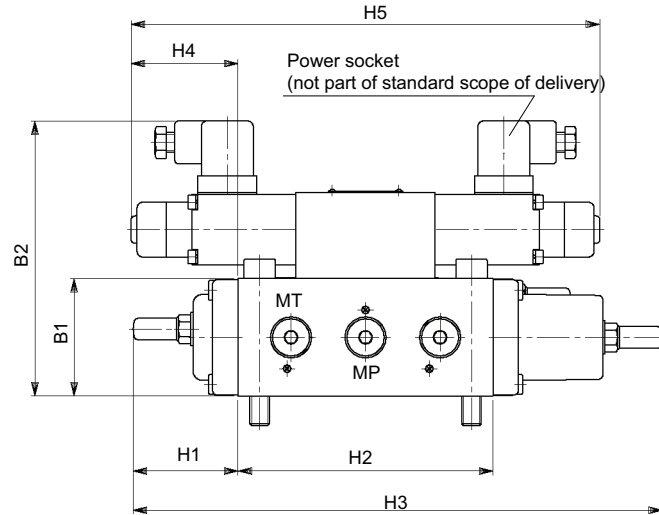

Dimensions								
NG	B1	B2	H1	H2	H3	H4	H5	
12	60	~ 141	53.5	130	292.3	52	appr. 234	
18	80	~ 161	42.5	180	388.3	27	appr. 234	
25	110	~ 191	77.5	240	470	~ 3	appr. 234	

### 9.5.2 Valve with actuating method E7/E8

(Fig. 12 CD..E70/E80..)

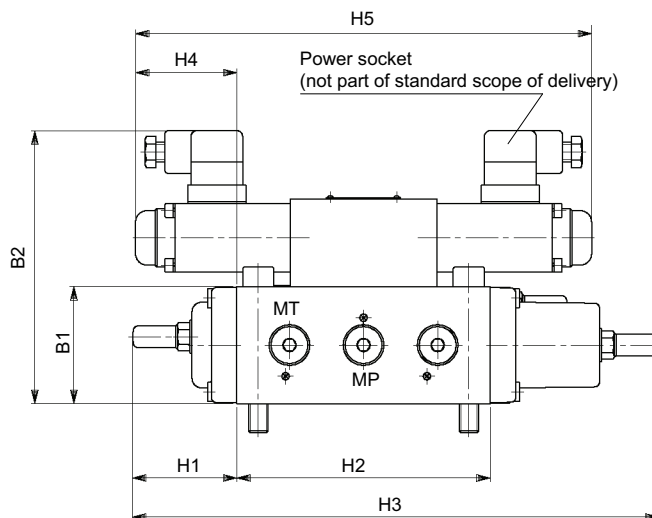

Dimensions								
NG	B1	B2	H1	H2	H3	H4	H5	
12	60	~ 140	53.5	130	292.3	52	234	
18	80	~ 160	42.5	180	388.3	27	234	
25	110	~ 190	77.5	240	470	-3	234	



## 9.6 Valves with actuating method M2(M1) / M3(M4)

### 9.6.1 Valve with actuating method M2(M1)

(Fig. 12 CD..M20(M10)..)

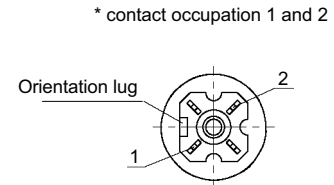
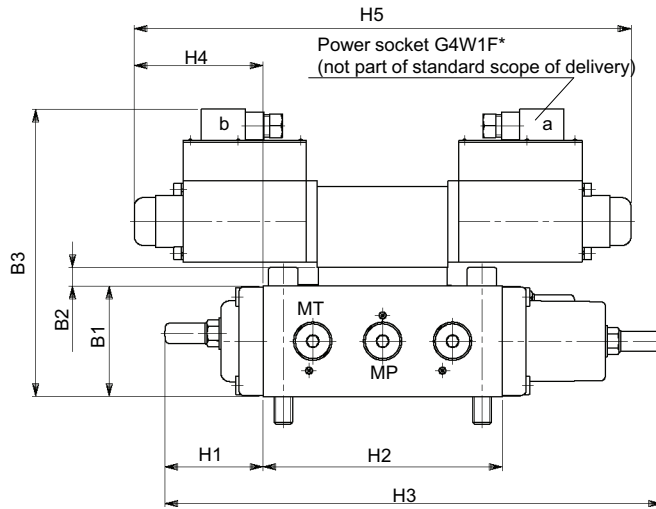

Dimensions									
NG	B1	B2	B3	H1	H2	H3	H4	H5	
12	60	10	156	53.5	130	292.3	70	270	
18	80	10	176	42.5	180	388.3	45	270	
25	110	-	196	77.5	240	470	15	270	

### 9.6.2 Valve with actuating method M3(M4)

(Fig. 12 CD..M30(M40)..)

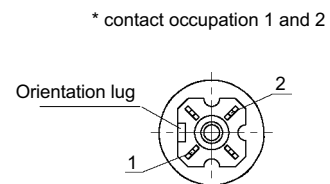
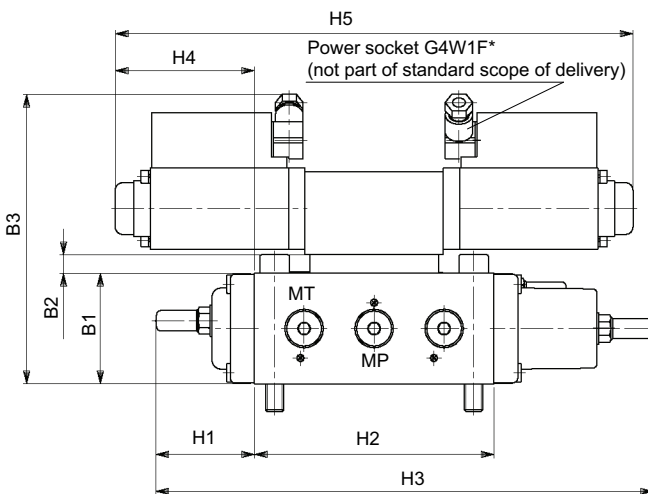

Dimensions									
NG	B1	B2	B3	H1	H2	H3	H4	H5	
12	60	10	~ 157	53.5	130	292.3	75.5	281	
18	80	10	~ 177	42.5	180	388.3	50.5	281	
25	110	-	~ 197	77.5	240	470	20.5	281	

## 9.7 Valves with actuating method M6(M5) / B6(B5)

### 9.7.1 Valve with actuating method M6(M5) on request only

(Fig. 12 CD..M60(M50)..)

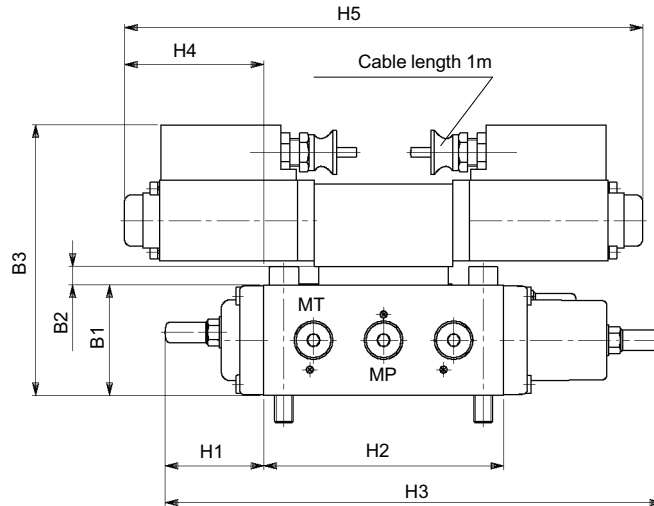

Dimensions									
NG	B1	B2	B3	H1	H2	H3	H4	H5	
12	60	10	~ 147	53.5	130	292.3	75.5	281	
18	80	10	~ 167	42.5	180	388.3	50.5	281	
25	110	-	~ 187	77.5	240	470	20.5	281	

### 9.7.2 Valve with actuating method B6(B5) on request only

(Fig. 12 CD..B60(B50)..)

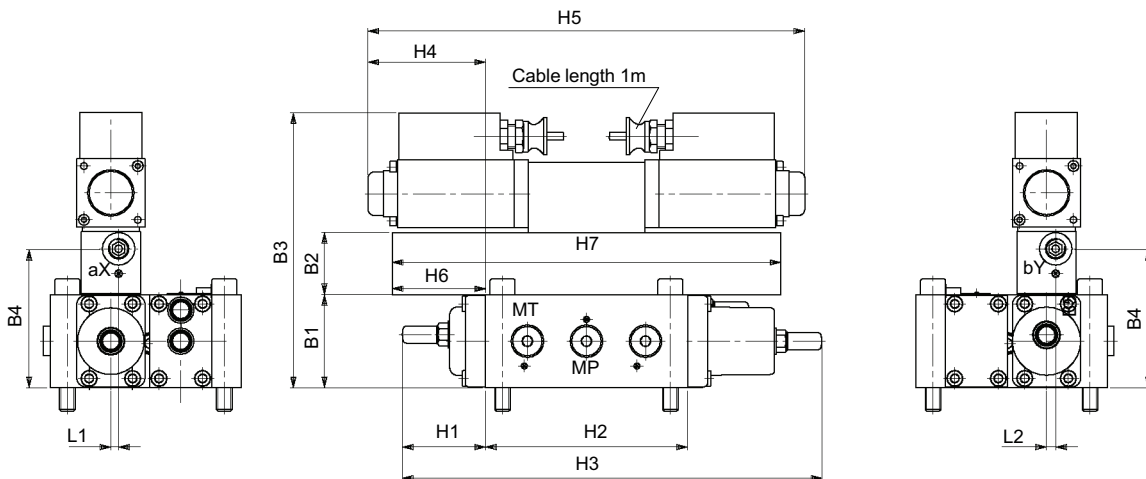

Dimensions														Connecting thread
NG	B1	B2	B3	B4	L1	L2	H1	H2	H3	H4	H5	H6	H7	aX/bX
12	60	40	~ 177	89	5	5.9	53.5	130	292.3	75.5	281	60	250	G ¼
18	80	40	~ 297	109	5	5.9	42.5	180	388.3	50.5	281	35	250	G ¼
25	110	40	~ 227	139	5	5.9	77.5	240	470	20.5	281	5	250	G ¼

## 9.8 Valves with actuating method Y1/Y2 / Y7/Y8

### 9.8.1 Valve with actuating method Y1/Y2

(Fig. 12 CD..Y10(Y20)..)

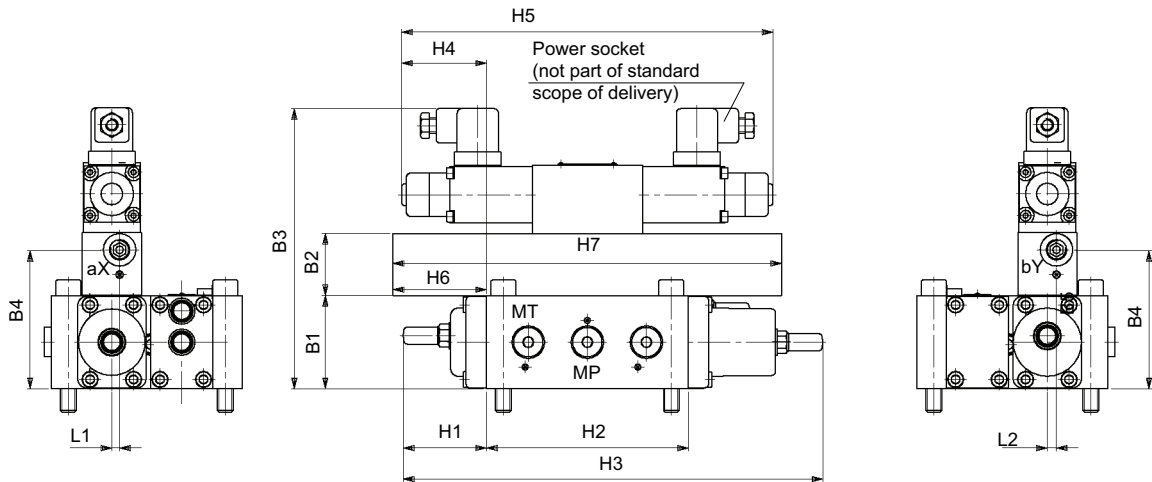

Dimensions													Connecting thread	
NG	B1	B2	B3	B4	L1	L2	H1	H2	H3	H4	H5	H6	H7	aX/bX
12	60	40	~ 40	89	5	5.9	53.5	130	292.3	52	appr. 234	60	250	G ¼
18	80	40	~ 201	109	5	5.9	42.5	180	388.3	27	appr. 234	35	250	G ¼
25	110	40	~ 231	139	5	5.9	77.5	240	470	-3	appr. 234	5	250	G ¼

### 9.8.2 Valve with actuating method Y7/Y8

(Fig. 12 CD..Y70(Y80)..)

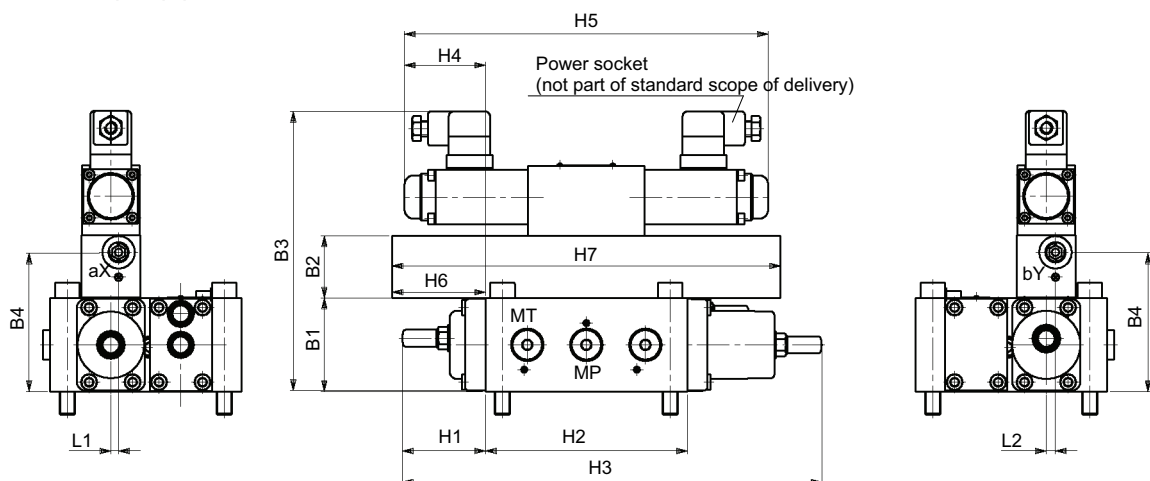

Dimensions													Connecting thread	
NG	B1	B2	B3	B4	L1	L2	H1	H2	H3	H4	H5	H6	H7	aX/bX
12	60	40	~ 180	89	5	5.9	53.5	130	292.3	52	234	60	250	G ¼
18	80	40	~ 200	109	5	5.9	42.5	180	388.3	27	234	35	250	G ¼
25	110	40	~ 230	139	5	5.9	77.5	240	470	-3	234	5	250	G ¼

## 9.9 Valves with actuating method B2(B1) / B3(B4)

### 9.9.1 Valve with actuating method B2(B1)

(Fig. 12 CD..B20(B10)..)

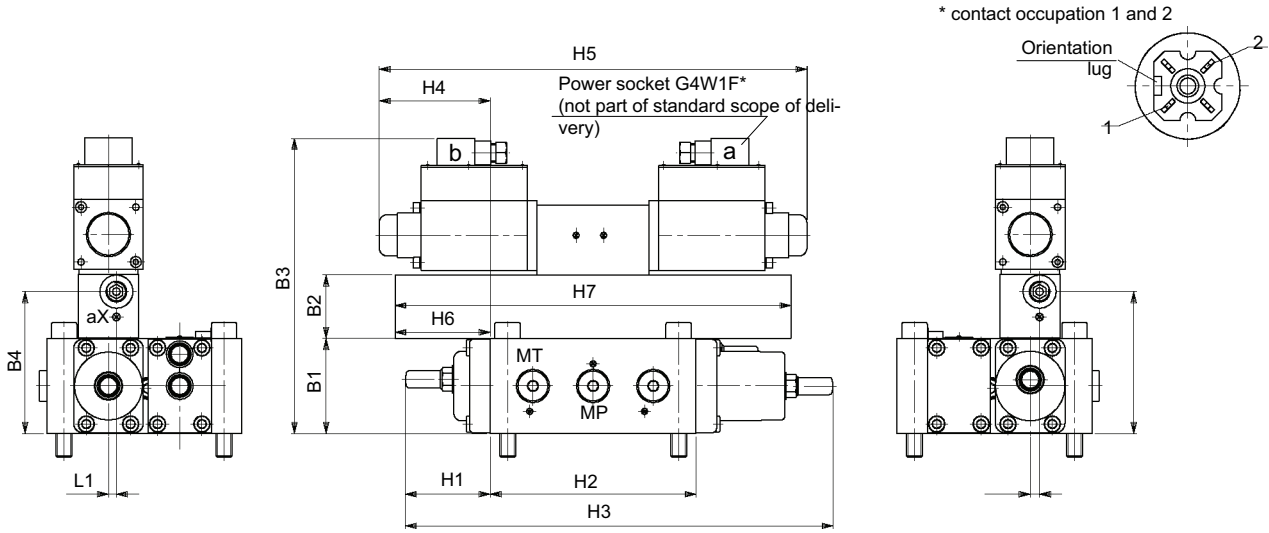

Dimensions														Connecting thread	
NG	B1	B2	B3	B4	L1	L2	H1	H2	H3	H4	H5	H6	H7	aX/bX	
12	60	40	186	89	5	5.9	53.5	130	292.3	60	270	60	250	G ¼	
18	80	40	206	109	5	5.9	42.5	180	388.3	45	270	35	250	G ¼	
25	110	40	236	139	5	5.9	77.5	240	470	15	270	5	250	G ¼	

### 9.9.2 Valve with actuating method B3(B4)

(Fig. 12 CD..B30(B40)..)

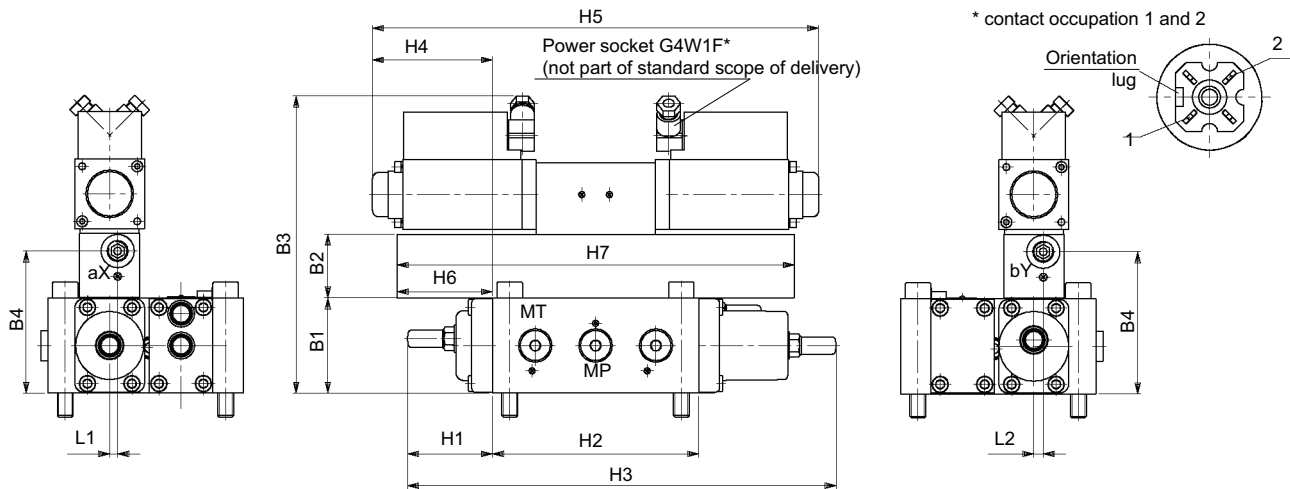

Dimensions														Connecting thread	
NG	B1	B2	B3	B4	L1	L2	H1	H2	H3	H4	H5	H6	H7	aX/bX	
12	60	40	~ 187	89	5	5.9	53.5	130	292.3	75.5	281	60	250	G ¼	
18	80	40	~ 207	109	5	5.9	42.5	180	388.3	50.5	281	35	250	G ¼	
25	110	40	~ 237	139	5	5.9	77.5	240	470	20.5	281	5	250	G ¼	

## 9.10 Valves with actuating method K1/K2 / K8(K5)

### 9.10.1 Valve with actuating method K1/K2

(Fig. 12 CD..K10/K20..)

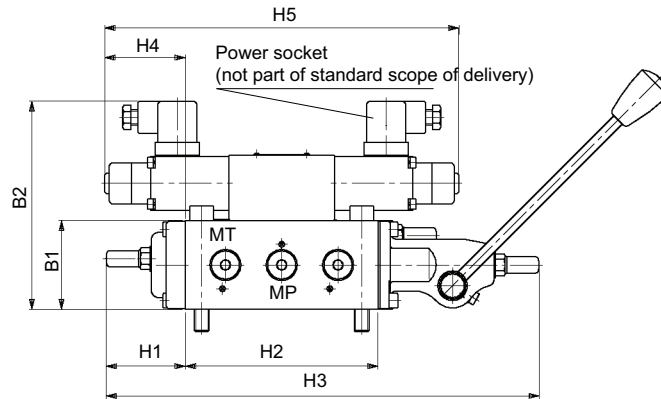

Dimensions							
NG	B1	B2	H1	H2	H3	H4	H5
12	60	~ 141	53.5	130	292.3	52	appr. 234
18	80	~ 161	42.5	180	388.3	27	appr. 234

### 9.10.2 Valve with actuating method K8(K5)

(Fig. 12 CD..K80(K50..))

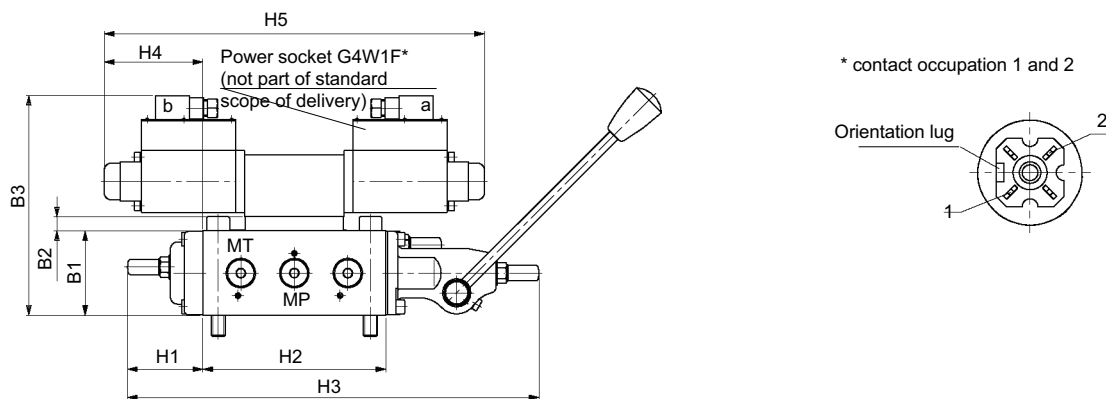

Dimensions								
NG	B1	B2	B3	H1	H2	H3	H4	H5
12	60	10	156	53.5	130	292.3	70	270
18	80	10	176	58.5	180	388.3	45	270

## 9.11 Valves with actuating method K9(K6) / KO(K7)

### 9.11.1 Valve with actuating method K9(K6)

(Fig. 12 CD..K9O(K6O..))

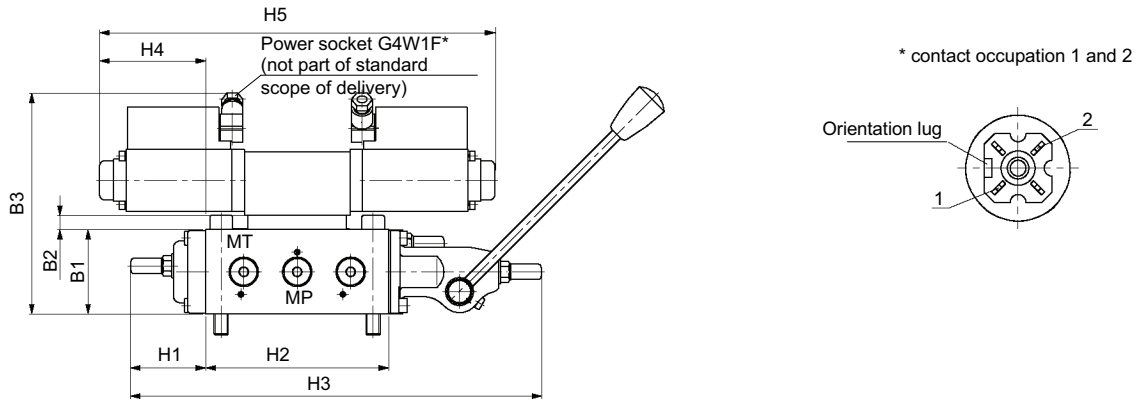

Dimensions									
NG	B1	B2	B3		H1	H2	H3	H4	H5
12	60	10	~ 157		53.5	130	292.3	75.5	281
18	80	10	~ 177		42.5	180	388.3	50.5	281

### 9.11.2 Valve with actuating method KO(K7)

(Fig. 12 CD..K0O(K7O..))

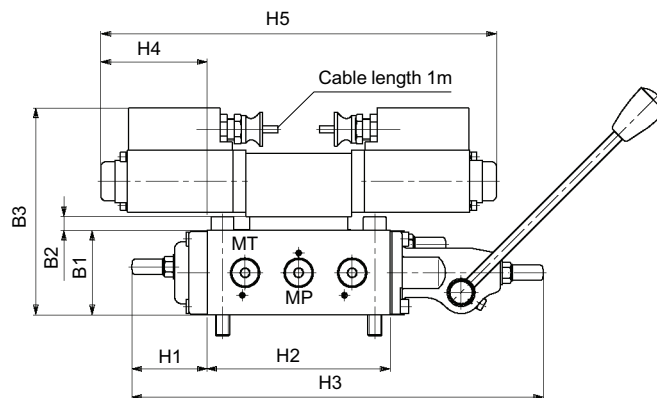

Dimensions									
NG	B1	B2	B3		H1	H2	H3	H4	H5
12	60	10	~ 147		53.5	130	292.3	75.5	281
18	80	10	~ 167		42.5	180	388.3	50.5	281

## 9.12 Valves with actuating method H0

(Fig. 12 CD..H0O..)

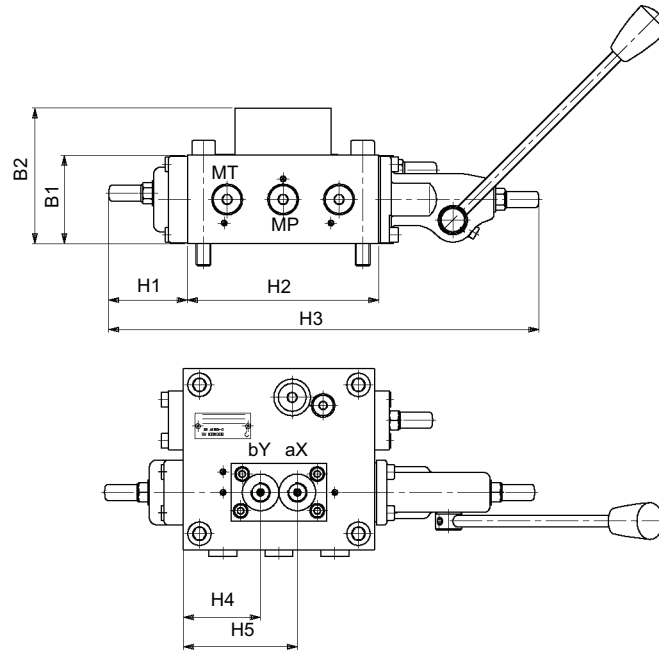

Dimensions									Connecting thread
NG	B1	B2	H1	H2	H3	H4	H5		
12	60	92	53.5	130	292.3	52.5	77.5	G 1/4	
18	80	112	42.5	180	388.3	77.5	102.5	G 1/4	

### 9.13 Connection diagrams

(view on mounting plate)

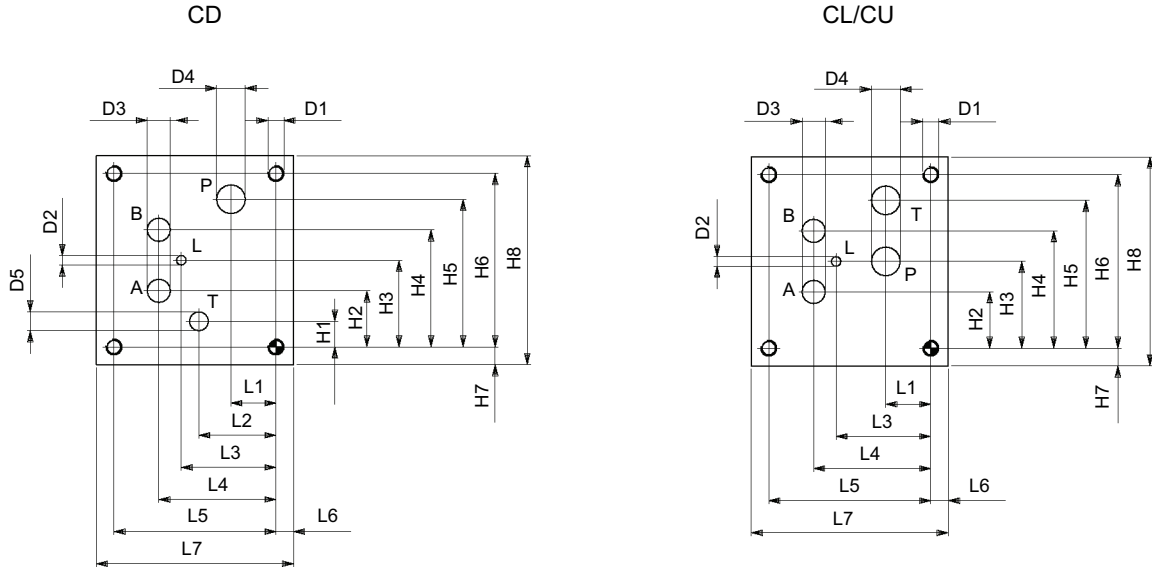

Required surface quality of the mating component:

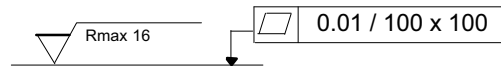

Dimensions												
NG	L1	L2	L3	L4	L5	L6	L7	D1	D2	D3	D4	D5
12	28	48	59	73	101	11	123	M10; min 17 deep	6	14.5	18	11.8
18	33	60	75	93	126	12	150	M12; min 22 deep	6	20.5	25	19.1
25	45	89	110	135	180	15	210	M16; min 27 deep	6	29	35	29

Dimensions									
NG	H1	H2	H3	H4	H5	H6	H7	H8	
12	16	35	54	73	92	108	11	130	
18	31	51	78	105	132	156	12	180	
25	42	68	105	142	179	210	15	240	

[info.rs@bucherhydraulics.com](mailto:info.rs@bucherhydraulics.com)

[www.bucherhydraulics.com](http://www.bucherhydraulics.com)

© 2010 by Bucher Hydraulics Remscheid GmbH, D-42861 Remscheid

All rights reserved.

Data is provided for the purpose of product description only, and must not be construed as warranted characteristics in the legal sense. The information does not relieve users from the duty of conducting their own evaluations and tests. Because the products are subject to continual improvement, we reserve the right to amend the product specifications contained in this catalogue.

Classification: 430.300.