

Electrically Operated Pressure-Relief Cartridge, Size 1 Seated Design, Direct Acting Series WUVA-1LO ...

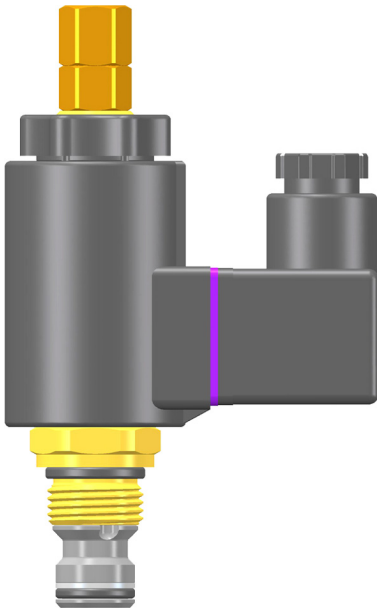

- 1.5 l/min, 420 bar
- Wet-armature solenoid with high-pressure core tube and slip-on coil
- Coils can be changed without opening the hydraulic envelope
- Coils with DIN, Deutsch, Kostal or Junior Timer plug connections can be supplied
- all external parts are chromited and are Cr VI-free
- Suitable for pilot functions
- Can be fitted in a line-mounting body

Their preferred application is as pilot control valves. Any pressure at port 1 on the secondary-pressure side is additive to the valve setting, therefore port 1 should preferably be routed directly to tank. All external parts are chromited (Cr VI-free) and the valves are thus suitable for use in the harshest operating environments. The cartridges can be fitted in the AL cavity and also in some 3/4"-16 UNF cavities from other valve manufacturers. For customers who manufacture their own manifold blocks, we offer form-tool sets for sale or hire. The GALA body with G 3/8" port threads is available for pipe-mounting applications.

1. Description

Series WUVA-1LO... cartridges are screw-in, electrically operated pressure-relief valves, nominal size 1 mm. They are direct-acting seat valves. The mounting thread is the 3/4"-16 UNF pattern.

2. Symbol

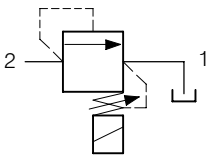

3. Main characteristics

Designation		pressure-relief cartridge	
Design		seat-valve design, direct acting	
Mounting method		screw-in cartridge, 3/4"-16 UNF	
Size		nominal size 1 mm, cavity type AL	
Weight	kg	0.45	
Mounting attitude		unrestricted	
Flow direction		2 → 1, see symbol	
Operating pressure range	in port 2 in port 1	bar	... 420 ... 250
Pressure-setting range		bar	pressure range 42 = ... 420 pressure range 35 = ... 350 pressure range 25 = ... 250 pressure range 16 = ... 160 pressure range 10 = ... 100 pressure range 04 = ... 40
Hydraulic fluid			HL and HLP hydraulic oils to DIN 51 524; for other fluids, please consult BUCHER
Fluid temperature range		°C	-25 ... +80
Ambient temperature		°C	-25 ... +80
Viscosity range		mm ² /s (cSt)	10 ... 650 recommended 15 ... 250
Flow rate Q _{max.}		l/min	1.5, see performance graphs

Minimum fluid cleanliness level		20/18/15 to ISO 4406 : 1999
Nominal voltages	VAC VDC	115, 230, (50...60 Hz) 12, 24
Nominal voltage tolerance	%	± 10
Nominal power consumption	W	VAC = 25, VDC = 27
Relative duty cycle	%	100
Protection class		IP 65 / IP 67, see "Ordering code" (when connector plugs are properly fitted)
Electrical connection		3-pin square plug to DIN EN 175301-803 (standard) for other connectors, see "Ordering code"

4. Performance graphs

measured with oil viscosity 33 mm²/s (cSt)

Type WUVA-1LO-42-1 ...

Δp -Q characteristics

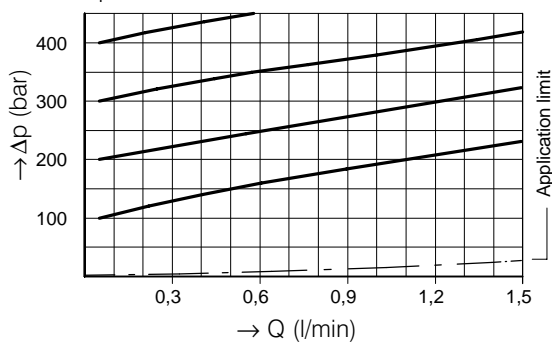

Type WUVA-1LO-35-1 ...

Δp -Q characteristics

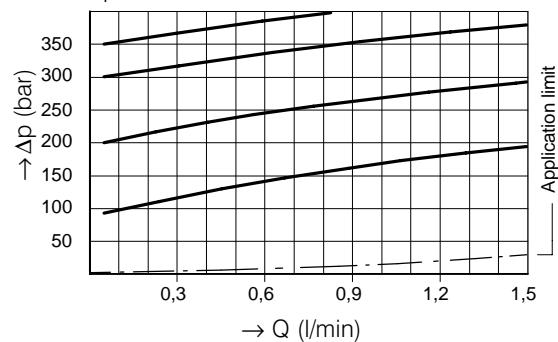

Type WUVA-1LO-25-1 ...

Δp -Q characteristics

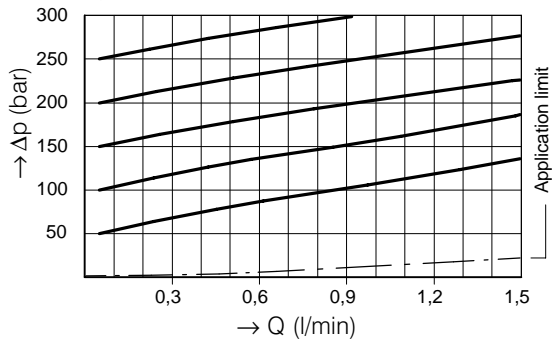

Type WUVA-1LO-16-1 ...

Δp -Q characteristics

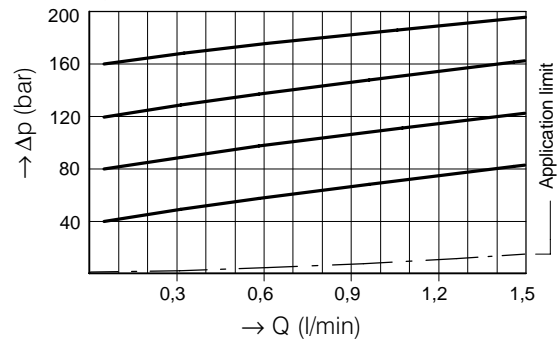

Type WUVA-1LO-10-1 ...

Δp -Q characteristics

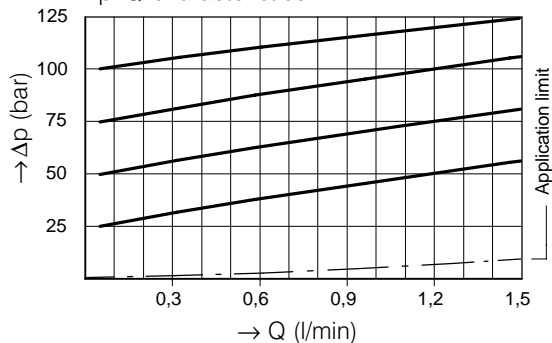

Type WUVA-1LO-04-1 ...

Δp -Q characteristics

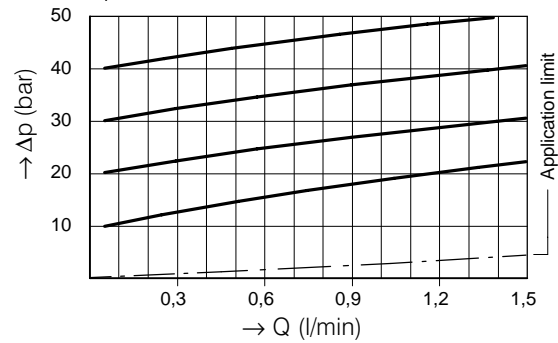

5. Setting the pressures

(pressure p1 must be set first, followed by pressure p2)

Setting the higher pressure p1

with pump running and solenoid energised:

1. Slacken cap nut item 12 and remove it.
2. Slacken lock nut item 11 (13 A/F) approx. 1/2 turn.
3. With pump running and solenoid energised, use the two flats (7 A/F) to turn adjusting screw item 9 until the required pressure is set in 2.
4. Hold the adjusting screw item 9 using the 7 A/F flats while tightening the lock nut item 11 (13 A/F).
5. Refit cap nut item 12 and tighten it.

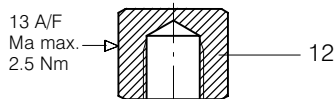

When setting pressure p1, do not over-tighten the adjusting screw item 9 as this can destroy the stop-ring that limits the maximum pressure setting. Stop turning as soon as a definite end-stop can be felt.

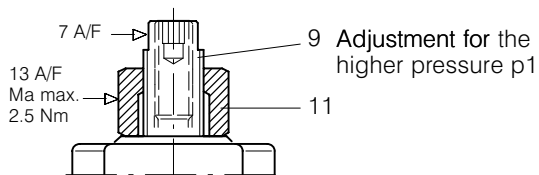

Setting the lower pressure p2

(second relief setting, or vented pressure) with pump running and solenoid de-energised:

1. Slacken cap nut item 12 and remove it.
2. With pump running and solenoid de-energised, use the adjusting screw item 10 (2.5 A/F hex. socket) to set the pressure p2 in 2. (p2 min.: ... 10 bar, dependent on flow rate).
3. Refit cap nut item 12 and tighten it.

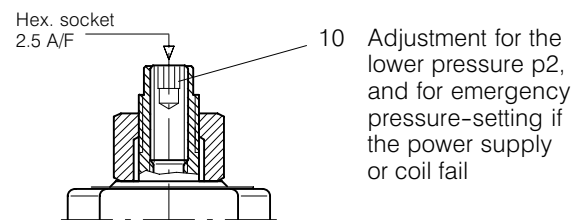
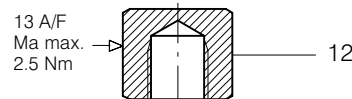

Adjustment for the lower pressure p2, and for emergency pressure-setting if the power supply or coil fail

Example showing the adjustable pressures p1 and p2 (p1 ≥ p2)

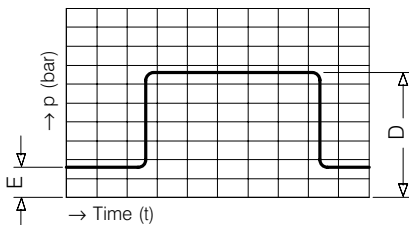

WUVPA ... (ON / OFF)

The relief pressure p1 is set as the higher working pressure (D) (solenoid energised)

p2 is set as a low vented pressure (E) (solenoid is de-energised)

D = pressure p1; as set with item 9, solenoid ON

E = pressure p2; can be set with item 10 to a maximum equal to D, solenoid OFF

6. Dimensions

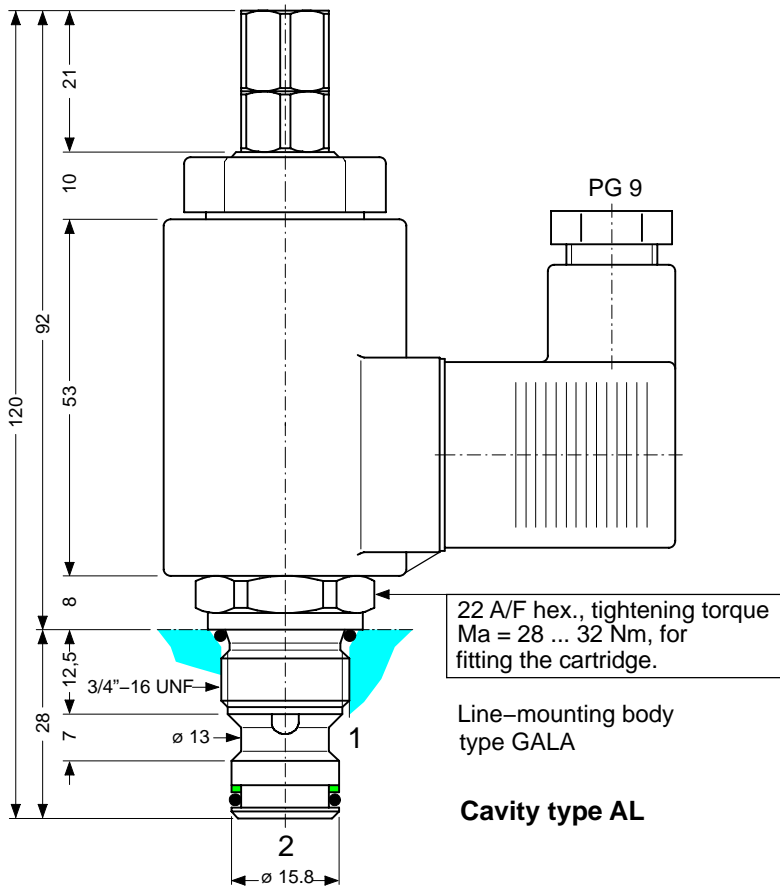

7. Schematic section

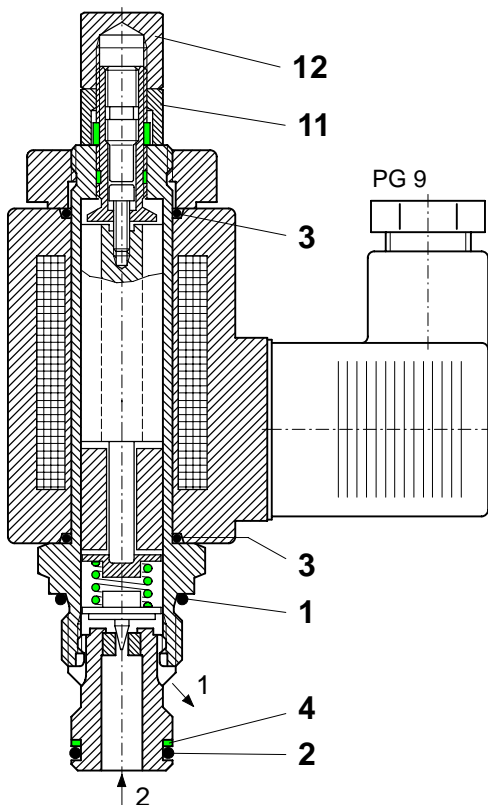

Seal kit no. DS-317, comprising:

lt.	Qty.	Description	Size
1	1	O-ring no. 017	Ø 17.17 x 1.78 N90
2	1	O-ring no. 014	Ø 12.42 x 1.78 N90
3	2	O-ring	Ø 16.00 x 2.00 Viton
4	1	Backup ring	Ø 10.70 x 1.45 x 1.0 FI0751

8. Installation and servicing

All work must be carried out with care and by qualified personnel only. When fitting the cartridge, ensure that the seals are oiled or greased and use the specified tightening torque. When changing seals, oil or grease the new seals thoroughly before fitting them.

9. Ordering code

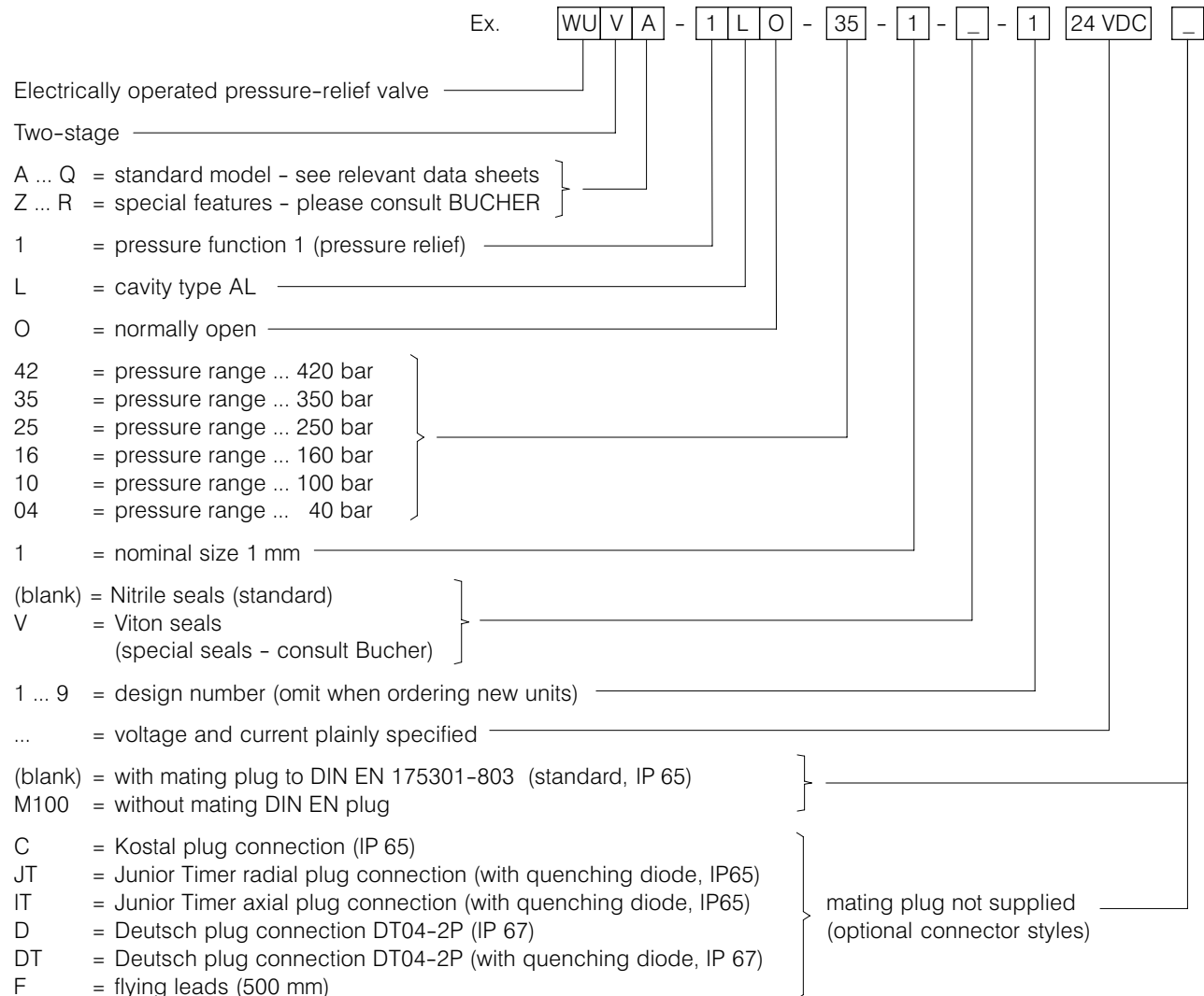

10. Related data sheets

Old no.	New no.	
i-32	400-P-040011-E	The form-tool hire programme
i-33.10	400-P-040171-E	Cavity type AL
W-2.141	400-P-120110-E	Coils for screw-in cartridge valves
G-4.10	400-P-720101-E	Line-mounting body, type GALA (G 3/8")

BUCHER HYDRAULICS

Germany

Phone +49 7742 85 20
Fax +49 7742 71 16
info.de@bucherhydraulics.com

France

Phone +33 389 64 22 44
Fax +33 389 65 28 78
info.fr@bucherhydraulics.com

Netherlands

Phone +31 79 34 26 24 4
Fax +31 79 34 26 28 8
info.nl@bucherhydraulics.com

UK

Phone +44 24 76 35 35 61
Fax +44 24 76 35 35 72
info.uk@bucherhydraulics.com

USA

Phone +1 262 605 82 80
Fax +1 262 605 82 78
info.wi@bucherhydraulics.com

www.bucherhydraulics.com

Switzerland

Phone +41 33 67 26 11 1
Fax +41 33 67 26 10 3
info.ch@bucherhydraulics.com

Italy

Phone +39 0522 92 84 11
Fax +39 0522 51 32 11
info.it@bucherhydraulics.com

Austria

Phone +43 6216 44 97
Fax +43 6216 44 97 4

China

Phone +86 10 64 44 32 88
Fax +86 10 64 44 32 35
info.bj@bucherhydraulics.com

Product Center (Elevator)

Phone +41 41 757 03 33
Fax +41 41 757 16 49
info.nh@bucherhydraulics.com

We reserve the right of modification without notice.