

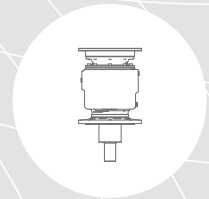

HIGH TECH Cooling

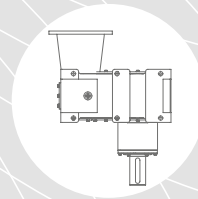

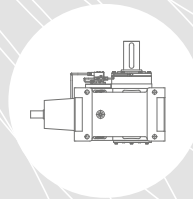

RXO/800/TR

TR - Series

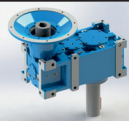

RXP/800/CR

CR - Series

RIDUTTORI PER TORRI DI RAFFREDDAMENTO & CONDENSATORI VENTILATI
GEAR UNITS FOR COOLING TOWER & AIR COOLED CONDENSERS
GETRIEBE FÜR "KÜHLTÜRME" & LUFTGEKÜHLTEN VERFLÜSSIGER

Index



1.1	Caratteristiche costruttive	<i>Construction features</i>	Konstruktionsmerkmale	A4
1.2	Livelli di pressione sonora SPL [dB(A)]	<i>Mean sound pressure levels SPL [dB(A)]</i>	Schalldruckpegel SPL [dB(A)]	A4
1.3	Criteri di selezione	<i>Gear unit selection</i>	Auswahlkriterien	A5
1.4	Verifiche	<i>Verification</i>	Überprüfungen	A5
1.5	Stato di fornitura	<i>Scope of the supply</i>	Lieferzustand	A11
1.6	Normative applicate	<i>Standards applied</i>	Angewendete Normen	A14
1.7	Designazione	<i>Designation</i>	Bezeichnung	A18
1.8	Lubrificazione	<i>Lubrication</i>	Schmierung	A20
1.9	Prestazioni riduttori	<i>Gear unit ratings</i>	Leistungen der Getrieben	A24
1.10	Momenti d'inerzia	<i>Moments of inertia</i>	Trägheitsmomente	A24
1.11	Dimensioni	<i>Dimensions</i>	Applizierbare Motoren	A30
1.12.1	Estremità d'albero entrata	<i>Input shaft end</i>	Ende der Antriebswelle	A31
1.12.2	Estremità d'albero uscita	<i>Output configuration</i>	Ende der Abtriebswelle	A31

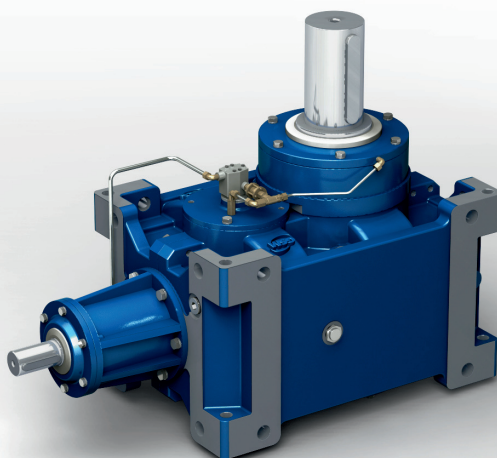

RXO-TR - Cooling Tower

RXP-CR - Air cooled condensers

STM team

STM team

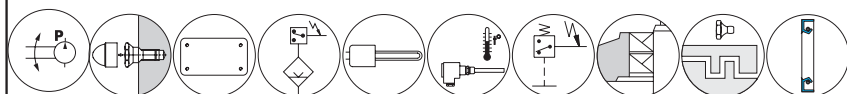

Accessori e opzioni
 Accessories and options
 Zubehör und Optionen

Gestione Revisione Cataloghi GSM
 Managing GSM Catalog Revisions
 Mangement Wiederholt Kataloge GSM

RX
TR&CR



TR - Series





CR - Series

RIDUTTORI PER TORRI DI RAFFREDDAMENTO & CONDENSATORI VENTILATI
 GEAR UNITS FOR COOLING TOWER & AIR COOLED CONDENSERS
 GETRIEBE FÜR "KÜHLTÜRME" & LUFTGEKÜHLTEN VERFLÜSSIGER

STM team
A
 STM team

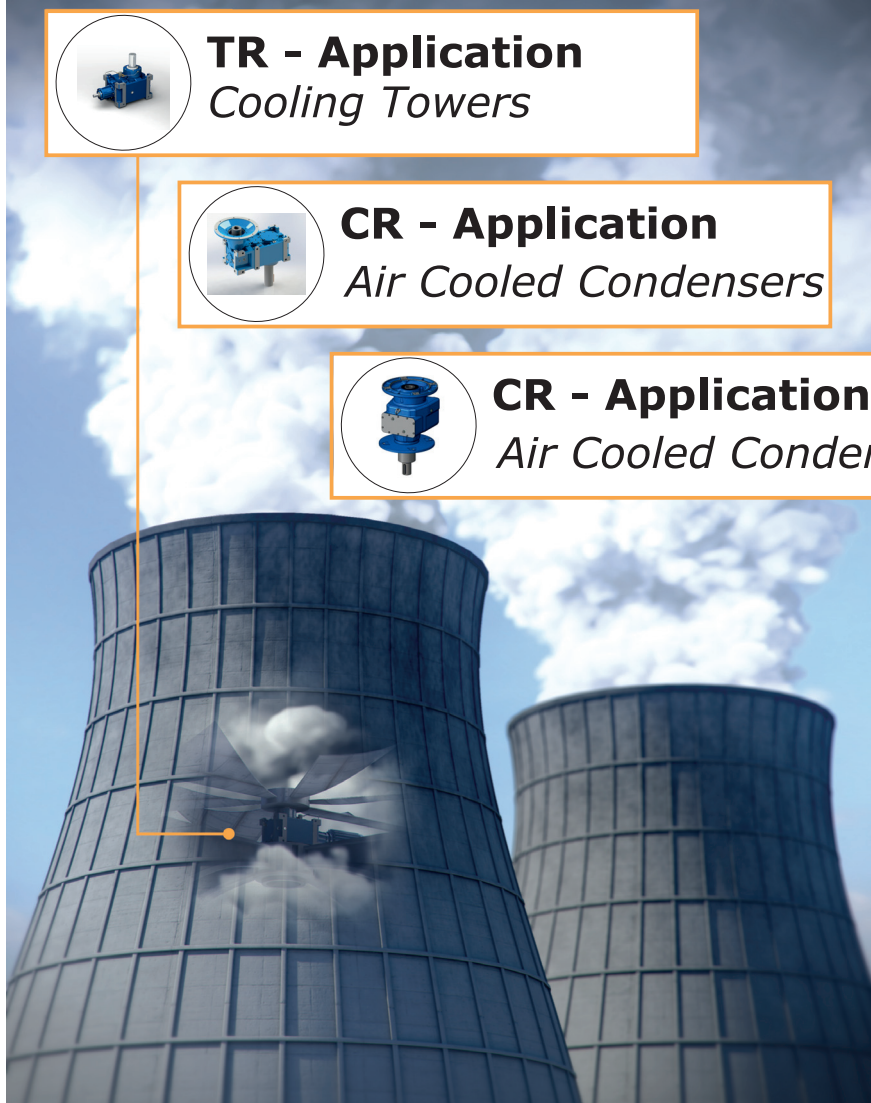
RX - TR & CR - Series



 **TR - Application**
Cooling Towers

 **CR - Application**
Air Cooled Condensers

 **CR - Application**
Air Cooled Condensers

1.0 - Generalità

1.0 General description

1.0 - Allgemeines

Characteristics



Questa serie di riduttori per torri di raffreddamento e condensatori ventilati è una macchina che fa dell'affidabilità la sua caratteristica peculiare, gli ingranaggi ed i cuscinetti largamente dimensionati uniti a un'accurata disposizione interna, distribuiscono i carichi uniformemente giovandone alla durata. Avendo anche la cassa divisa a metà, facilitano il controllo periodico e la eventuale manutenzione soprattutto in luoghi poco agevoli.

These gearboxes series for cooling towers and air cooled condensers is especially built to grant reliability to customers. This is made possible through a generous upsizing of both gears and bearings as well as a balanced internal gear arrangement so to offer optimization of uniformity in balancing loads inside the gearbox.

Die Antriebsreihe für Kühltürme and luftgekühlten verflüssiger and macht die Zuverlässigkeit zu einer ihrer hauptsächlichen Eigenschaften. Die großzügig dimensionierten Zahnräder und Lager kombiniert mit sorgfältiger Anordnung des Innenlebens verteilen die Belastungen gleichmäßig, welche sich auf die Lebensdauer positiv auswirkt. Der geteilte Gehäuseaufbau erleichtert di regelmäßige Inspektion und Wartung vor allem an Orten, die



1.1 Caratteristiche costruttive

1.1 Construction features

1.1 Konstruktionsmerkmale

Characteristics

The Series has been designed for the cooling tower and air cooled condensers environment

I riduttore della serie RX per applicazione TR & CR adottano cuscinetti a rulli di elevata capacità di carico maggiormente distanziati sull'albero e un robusto e rigido supporto esterno, in questo modo è consentito un notevole aumento dei carichi radiali e assiali ammissibili. La solidità costruttiva del riduttore consente di inserirsi in un basso regime di severità vibrazionale. I valori sperimentalmente ottenuti sono riassunti nella tabella sottostante.

The RX series gearboxes for TR & CR application adopt roller bearing with high load capacity, with increased center distance on the shaft and a strong and stiff external support, allowing a considerable increase of radial and axial loads.

Die Getriebe der Baureihe RX für die Anwendung TR & CR setzen Rollenlager mit hoher Tragfähigkeit und mehr Raum zwischen der Welle sowie einer robusten und starren Unterstützung von außen ein; auf diese Art und Weise wird eine erhebliche Erhöhung der Radiallasten und Axialkräfte erlaubt. Die solide Konstruktion ermöglicht das Getriebe in einen niedrigen Vibrationsstärkebereich zu betreiben. Die experimentell erhaltenen Werte sind in der folgenden Tabelle zusammengefasst.

The stiffness of the gearbox allows to place it in a low span of vibration severity. The values experimentally obtained are summarized in the table below.

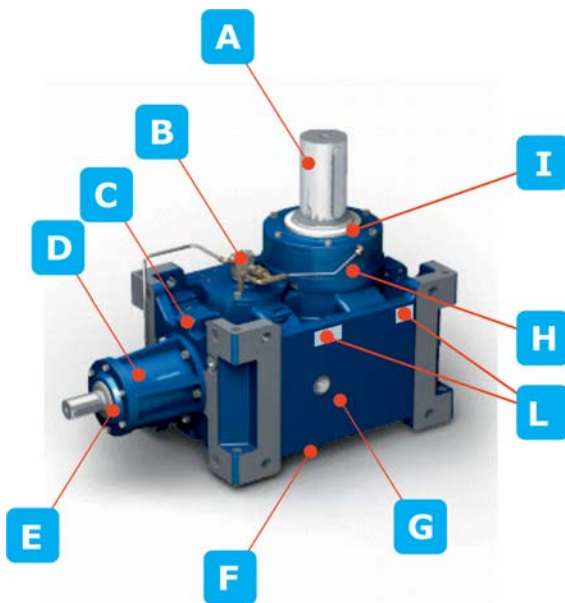

- A High strength to thrust load**
- B Forced lubrication**
- C Increased distance between in/out: reduces vibrations**
- D Optimised gear pairs to reduce the noise**
- E Single oil seals and protection cover**
- F Uniform mounting load**
- G Industrial and marine painting**
- H FEM analysis to minimize the vibrations**
- I Double oil seals and protection cover**
- L Water drains**

Vibration

RXO1 - TR	802	804	806	808	810	812	814	816	818	820	822	824
	1,2 mm/s				1,8 mm/s				2,4 mm/s			
RXO2 - TR	—				814	816	818	820	—			
					1,9 mm/s		2,5 mm/s					

Efficiency

RXO1	802÷812	95
	814÷824	96
RXO2	814÷820	94

Le dimensioni dei nostri riduttori e i rapporti di trasmissione seguono la serie dei numeri normali (serie di RENARD) Ra 20 UNI 2016. 68.

Gear unit dimensions and transmission ratios follow a geometric progression based on the Ra20 series of preferred (or Renard) numbers in accordance with UNI 2016.68.

Die Baugrößen und Übersetzungen unserer Getriebe sind der normalen Nummernserie (RENARD Reihe) Ra 20 UNI 2016.68 gemäß ausgelegt.

L'elevato numero di rapporti di trasmissione $i_N = (4 \div 40)$, consente in alcuni casi di scegliere un riduttore di taglia inferiore.

Our broad range of transmission ratios $i_N = (4 \div 40)$ and high ratio density frequently allows selection of a smaller size. Optimal gear geometry and high machining accuracy ensure low noise levels and higher efficiency:

Die zahlreichen Übersetzungsverhältnisse $i_N = (4 \div 40)$ räumen in einigen Fällen die Möglichkeit ein, ein kleineres Getriebe wählen zu können.

L'ottimizzazione geometrica dell'ingranaggio unitamente ad una accurata lavorazione, assicura bassi livelli di rumorosità e garantisce elevati rendimenti:

Die geometrische Optimierung des Zahnrads verbunden mit einer akkuraten Bearbeitung gewährleistet niedrige Geräuschentwicklung und einen hohen Wirkungsgrad:

1.2 Livelli di pressione sonora SPL [dB(A)]

1.2 Mean sound pressure levels SPL [dB(A)]

1.2 Schalldruckpegel SPL [dB(A)]

Noise

1 Low Noise

3 ~ 5 db (A)
Noise reduction from previous series

2 FEM analysis

Shaft speed reduction achieved using optimised gear pairs, reducing gear noise. Using FEM analysis, deflection under load is minimized and proper gear tooth contact is maintained. FEM model analysis is also performed to minimize natural frequency oscillation.

Valori normali di produzione del livello medio di pressione sonora SPL (dB(A)) a velocità in entrata di 1450 min⁻¹ (tolleranza +3 dB(A)). Valori misurati ad 1 m dalla superficie esterna del riduttore ed ottenuti su elaborazione di prove sperimentali eseguite. Per raffreddamento artificiale con ventola sommare ai valori di tabella: +2 dB(A) per ogni ventola. Per entrata ad un numero di giri diverso sommare i valori come in tabella. Per particolari esigenze è possibile fornire riduttori con livello medio di pressione sonora ridotto.

Noise levels are mean sound pressure levels SPL (dB(A)) and refer to normal operation at an input speed of 1450 rpm (tolerance +3 dB(A)). Measurements are taken at 1 m from the external surface of the gear unit and ratings are obtained by processing test data. For fan-cooled applications, add 2dB(A) to table values for each fan. For different input speeds, add the appropriate values indicated in the table below. Gear units with lower noise levels to suit particular needs are available on request.

Normale Werte des durchschnittlichen Schalldruckpegels SPL (dB(A)) bei einer Antriebsdrehzahl von 1450 U/min (Toleranz +3 dB(A)). Werte, die aus den Auswertungen der erfolgten experimentellen Tests, bei denen die Messung in 1 m Entfernung von der Getriebeoberfläche erfolgte, resultieren. Bei Vorliegen einer Zusatzluftkühlung durch Lüfter muss ein Korrekturwert von +2 dB(A) pro Lüfterrad zum Tabellenwert addiert werden. Bei abweichender Antriebsdrehzahl sind die Werte gemäß Tabellenangaben zu addieren. Im Fall besonderer Anforderungen können Getriebe mit einem reduzierten durchschnittlichen Schalldruckpegel geliefert werden.

	RXO1				RXO2	
	SPL		PWL		SPL	PWL
	i ≤ 14	i > 14	i ≤ 14	i > 14	I<40	I<40
802	76	71	86	81	—	—
804	77	72	87	82	—	—
806	78	73	88	83	—	—
808	79	74	89	84	—	—
810	80	75	90	85	—	—
812	81	76	91	86	—	—
814	83	78	93	88	82	92
816	85	79	95	89	84	94
818	86	80	96	90	86	96
820	87	82	97	92	88	98
822	89	84	99	94	—	—
824	91	86	101	96	—	—

n ₁ [min ⁻¹]	1750	1000	750	550
Δ SPL [dB(A)]	2	-2	-3	-4
Δ PWL [dB(A)]				

SPL - Lp - sound pressure levels
PWL -Lw - sound power levels

Application



1.3 - Applicazioni

Tra le potenziali applicazioni sulle quali può essere installato il riduttori elenchiamo:

- Torri di raffreddamento
- Condensatori ventilati

1.4 - Potential Application

Potential Applications the following are some of the potential applications on which it is possible to install the gearboxes:

- Cooling Towers
- Air cooled condensers

1.4 - Anwendungen

Unter den möglichen Anwendungen, an denen diese Getriebe installiert werden können, möchten wir folgende aufzählen:

- Kühltürme
- Luftgekühlten verflüssiger UFTGEKÜHLTEN VERFLÜSSIGER



Accessories



Possono essere forniti i seguenti accessori e dispositivi

Some devices can optionally be provided

Folgende Zubehörteile und Vorrichtungen können geliefert werden:

Designation

- 1 Cooling**
- 2 Backstop**
- ACC6**
- Bearing lubrication**
- ACC7.**
- 7A** Vibration Sensor
- 7B** Vibration SWITCH
- 7G** OIL LEVEL SWITCH
- 7H** HEATERS
- 7I** PT 100 - SENSOR
- 7M** Pressure switch
- ACC8**
- Sealing**
- OPT**
- Material_Oil seals**

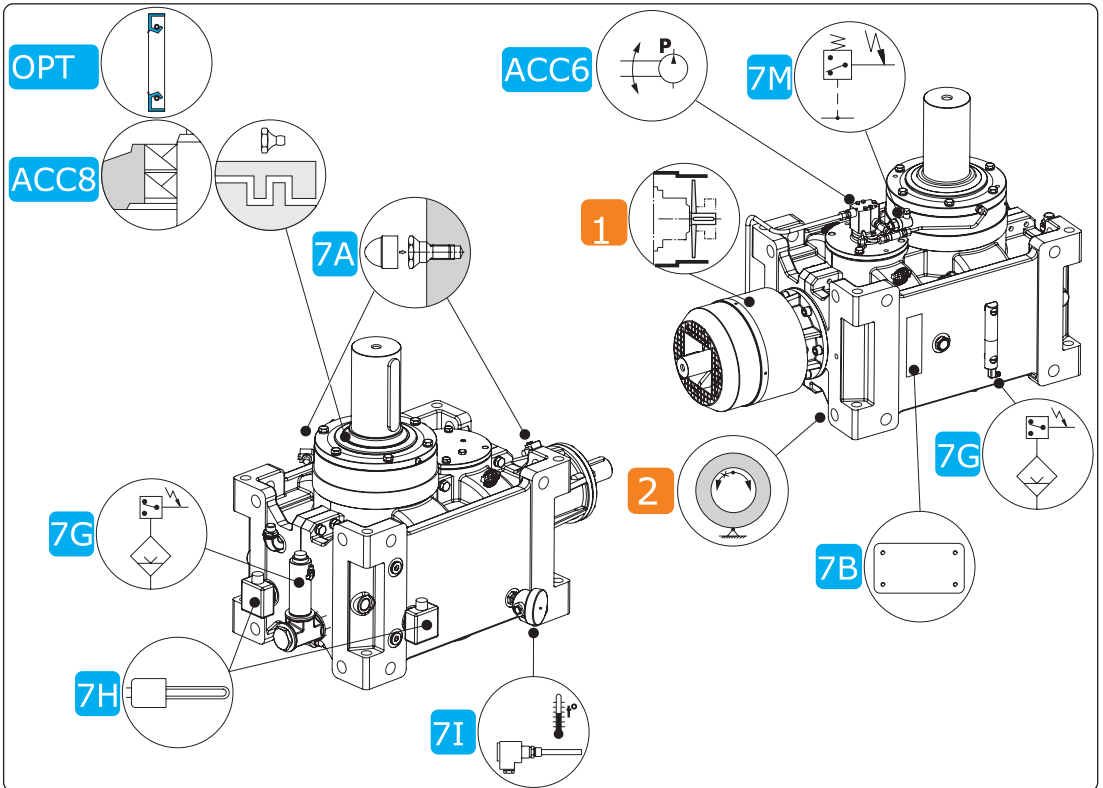

Designation

1 Cooling

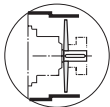

Il calore generato nel riduttore a causa di perdite si può dissipare tramite:
 - raffreddamento naturale attraverso la carcassa
 - raffreddamento supplementare a mezzo ventilatore assiale azionato tramite asse incorporato nel supporto entrata
 Dovrebbe essere sempre garantita l'entrata libera di aria dal lato aspirazione

Heat generated in the gear unit due to losses, can be dissipated by:
 - natural cooling through the housing
 - additional fan cooling, shaft driven axial fan incorporated in the lantern housing
 Free air entry at the suction side should always be guaranteed

Die im Getriebe aufgrund der Leckagen erzeugte Wärme kann folgendermaßen gestreut werden:
 - natürliche Kühlung über den Sitz
 - zusätzliche Kühlung über ein Axialgebläse, das von einer im Sitz der Laterne verbauten Achse angetrieben wird
 Saugseitig sollte stets der freie Lufteinlass gewährleistet sein

ATEX
Disponibile

ATEX
Available

ATEX
Verfügbar

2 Backstop



I dispositivi antiretro sono forniti con capacità di carico idonea alla prestazine del riduttore. Sono montati direttamente sugli assi pignone. La lubrificazione avviene con olio del riduttore.

Backstops are supplied with appropriate load capacity for gear unit rating. They are fitted directly on the pinion shafts. Lubrication is provided by gear unit oil.

Die Rücklaufschutzvorrichtungen werden mit einer für die Klassifizierung des Getriebes geeigneten Belastungsfähigkeit geliefert. Sind direkt an den Ritzelachsen montiert. Die Schmierung erfolgt durch das Getriebeöl.

ATEX
Disponibile

ATEX
Available

ATEX
Verfügbar

ACC6

Bearing lubrication

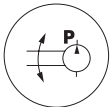

La lubrificazione dei cuscinetti sopra al livello dell'olio è garantita come segue:
 - Grasso
 - Olio
 ATEX – sono forniti con cuscinetti lubrificati a grasso.

The lubrication of the bearings above oil level is ensured as follows:
 - Grease
 - Oil
 ATEX - are supplied with grease lubricated bearings.

Die Schmierung der Lager, über den Ölfüllstand hinaus, wird folgendermaßen gewährleistet:
 - mit Fett
 - mit Öl
 ATEX – werden mit fettgeschmierten Lagern geliefert.

Per le condizioni di consegna fare riferimento alla sezione specifica.

For the delivery conditions refer to the specific paragraph.

Bezüglich der Lieferbedingungen ist Bezug auf den spezifischen Abschnitt zu nehmen.

Accessories

ACC7.

Possono essere forniti i seguenti accessori e dispositivi

Some devices can optionally be provided:

Folgende Zubehörteile und Vorrichtungen können geliefert werden:

7A Vibration Sensor

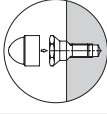

Predisposizione per installazione sensori di vibrazioni. La predisposizione è disponibile sia in ingresso che in uscita

Connection for vibration sensor installation. The connection is available as both input and output

Auslegung für die Installation der Schwingungssensoren. Diese Auslegung ist sowohl am Ein- als auch am Ausgang verfügbar

7B Vibration SWITCH

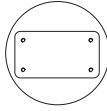

Predisposizione per installazione "Vibration Switch"

Connection for "Vibration Switch" installation

Auslegung für die Installation eines „Vibration Switch“

7G OIL LEVEL SWITCH

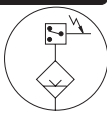

Per controllare il livello dell'olio nel riduttore, può essere fornito uno switch di livello olio. Lo switch può far scattare un allarme quando il livello dell'olio scende al di sotto di un valore specifico

To control the oil level in the gear unit, an oil level switch can be provided. The switch can trigger an alarm signal when the oil level falls beneath a specified

Für die Füllstandkontrolle des sich im Getriebe befindlichen Öls kann ein Ölfüllstandschalter geliefert werden. Dieser Schalter kann einen Alarm auslösen, sobald der Ölfüllstand unter einen bestimmten Wert sinkt

7H HEATERS

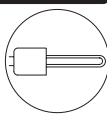

Dispositivi elettrici riscaldamento per avviamenti a basse temperature

Electrical heating devices for low temperature start-up

Elektrische Heizvorrichtungen für Starts bei niedrigen Temperaturen

7I PT 100 - SENSOR

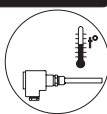

Per controllare la temperatura bagno olio. Il Pt100 può attivare un segnale d'allarme quando la temperatura dell'olio è superiore al limite specificato

To control the oil bath temperature. The Pt100 can trigger an alarm signal when the oil temperature is higher than a specified limit

Für die Kontrolle der Ölsumpftemperatur. Der Pt100 kann ein Alarmsignal auslösen, wenn die Öltemperatur über den vorgegebenen Grenzwert ansteigt

7M Pressure switch

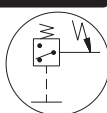

Per controllare la pressione dell'olio, può essere fornito un pressostato / trasmettitore di pressione. Possono attivare un segnale d'allarme quando la pressione scende al di sotto di un limite specifico.

To control the oil pressure, a pressure switch transmitter can be provided. They can trigger an alarm signal when the oil pressure falls beneath a specified limit.

Für die Öldruckkontrolle kann ein Druckschalter / Druckgeber geliefert werden. Diese können ein Alarmsignal auslösen, wenn der Druck unter den vorgegebenen Grenzwert sinkt.

ACC8

Sealing

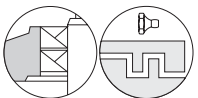

E' possibile richiedere diverse tipologie costruttive per realizzare la tenuta dinamica del riduttore.

It is possible to request various types of manufacturing to ensure the dynamic tightness of the gearbox.

Es können verschiedene Bauarten angefordert werden, um die dynamische Dichtigkeit des Getriebes zu erhalten.

OPT

Material_Oil seals

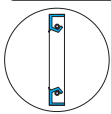

E' possibile richiedere materiali opzionali per gli anelli per la tenuta dinamica del riduttore.

It is possible to request optional materials for the dynamic tightness of gearbox seal rings.

Es können Dichtringe aus optionalen Materialien für die dynamische Dichtigkeit des Getriebes angefordert werden.

Maggiori informazioni sui dispositivi opzionali ACC6-ACC7-ACC8-OPT sono menzionati nella « Sezione U » separata

More detail about the optional devices ACC6-ACC7-ACC8-OPT is mentioned in separate « Section U »

Weitere Informationen zu den optionalen Vorrichtungen ACC6-ACC7-ACC8-OPT werden im getrennten « Abschnitt U » erwähnt



1.3 Criteri di selezione

1.3 Gear unit selection

1.3 Auswahlkriterien

Selection

Conosciuti i dati dell'applicazione calcolare:

$$ir = n_1/n_2 ;$$

$$P1 = \frac{T_{2n} \times n_2 \times 100}{9550 \times RD\%} ;$$

n_1 - Velocità albero entrata;
 n_2 - Velocità albero uscita;
 ir - Rapporto di trasmissione;
 95 - Valore del rendimento dinamico;
 $P1$ - Potenza macchina motrice;

T_{2n} - Coppia Uscita Nominale Applicazione

Per selezionare il riduttore è necessario che sia soddisfatta la seguente relazione:

Potenza Power Leistung	$P_N \geq P_1$
---	----------------

Coppia Torque Drehmoment	$T_N \geq T_{2n}$
---	-------------------

Locate application information and determine:

$$ir = n_1/n_2 ;$$

$$P1 = \frac{T_{2n} \times n_2 \times 100}{9550 \times RD\%} ;$$

n_1 - Input shaft speed;
 n_2 - Output shaft speed;
 ir - Ratio;
 95 - Value of dynamic efficiency;
 $P1$ - Input power;
 T_{2n} - Application nominal output torque

For gearbox selection the following is necessary:

Sind die Daten der Anwendung bekannt, ist wie folgt zu kalkulieren:

$$ir = n_1/n_2 ;$$

$$P1 = \frac{T_{2n} \times n_2 \times 100}{9550 \times RD\%} ;$$

n_1 -Drehzahl Antriebswelle;
 n_2 - Drehzahl Abtriebswelle;
 ir - Übersetzung;
 95 - Die Werte der dynamischer Wirkungsgrad;
 $P1$ - Antriebsleistung;
 T_{2n} - Effektivmoment

Für die Getriebeauswahl ist folgendes zu beachten:

1 Fast Selection

Use the chart to find the RX - size based on motor power and fan speed and ratio gearbox.

1750	Fan speed	440	392	349	311	277	247	220	196	175	156	139	124	110	98	88	78	70	62	55	49	44		
	ir	4,0	4,5	5,0	5,6	6,3	7,1	7,9	8,9	10,0	11,2	12,6	14,1	15,8	17,8	20,0	22,4	25,1	28,2	31,6	35,5	39,8		
M o t o r	8																							
	9																							
	11																							
	15																							
	19																							
	22																							
	30																							
	37																							
	45																							
	55																							
	75																							
	90																		RX02	RX02	RX02			
	110																		RX02	RX02	RX02	RX02	RX02	RX02
	132																		RX02	RX02	RX02	RX02	RX02	RX02
	160																		RX02	RX02	RX02	RX02	RX02	RX02
	200																		RX02	RX02	RX02	RX02	RX02	RX02
	225																		RX02	RX02	RX02	RX02	RX02	RX02
	250																		RX02	RX02	RX02	RX02	RX02	RX02
	280																							
	315																							
355																								
400																								
450																								
500																								
560																								
630																								
710																								
800																								
900																								
1000																								

RX01	802	804	806	808	810	812	814	816	818	820	822	824
RX02	-	-	-	-	-	-	814	816	818	820	-	-

Selection



1.3 Criteri di selezione

Il valore di T_N è riportato nelle schede tecniche di prodotto.

In quanto membro del "COOLING TECHNOLOGY INSTITUTE" la GSM ha realizzato i riduttori della serie TR in conformità a quanto prescritto dall "CTI CODE TOWER-STD-111".

I dati riportati a catalogo non necessitano di essere moltiplicati per ulteriori fattori di servizio per soddisfare alle specifiche di durata e resistenza prescritte nella suddetta norma.

Per n° avviamento/h uguale a 1 non sono necessarie verifiche altrimenti per N° avviamenti/h >1 consultare il nostro servizio tecnico.

Per ulteriori approfondimenti vedere capitolo: " 1.6 Normative applicate".

Scegliere il rapporto, la grandezza, l'esecuzione, la forma costruttiva e verificare le dimensioni del riduttore e di eventuali accessori o particolari estremità.

1.3 Gear unit selection

The T_N value is write on the product technical sheets.

As member of the "COOLING TECHNOLOGY INSTITUTE", GSM has developed the TR solution series according the requirements of "CTI CODE TOWER-STD-111".

The data listed on the catalogue don't need to be multiplied by additional duty factors to meet specifications of lifetime ans strength requested by above mentioned standard.

If start-up no./h is equal to 1, no test is needed; otherwise, if start-up no./h >1, refer to our technical service.

For further details see chapter: "1.6 Compliance with standards"

Select ratio, size, shaft arrangement and design configuration and then check the dimensions of gear unit and any accessories or particular input/output configurations you have selected.

1.3 Auswahlkriterien

Den Wert von T_N finden sie auf den technischen Produkt-Datenblättern

Als Mitglied des "COOLING TECHNOLOGY INSTITUTE" hat GSM die Getriebe der TR-Serie in Übereinstimmung mit den Anforderungen von "CTI CODE TOWER-STD-111" realisiert.

Die im Katalog angegebenen Daten brauchen nicht mit zusätzlichen Service-Faktoren multipliziert werden um die Spezifikationen der Dauer und Widerstandsfähigkeit in der oben genannten und vorgeschriebenen Norm zu erfüllen.

Bei Anz. Starts/h gleich 1 sind keine Überprüfungen erforderlich, andernfalls ist bei Anz. Starts/h >1 unser Technischer Kundendienst zu Rate zu ziehen.

Für weitere Details siehe Kapitel: " 1.6 Einhaltung der Standards".

Die Übersetzung, Größe, Ausführung sowie Bauform wählen und die Größe des Getriebes und des eventuellen Zubehörs oder besondere Wellenenden überprüfen.

1.4 Verifiche

1.4 Verification

1.4 Überprüfungen

01 4) Numero massimo e minimo di giri in entrata $n_{1\max} - n_{1\min}$

4) Check maximum and minimum input speed $n_{1\max} - n_{1\min}$

4) Max. und Min. Antriebsdrehzahl $n_{1\max} - n_{1\min}$

RX01-TR	Sizes	$i < 13,5$	$13,6 < i < 19,7$	$i > 19,8$
$n_{1\min} - [\text{rpm}]$	802-804-806	No Limit		
	808	550	830	1150
	810	550	830	1150
	812	550	830	1150
	814	550	830	1150
	816	750	1150	1500
	818	750	1150	1500
	820	750	1150	1500
	822	550	830	1500
	824	550	830	1500
$n_1 < n_{1\min} - [\text{rpm}]$ $n_1 > 1800 [\text{rpm}]$	802-804-806-808-810-812 814-816-818-820-822-824	Consultare il ns. servizio tecnico commerciale - <i>Please contact our Sales Engineers -</i> Bitten wir Sie sich mit unseren Technischen Kundendienst in Verbindung zu setzen		

RX02-TR	Sizes			$i > 19$
$n_{1\min} - [\text{rpm}]$	814	—	—	960
	816			960
	818			960
	820			960
$n_1 < n_{1\min} - [\text{rpm}]$ $n_1 > 1800 [\text{rpm}]$	814-816-818-820	Consultare il ns. servizio tecnico commerciale - <i>Please contact our Sales Engineers -</i> Bitten wir Sie sich mit unseren Technischen Kundendienst in Verbindung zu setzen		

1.4 Verifiche

02 2) Verifica carichi radiali e assiali

2.1) Albero Entrata

Qualora il collegamento tra riduttore e macchina motrice sia effettuato con mezzi che generano carichi radiali sull'estremità d'albero veloce o lento, occorre fare le seguenti verifiche.

Calcolo Fr_1'

I carichi massimi Fr_1 sono calcolati con a una distanza dalla battuta dell'albero di 0.5 S.

Tali valori sono riportati nelle tabelle delle prestazioni.

Per distanze variabili tra 0 e una distanza "X" bisogna utilizzare la tabella seguente: Fr_1 con coefficiente B.

$$Fr_1' = Fr_1 \cdot \left(\frac{B}{B + X - \frac{S}{2}} \right)$$

Fr_1' [N]	Carico radiale ammissibile su albero entrata alla distanza X	Permissible input shaft OHL at distance X	An Antriebswelle auf Distanz X zulässige Radialkraft
Fr_1 [N]	Carico radiale ammissibile su albero entrata indicato a catalogo	Input shaft OHL capacity as per catalogue rating	An Antriebswelle gemäß Katalogangaben Radialkraft zulässige
X [mm]	Distanza dalla battuta dell'albero	Distance from shaft shoulder	Distanz vom Wellenansatz
S [mm]	Sporgenza dell'albero entrata	Input shaft projection	Überstand der Antriebswelle
B	Coefficiente da tabella	Load location factor from table	Koeffizient aus Tabelle

	Size	802	804	806	808	810	812	814	816	818	820	822	824
B	RX01-TR	67	75	82	90	100	109	120	133	147	164	184	205
	RX02-TR	—						100	109	120	133	—	

B

Coefficienti correttivi del carico radiale di catalogo in entrata Fr_1 in funzione della distanza dalla battuta
Load location factors to adjust input OHL capacity rating Fr_1 based on distance from shoulder

1.4 Verification

2) Overhung and thrust load verification

2.1) Input Shaft

When a gear unit is connected to prime mover machine using overhung drive members that place a radial load on input or output shaft end, check the following loads.

Fr_1' calculation

Load capacity ratings Fr_1 consider a load location at a distance from shaft shoulder of 0.5 S for input shafts.

These values are reported in the rating tables.

Where load is applied at a distance from shoulder between 0 and an "X" distance, refer to the following tables: Fr_1 with load location factor B.

1.4 Überprüfungen

2) Überprüfung der Radial- und Axialkräfte

2.1) Antiebswelle

Erfolgt die Verbindung zwischen Getriebe und Kraftmaschine mit Vorrichtungen, die Radialkräfte auf das Ende der Antriebs- oder Abtriebswelle ausüben, sind folgende Überprüfungen erforderlich.

Berechnung von Fr_1'

Die maximalen Belastungskräfte Fr_1 werden auf einem Abstand vom Wellenansatz von 0.5 S im Fall der Antriebswelle berechnet.

Diese Werte werden in den Leistungstabellen angegeben.

Bei zwischen 0 und einer Distanz "X" variierenden Abständen müssen folgende Tabellen verwendet werden: Fr_1 mit Koeffizient B.

Condizioni applicative necessarie

$$Fa_{input} \leq Fr_1 \times 0,2;$$

$$Fr_{input} \leq Fr_1$$

Fa_{input} - carico assiale generato dalla macchina motrice;
 Fr_{input} - carico radiale generato dalla macchina motrice;

I valori di Fr_1 ed Fa_1 possono essere applicati contemporaneamente.

Necessary conditions for application

$$Fa_{input} \leq Fr_1 \times 0,2;$$

$$Fr_{input} \leq Fr_1$$

Fa_{input} - axial load generated by driving machine;
 Fr_{input} - radial load generated by driving machine;

Fr_1 and Fa_1 values can be applied simultaneously.

Erforderliche Einsatzbedingungen

$$Fa_{input} \leq Fr_1 \times 0,2;$$

$$Fr_{input} \leq Fr_1$$

Fa_{input} - Axialbelastung welche durch den Antrieb hervorgerufen wird;
 Fr_{input} - Radialbelastung welche durch den Antrieb hervorgerufen werden;

Die Werte von Fr_1 und Fa_1 können gleichzeitig angewendet werden.

1.4 Verifiche

02 2) Verifica carichi radiali e assiali

2.2) Albero uscita

I carichi massimi Fr2 sono calcolati alla distanza "X" indicata in tabella, tali valori sono riportati nelle tabelle delle prestazioni.

	Size	802	804	806	808	810	812	814	816	818	820	822	824
X - [mm]	RX01-TR	500	550	600	650	700	750	800	800	800	800	800	850
	RX02-TR	—						800	800	800	800	—	

Fr₂ [N]	Carico radiale ammissibile su albero uscita indicato a catalogo	<i>Output shaft OHL capacity as per catalogue rating</i>	An Abtriebswelle gemäß Katalogangaben zulässige Radialkraft
X [mm]	Distanza dalla battuta dell'albero	<i>Distance from shaft shoulder</i>	Distanz vom Wellenansatz
R [mm]	Sporgenza dell'albero uscita	<i>Output shaft projection</i>	Überstand der Abtriebswelle

Condizioni applicative necessarie

$$Fa_{input} \leq Fr_1 \times 0,2;$$

$$Fr_{input} \leq Fr_1$$

Fa_{output} - carico assiale generato dalla ventola;
Fr_{output} - carico radiale generato dalla ventola;

Fa₂ - carico assiale ammissibile in uscita;.

I valori di Fr2 ed Fa2 possono essere applicati contemporaneamente.

Necessary conditions for application

$$Fa_{input} \leq Fr_1 \times 0,2;$$

$$Fr_{input} \leq Fr_1$$

Fa_{output} - axial load generated by the fan;
Fr_{output} - radial load generated by the fan;

Fa₂ - Axial load capacity as per catalogue rating.

Fr2 and Fa2 values can be applied simultaneously.

1.4 Überprüfungen

2) Überprüfung der Radial- und Axialkräfte

2.2) Abtriebswelle

Die maximalen Belastungen Fr2 sind mit den in der Tabelle angegebenen Entfernung berechnet, diese Werte sind in den Leistungstabellen dargestellt .

Erforderliche Einsatzbedingungen

$$Fa_{input} \leq Fr_1 \times 0,2;$$

$$Fr_{input} \leq Fr_1$$

Fa_{output} - Axiallasten welche durch das Lüfterrad hervorgerufen werden;
Fr_{output} - Radiallasten welche durch das Lüfterrad hervorgerufen werden;

Fa₂ - An Abtriebswelle gemäß Katalogangaben zulässige Axialkraft;

Die Werte von Fr2 und Fa2 können gleichzeitig angewendet werden.

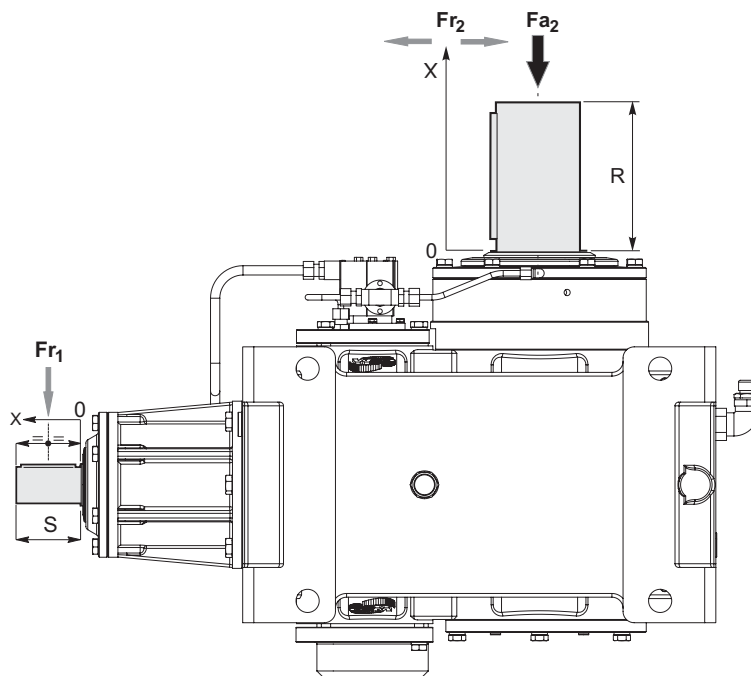

1.4 Verifiche

03 3) Adeguatazza della potenza termica del riduttore:
 Nel caso di solo riduttore in servizio continuo o intermittente gravoso in ambienti a temperatura elevata e/o con difficoltà di scambio termico (es. acciaierie) è necessario verificare che la potenza termica nominale corretta dai fattori sia superiore alla potenza assorbita come evidenziato nella seguente equazione:

1.4 Verification

3) Ensure gear unit thermal power is suitable for the application:
 If a gear unit is to be used in continuous or intermittent duty in environments where high temperatures and/or poor heat exchange are encountered (such as steelworks), check to ensure the thermal power obtained after application of the relevant correction factors is greater than absorbed power, i.e. that the following condition is verified:

1.4 Überprüfungen

3) Angemessene thermische Grenzleistung des Getriebes:
 Wird ein einziges Getriebe im Dauerbetrieb oder harten Schaltbetrieb in einer Umgebung mit hohen Temperaturen und/oder einem schwierigem Wärmeaustausch (z.B. Stahlwerke) eingesetzt, muss geprüft werden, dass die thermische, von den jeweiligen Faktoren korrigierte Nenngrenzleistung über der Aufnahmeleistung liegt, wie es in der folgenden Gleichung dargestellt wird:

$$P_1 \leq P_{tN} \cdot f_a \cdot f_d \cdot f_p \cdot f_f \quad [\text{kW}]$$

Dove:

P_{tN} = potenza termica nominale
 f_a = fattore correttivo dell'altitudine
 f_d = fattore correttivo del tempo di lavoro
 f_p = fattore correttivo della temperatura ambiente
 f_f = fattore correttivo di aerazione con ventola

Where:

P_{ta} = thermal power rating
 f_a = altitude factor
 f_d = operation time factor
 f_p = ambient temperature factor
 f_f = fan cooling factor

Hier ist:

P_{ta} = termische Nenngrenzleistung
 f_a = Höhenkorrekturwert
 f_d = Korrekturfaktor der Arbeitszeit
 f_p = Korrekturfaktor der Umgebungstemperatur
 f_f = Korrekturfaktor der Belüftung durch Lüfter

P_{tN}	Potenza termica nominale Thermal power rating Termische Nenngrenzleistung										
----------------------------	---	--	--	--	--	--	--	--	--	--	--

	802	804	806	808	810	812	814	816	818	820	822	824
RX01-TR	30	39	51	66	82	104	127	158	203	252	304	368
RX02-TR	—					102	127	165	205	—		

f_a	Fattore correttivo dell'altitudine Altitude factor Korrekturwert der Höhe					
-------------------------	---	--	--	--	--	--

m	0	750	1500	2250	3000
f_a	1	0.95	0.90	0.85	0.81

f_d	Fattore correttivo del tempo di lavoro Operation time factor Korrekturwert der Betriebszeit				
-------------------------	---	--	--	--	--

S3%	100	80	60	40	20
f_d	1	1.05	1.15	1.35	1.8

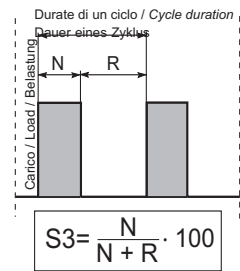

f_p	Fattore correttivo della temperatura ambiente Ambient temperature factor Korrekturfaktor der Umgebungstemperatur					
-------------------------	--	--	--	--	--	--

Temperatura ambiente Ambient temperature Umgebungstemperatur	50 °C	40 °C	30 °C	20 °C	10 °C	0 °C
f_p	0.63	0.75	0.87	1	1.12	1.25

1.4 Verifiche

1.4 Verification

1.4 Überprüfungen

ff

Fattore di aerazione
Aeration factor
Belüftungsfaktor

Il fattore correttivo ff della potenza termica che tiene conto dell'effetto refrigerante della ventola assume in accordo con le norme AGMA 6010.E88 i valori riportati nella tabella. L'impiego è limitato alle velocità maggiori o uguali a 700 min⁻¹.

Cooling fan factors ff reported in table 8 are in accordance with AGMA 6010.E88 and can be used directly to adjust thermal power to reflect the use of a cooling fan. These factors must only be used for speeds equal to 700 rpm and higher.

In Übereinstimmung mit den Normen AGMA 6010.E88 nimmt der Korrekturwert ff der thermischen Grenzleistung, der den Kühleffekt des Lüfters berücksichtigt, die in der Tabelle angegebenen Werte an. Der Einsatz beschränkt sich auf die Drehzahlen die 700 min⁻¹ betragen oder darüber liegen.

ff	Tipo Type Typ	Tipo ventola Fan type Lüfertyp	Note Notes Hinweise
1.7	RXO	VE	—

04

4) Condizioni di impiego:

4.1 - ta > 0 °C: vedere i punti 1.8;
4.2 - ta < -10 °C: contattare il nostro servizio tecnico-commerciale.

4) Using conditions:

4.1 - ta > 0 °C: look at points 1.8;
4.2 - ta < -10 °C: contact our technical sales dept.

4) Anwendungsbedingungen:

4.1 - ta > 0 °C: siehe Punkt 1.8;
4.2 - ta < -10 °C: bitte kontaktieren sie unsere technische Verkaufsabteilung.

1.4 Verifiche

1.4 Verification

1.4 Überprüfungen

05 5) Coppie antiretro

5) Back-stop device torque

5)Rücklauf-Drehmomente

E' necessario che sia soddisfatta la seguente relazione:

The following ratio must be met:

Folgendes Verhältnis muss gegeben sein

$$T_{1a} > \left(\frac{T_{2r} * 100}{RD * ir} \right)$$

T _{1a} - [Nm]	T _{1a}				
	i < 13	i < 13,5	13,1 < i < 19,6	13,6 < i < 19,7	i > 19,8
802	462	—	307	—	219
804	462	—	307	—	219
806	517	—	344	—	245
808	—	937	—	601	429
810	—	1639	—	1090	777
812	—	1639	—	1090	777
814	—	2148	—	1427	1018
816	—	3395	—	2256	1609
818	—	4183	—	2870	1982
820	—	4107	—	2780	1982

RXO2 - RXV2	
T _{1a}	
i < I _r max	
814	1639
816	1639
818	2148
820	3395

T_{2r} = Coppia uscita moto retrogrado;
RD = Valore del rendimento dinamico riduttore;
ir = rapporto riduzione

T_{2r} = output torque retrograde motion;
RD = Value of gearbox dynamic performance;
ir = reduction ratio

T_{2r} = Rückläufiges Abtriebsdrehmoment
RD = Die Werte der dynamischer Getriebewirkungsgrad
ir = Untersetzungsverhältnis

T_{1a} = Coppia limite in ingresso del dispositivo antiretro - [Nm].

T_{1a} = income limit torque for back-stop device - [Nm].

T_{1a} = Grenzantriebsmoment der Rücklauf Sperre - [Nm].

06 6) Application Data Sheet

06)Application Data Sheet

06)Application Data Sheet

Qualora le precedenti verifiche non risultino esaustive è necessario rivolgersi al nostro servizio tecnico commerciale compilando il seguente schema:

If the previous tests are not exhaustive please contact our sales department by filling in the following form.

Wenn die oben genannten Tests nicht umfangreich genug sein sollten, ist es notwendig, sich an unsere technische Verkaufsabteilung zu wenden und folgendes Formular auszufüllen:



6 - Application Data Sheet

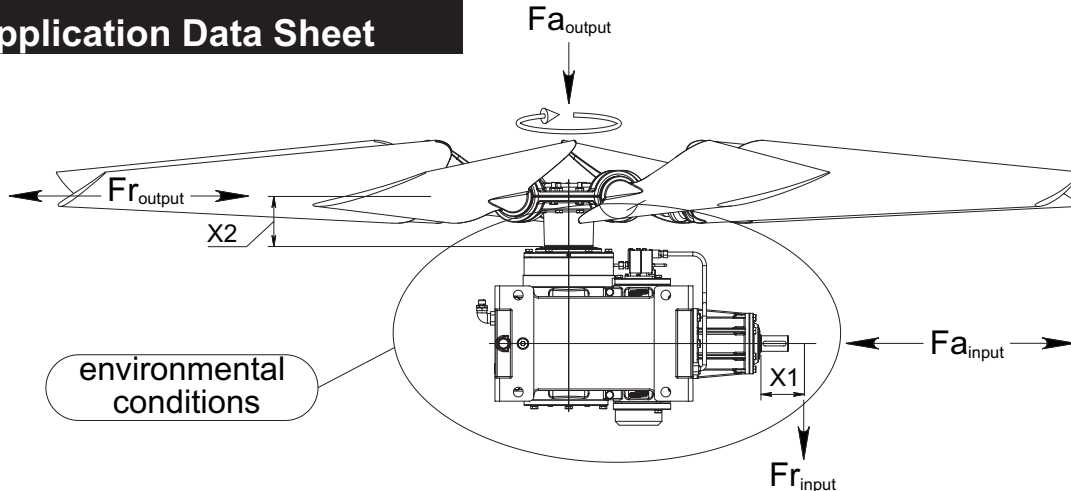

Symbol	Measurement	Descrizione	Description	Beschreibung	Fields to fill-in	
A - PARAMETRI TECNICI CALCOLO DI BASE / CALCULATIONS TECHNICAL RATINGS/ TECHNISCHE PARAMETER						
Typ_UM	-	Tipo Unità Motrice	Type Unit Motor	Typ Antrieb-Motor	<input type="checkbox"/> AC	<input type="checkbox"/> Inverter
P1	kW	Potenza motore	Motor power	Leistung Motor		_____ kW
P1a	kW	Potenza motore assorbita	Real Input Motor	Motorleistung Aufnahmen		_____ kW
n _{1n}	rpm	Velocità albero entrata	Input speed	Antriebsdrehzahl		_____ rpm
n _{2n}	rpm	Velocità albero in uscita	Output speed	Abtriebsdrehzahl		_____ rpm
ir (n _{1n} /n _{2n})		Rapporto di trasmissione	Ratio	Übersetzungsverhältnis		_____
n _{1max}	min ⁻¹	Velocità massima albero entrata	Input shaft max speed	Minimale Drehzahl der Antriebswelle		_____ rpm
n _{1min}	min ⁻¹	Velocità minima albero entrata	Input shaft min speed	Minimale Drehzahl der Antriebswelle		_____ rpm
SO	-	Senso rotazione Albero uscita	Sense of Rotation	Drehrichtung	<input type="checkbox"/> Clock-Wise (Standard)	<input type="checkbox"/> Anticlockwise
B - Carichi Esterni Albero Entrata / Input shaft - external loads / Antriebswelle - Externe Belastung						
Fr _{input}	N	Carico Radiale Nominale Applicazione	Application nominal radial load -	Radial-Nennlast		_____ N
X1	mm	Distanza Carico Radiale Nominale Applicazione	Application nominal radial load distans	Abstand der Radial-Nennlast		_____ mm
Fa _{input}	N	Carico Assiale Nominale Applicazione	Application nominal axial load	Effektive Axialbelastung		_____ N
C - Carichi Esterni Albero Uscita / Output shaft - external loads / Abtriebelle - Externe Belastung						
Fr _{output}	N	Carico Radiale Nominale Applicazione	Application nominal radial load -	Radial-Nennlast		_____ N
X2	mm	Distanza Carico Radiale Nominale Applicazione	Application nominal radial load distans	Abstand der Radial-Nennlast		_____ mm
Fa _{output}	N	Carico Assiale Nominale Applicazione	Application nominal axial load	Effektive Axialbelastung		_____ N
D - Condizioni ambientali / Enviromental Conditions / Umgebung						
t _{astart}	°C	Temperatura ambiente durante avviamento	Start-up ambient temperature	Umgebungstemperatur beim Anfahren		_____ °C
t _{an}	°C	Temperatura ambiente Funzionamento	Working ambient Temperature	Umgebungstemperatur in Funktion		_____ °C
Z _{typ}	-	Tipo ambiente - Esempio Gas corrosivi ecc...	Type of environment - for example corrosive gas, etc	Umweltbeschaffenheit-Beispiel: Korrosive Gase etc.		_____
E - Antiretro / Backstop / Rücklaufsperr						
AR _B	-	Antiretro	Backstop	Rücklaufsperr	<input type="checkbox"/> Yes	<input type="checkbox"/> No
T _{2r}	Nm	Coppia limite in ingresso del dispositivo antiretro	Income limit torque for back-stop device	Grenzantriebsmoment der Rücklaufsperr		_____ Nm
F - Altre Informazioni / More Informations / Weitere Informationen						
L _{SPL}	SPL-dB(A)	Livelli di pressione sonora	Mean sound pressure levels	Schalldruckpegel		_____ dB(A)
TYPE _{OPT1}	-	Tipo verniciatura	Type Painting	Typ-Lackierung	<input type="checkbox"/> TYP3 (std) <input type="checkbox"/> TYP4	<input type="checkbox"/> Other Specification
Typ _{material}	-	Caratteristiche materiali non idonei all'applicazione Esempio - Alluminio...	Material specifications not suitable for the application For Example: Aluminium...	Für die Anwendung ungeeignete Materialien Beispiel: Aluminium		_____

1.5 Stato di fornitura

1.5.1 Protezione alla corrosione e protezione superficiale - RX 800

General information

GSM propone diverse soluzioni protettive opzionali per motori e riduttori che lavorano in speciali condizioni ambientali.
Le misure protettive sono costituite da:
- Protezione corrosiva e protezione superficiale per motori e riduttori;
- Colore Standard RAL 5010

1.5.1.1 - Protezione Corrosiva

La protezione corrosiva è ottenuta con le seguenti specifiche come standard:

- Le targhette sono realizzate in acciaio inox;
- Applicazione di un prodotto anticorrosivo temporaneo per proteggere le superfici di accoppiamento delle flange e gli alberi uscita.

Nel caso di specifiche richieste è possibile applicare tutte le viti di fissaggio in acciaio inox.

1.5.1.2 - Verniciatura e protezione Superficiale

I riduttori preventivamente sabbiati vengono verniciati con vernice ad alto solido, internamente antioil ed esternamente con fondo epossidico anticorrosivo di colore grigio o rosso ricoperto da finitura poliuretana bicomponente di colore Blu RAL 5010 (TYP3).

Nel caso si debbano prevedere impieghi in ambienti industriali più aggressivi o corrosivi o estremi o più genericamente di tipo marino, occorre adottare prodotti adeguati apposti con opportuno ciclo di verniciatura. In questi casi si suggerisce di concordare il ciclo in fase di ordine.

La GSM comunque propone già cicli di verniciatura speciali selezionati per ambienti di questo tipo (TYP4).

1.5 Scope of the supply

1.5.1 - Corrosion and surface protection - RX 800

General information

GSM offers different protective solutions for motors and gearboxes which work in special weather condition
The protective measures are:
- Corrosion and surface protection for motors and gearboxes;
- Standard color RAL 5010

1.5.1.1 - Corrosion protection

The corrosion protection is the result of the following standard procedures:

- The name plates are made of inox steel;
- An anticorrosive temporary product is applied on the mechanized surfaces of flanges and output shafts

In case of special requests it is possible to use inox steel screws

1.5.1.2 - Painting and surface protection

Gearboxes, after being sand blasted, are painted with a specific paint, which has a double function. On the internal side it works as an anti-oil, while on the external side it works as a grey or red anticorrosive epoxy primer covered by a blue RAL 5010 (TYP 3) bi-component polyurethane finishing paint.

In case of use in aggressive or corrosive industrial or sea environments, it is necessary to use special products with the required painting cycle. We suggest you to specify these particular terms with our company.

GSM offers already special painting cycles, which have been created for these kind of environments (TYP 4).

1.5 Lieferzustand

1.5.1 - Korrosionsschutz und Oberflächenschutz - RX 800

Allgemeine Information

GSM bietet optional verschiedene Schutzmöglichkeiten für Motoren und Getriebe an, die in besonderen Umweltbedingungen arbeiten
Die Schutzmaßnahmen bestehen aus:
-Korrosionsschutz und Oberflächenschutz für Motoren und Getriebe;
Standardfarbe RAL 5010

1.5.1.1 - Korrosionsschutz

Der Korrosionsschutz ist bei den folgenden Spezifikationen standardmäßig:

- Die Typenschilder sind aus Edelstahl;
- Anwendung eines temporären Antikorrosionsproduktes als Oberflächenschutz für die Flansch und Abtriebswellenverbindungen

Im Falle spezifischer Anfragen können alle Befestigungsschrauben aus Edelstahl verwendet werden.

1.5.1.2 - Lackierung und Oberflächenschutz

Die vorbeugend sandgestrahlten Getriebe werden mit Farbe mit hohem Feststoffgehalt lackiert, innen gegen das Öl und außen gegen Korrosion mit Epoxid in grauer oder roter Farbe. Und werden abschließend mit Bikomponentenpolyurethan in der Farbe blau RAL 5010 (TYP 3) überzogen..

Sollte der Einsatz in industriellen Bereichen erfolgen, die aggressiver oder korrosiver oder extremer oder allgemein den marinen Bereich betreffen, müssen hierfür geeignete Produkte mit den entsprechenden Lackierzyklen verwendet werden. In diesen Fällen wird vorgeschlagen zuzustimmen.

Die GSM schlägt hier jedoch bereits speziell ausgewählte Lackierzyklen für Bereiche dieser Art vor (TYP4).

Protezione superficiale Surface protection	Numero di strati Permutation of layers	Spessore Coat thickness	Adatto per Suitable for
TYP 3 Industriale Industrial	1x Primer 2x Two-pack Intermediate 1x Two-pack top coat	Circa/Approx. 240 micron A Secco/Dry	1 - Impatto ambientale ALTO - Applicazione industriale High environmental impact - Industrial Application 2 - Umidità relativa massima 100 % Relative humidity max. 100 % 3-Temperatura superficiale massima 120 °C Surface temperature up to max. 120 °C 4 - Categoria di corrosività "C5I-M" (DIN EN ISO 12,944-2) Corrosivity category "C5I-M" (DIN EN ISO 12,944-2)
TYP 4 Marino Marine	1x Zinc Primer 2x Two-pack Intermediate 2x Two-pack top coat	Circa/Approx. 320 micron A Secco/Dry	1 - Alto impatto ambientale - Applicazione ambiente marino High environmental impact - Marine Application 2 - Umidità relativa massima 100 % Relative humidity max. 100 % 3-Temperatura superficiale massima 120 °C Surface temperature up to max. 120 °C 4 - Categoria di corrosività "C5M-M" (DIN EN ISO 12,944-2) Corrosivitycategory "C5M-M" (DIN EN ISO 12,944-2)

A richiesta è possibile fornire ciclo di verniciatura ,schede tecniche dei prodotti utilizzati e report di prova
If requested, we can supply you with painting procedures, data sheets of the products which have been used and testing reports
Auf Anfrage ist es möglich den Lackierzyklus, technische Leistungsblätter der benutzten Produkte und Testberichte zur Verfügung zu stellen

1.5 Stato di fornitura

1.5 Scope of the supply

1.5 Lieferzustand



OPT2 - Opzioni - Verniciatura <i>Options - Painting and surface protection</i> Optionen - Lackierung und Oberflächenschutz					
Serie <i>Series</i> Baureihe	Verniciatura Interna <i>Inner painting</i> Innenlackierung	Verniciatura Esterna <i>Outer painting</i> Außenlackierung		Piani lavorati <i>Machined surfaces</i> Bearbeitete Flächen	Alberi <i>Shafts</i> Wellen
		Tipo e Caratteristiche vernice <i>Paint type and features</i> Lacktyp und -eigenschaften	Verniciabile <i>Can be painted</i> Kann lackiert werden		
TYP 3					
RXO.	fondo epossidico anticorrosivo di colore grigio o rosso <i>Grey or red anticorrosive epoxy primer</i> Epoxidkorrosionsschutz in grauer oder roter Farbe	ricoperto da finitura poliuretanica bicomponente di colore Blu RAL 5010 (TYP3) <i>Covered by a blue RAL 5010 (TYP 3) bi-component polyurethane finishing paint</i> überzogen mit Bikomponentenpolyurethan in der Farbe blau RAL 5010 (TYP 3)	Sì	Protetti con prodotto antiruggine. <i>Protected by oxide protectant</i> Mit Rostschutzpaste geschützt.	Protetti con prodotto antiruggine <i>Protected by oxide protectant.</i> Mit Rostschutzpaste geschützt.

ATTENZIONE
In caso di verniciatura o asportazione del prodotto antiruggine si chiede di porre attenzione alla preventiva protezione:
- Delle superfici lavorate, al fine di evitare che una eventuale verniciatura delle stesse pregiudichi il successivo accoppiamento.
-Delle tenute e più in generale di ogni parte plastica e di gomma, al fine di non variane le caratteristiche chimico fisiche pregiudicandone così l'efficienza.
-Alla targa di identificazione per evitare la perdita di tracciabilità.
-Al tappo sfiato ed al tappo di livello olio, al fine di evitarne l'occlusione.

ATTENTION
If the product must be painted or cleaning off any antirust paint, protect the machined surfaces and oil seals/gaskets in order to prevent any damage.
It is also necessary to protect the identification plate, the oil level plug (if fitted) and the hole in the breather plug (if fitted) against obstruction.

ACHTUNG
Sollten die Produkte lackiert werden oder Abbau des Rostschutzmittels, muss darauf geachtet werden, dass die bearbeiteten und Dichtflächen dabei geschützt werden, so dass verhindert werden kann, dass die Lackierung die chemisch-physischen Eigenschaften verändert und die Wirkung der Ölabdichtungen eingeschränkt. In der gleichen Weise und aus gleichem Grund müssen das Typenschild und die Öleinfüllschraube sowie die Bohrung der Entlüftungsschraube (wo vorhanden) geschützt werden.

1.5.3 MATERIALI COSTRUTTIVI

1.5.3 MATERIAL

1.5.3 KOSTRUKTIONSMATERIAL

1.5.3.1 Casse - Flange - Coperchi

1.5.3.1 Housings - Flanges - Covers

1.5.3.1 Gehäuse - Flanschen – Deckel

Serie <i>Series</i> Baureihe	Per ulteriori informazioni vedere 1.6.5 <i>For more details, please read 1.6.5</i> Sie können Weitere Informationen siehe 1.6.5
RXO.	

1.5.3.2 Materiale degli anelli di tenuta

1.5.3.2 Materials of Seals

1.15.2.2 Dichtungsstoffe

Serie <i>Series</i> Baureihe	OPT Opzioni - Materiale degli anelli di tenuta <i>Options - Materials of Seals</i> Optionen - Dichtungsstoffe	
	(Tenute STANDARD <i>Oil Seals Standard</i> Ölabdichtungen Standard) Opzioni - Disponibile <i>Options Available</i> Optionen - verfügbar
RXO.	Per ulteriori informazioni vedere SEZIONE U <i>For more details, please read SECTION U</i> Sie können Weitere Informationen siehe ABSCHNITT U	

1.5.4 Lubrificazione

1.5.4 Lubrication

1.5.4 Schmierung

RX	OPT1 - Opzioni - Stato fornitura olio <i>Options - Scope of the supply - Options - OIL</i> Optionen - Lieferzustand - Optionen - Öl	
		Sigla ordine <i>Designation order</i> Bezeichnung Bestellung
	all sizes	OUTOIL

1.5 Stato di fornitura

1.5 Scope of the supply

1.5 Lieferzustand

1.5.4 Lubrificazione

1.5.4 Lubrication

1.5.4 Schmierung

ATTENZIONE:







Lo stato di fornitura è messo in evidenza con una targhetta adesiva posta sul riduttore.
Verificare la corrispondenza tra stato di fornitura e targhetta adesiva.

CAUTION:

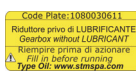
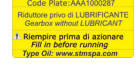
*Gearbox state of supply is indicated on a nameplate applied on gearbox.
Ensure that nameplate data and state of supply correspond.*

ACHTUNG:

Der entsprechende Lieferzustand wird auf einem Aufkleber am Getriebe angegeben. Überprüfen Sie die Übereinstimmung zwischen effektivem Lieferzustand und Aufkleber.

OPT1 - Opzioni - Stato fornitura olio- Options - Scope of the supply - Options - OIL Optionen - Lieferzustand - Optionen - Öl									
Stato fornitura <i>Scope of the supply</i> Lieferzustand	Riduttore - Lubrificazione <i>Gearbox - Lubrication</i> Getriebe - Schmierung	Tipo Type Typ	NOTE Note Hinweis	Targhetta <i>Nameplate</i> Aufkleber					
<p>OUTOIL</p> <p>Riduttore Privo di Lubrificante <i>Gearbox with no lubricant</i> Getriebe ohne Schmiermittel</p>	<p>Si consiglia l'uso di oli a base sintetica. Vedere a tale proposito le indicazioni riportate paragrafo 1.8.</p> <p><i>The use of synthetic oil is recommended. see details in paragraph 1.8.</i></p> <p>Der Einsatz von synthetischem Öl wird empfohlen. Siehe diesbezüglich die Hinweise im Abschnitt 1.8.</p>		<p>Se richiedi completi di lubrificante, verranno forniti con olio standard - "INOIL_STD"</p> <p><i>If customer requests supply of gearbox with lubricant, we shall supply - "INOIL_STD"</i></p> <p>Falls diese Getriebe mit Schmiermittelfüllung angefordert werden - "INOIL_STD"</p>	 					
<p>INOIL_STD</p> <p>Riduttore Completo di Lubrificante Standard STM <i>Gearbox with lubricant STM standard</i> Getriebe mit Standard Schmiermittel STM</p>	<p>RXO1 TR A richiesta / <i>on request</i> / Auf anfrage ASOIL</p>		On request						
<p>INOIL_Food</p> <p>Riduttore Completo di Lubrificante "ALIMENTARE" <i>Gearbox with lubricant "FOOD-TYPE"</i> Getriebe mit Schmiermittel "LEBENSMITTEL"</p>	<p>RXO1 TR A richiesta / <i>on request</i> / Auf anfrage ASOIL</p>		On request						
<p>ASOIL</p> <p>Riduttore Completo di Lubrificante Speciale - a richiesta <i>Gearbox with Special lubricant - On request</i> Getriebe mit Sondern-Schmiermittel - Auf Anfrage</p>	<p>A richiesta <i>On request</i> Auf Anfrage</p>	<table border="1" style="width: 100%; border-collapse: collapse;"> <tr><td style="padding: 2px;">OilGear_TYPE CLP PG Synthetic PG</td></tr> <tr><td style="padding: 2px;">OilGear_TYPE CLP HC Synthetic PAO</td></tr> <tr><td style="padding: 2px;">OilGear_TYPE CLP Mineral</td></tr> <tr><td style="padding: 2px;">OilGear_TYPE CLP HCE Synthetic HCE NSF H1</td></tr> <tr><td style="padding: 2px;">Grease</td></tr> </table>	OilGear_TYPE CLP PG Synthetic PG	OilGear_TYPE CLP HC Synthetic PAO	OilGear_TYPE CLP Mineral	OilGear_TYPE CLP HCE Synthetic HCE NSF H1	Grease	—	    
OilGear_TYPE CLP PG Synthetic PG									
OilGear_TYPE CLP HC Synthetic PAO									
OilGear_TYPE CLP Mineral									
OilGear_TYPE CLP HCE Synthetic HCE NSF H1									
Grease									

Nota campo- ASOIL

Nella targhetta sono riportate le seguenti informazioni:

- Code_Plate;
- Sigla lubrificante;
- ISO VG;
- Type DIN;
- NSF;
- Altre prescrizioni.

Note range-ASOIL

The type plate contains the following information:

- Code_Plate
- Lubricant type
- ISO VG
- Type DIN
- NSF
- other details

Hinweis Bereich-ASOIL

Auf dem Typenschild finden Sie folgende Informationen:

- Code_Plate
- Schmiermitteltyp
- ISO VG
- Type DIN
- NSF
- andere Hinweise

1.5 Stato di fornitura

1.5.4.2 - Lubricazione cuscinetti

1.5 Scope of the supply

1.5.4.2 - Bearing lubrication

1.5 Lieferzustand

1.5.4.2 - Schmierung der Abtriebslagerung

Pos. Mont. M5 - M6

Mntg. Pos. M5 - M6

Einbaulage M5 - M6

	Grandezza / Size / Baugröße											
	802	804	806	808	810	812	814	816	818	820	822	824
$n_1 \geq n_{1min}$	G (grease)			LFP3								
$n_1 < n_{1min}$	G (grease)											
	G (grease)											

I valori di n_1 min sono riportati nel paragrafo Verifiche, punto 1).

n_1 min values are listed at paragraph Verification, point 1).

Die Werte von n_1 min werden im Paragraph "Kontrollen", Punkt 1, angegeben.

1.5.4.2.1 - G - (grease)

Pertanto è stato predisposto un ingrassatore per provvedere all'opportuno ringrassaggio.

Pertanto è stato predisposto un ingrassatore per provvedere all'opportuno ringrassaggio.

Le Caratteristiche tecniche generali del grasso utilizzato sono:

- Inspessente: base di Litio Complesso;
- NGLI: 2;
- Olio: HCE - con aditivazione EP di viscosità minima ISO VG 220;
- Additivi: l'olio presente nel grasso deve

1.5.4.2.1 - G - (grease)

To this end it is provided with a greaser.

To this end it is provided with a greaser.

Following are the general technical features of the lubrication grease:

- Thickener: Complex Lithium-based;
- NGLI: 2;
- Oil: HCE with EP additives with minimum viscosity as per ISO VG 220;
- Additives: the oil in the grease must fea-

1.5.4.2.1 - G - (grease)

Daher wurde ein angemessener Schmiernippel für das Nachschmieren vorgesehen.

Daher wurde ein angemessener Schmiernippel für das Nachschmieren vorgesehen.

Allgemeine technische Eigenschaften des verwendeten Fetts:

- Verdickungsmittel: auf Lithiumkomplex;
- NGLI: 2;
- Öl: HCE mit Zusatz von EP mit Mindestviskosität gemäß ISO VG 220;
- Additive: das im Fett enthaltene Öl muss

1.5.4.2.2 - LFP...: Pompa

(vedi sezione U accessori e opzioni).

1.5.4.2.2 - LFP...: pump

(see Section U Accessories and Options).

1.5.4.2.2 - LFP...: Pumpe

(siehe Abschnitt U „Zubehör und Optionen“).



1.5.5 Antiretro

Qualora sia presente un dispositivo antiretro

una freccia ne evidenzia il senso di rotazione consentito.

1.5.5 Back-stop device

In the event a back-stop device is provided, an arrow indicates its permitted direction of rotation.

1.5.5 Rücklaufsperr

Sollte eine Rücklaufsperr vorhanden sein, wird die zulässige Drehrichtung durch einen Pfeil angegeben.

1.6 Normative applicate

1.6 Standards applied

1.6 Angewendete Normen

1.6.1 Specifiche prodotti non "ATEX"

1.6.1 Specifications of non - "ATEX" products

1.6.1 Spezifikationen für produkte, die nicht der "ATEX"-norm entsprechen

I riduttori della GSM SpA sono organi meccanici destinati all'uso industriale e all'incorporazione in apparecchiature meccaniche più complesse. Dunque non vanno considerati macchine indipendente per una predeterminata applicazione ai sensi 2006/42/CE, né tantomeno dispositivi di sicurezza.

GSM SpA gearboxes are mechanical devices for industrial use and incorporation in more complex machines. Consequently, they should not be considered neither self-standing machines for a pre-determined application according to 2006/42/CE nor safety devices.

Bei den Getrieben der GSM SpA handelt es sich um Mechanikorgane, die für den industriellen Einsatz und einen Einbau in komplexere Einrichtungen bestimmt sind. Sie werden deshalb weder unter dem Aspekt unabhängiger, für eine bestimmte Anwendung vorgesehener Maschinen im Sinne der 2006/42/CE, noch als Sicherheitsvorrichtungen berücksichtigt.

1.6 Normative applicate

1.6.2 Specifiche prodotti "ATEX"

Campo applicabilità

La direttiva ATEX (2014/34/UE) si applica a prodotti elettrici e non elettrici destinati a essere introdotti e svolgere la loro funzione in atmosfera potenzialmente esplosiva. Le atmosfere potenzialmente esplosive vengono suddivise in gruppi e zone a seconda della probabilità di formazione. I prodotti GSM sono Conformi alla seguente classificazione:

- 1- Gruppo: II
- 2- Categoria: **Gas 2G polveri 2D**
- 3- Zona: **Gas 1 ; 2 – Polveri 21;22**

1.6 Standards applied

1.6.2 Specifications of "ATEX" products

Application field

ATEX set of provisions (2014/34/UE) is referred to electric and non-electric products which are used and run in a potentially explosive environment. The potentially explosive environments are divided into different groups and zones according to the probability of their formation. GSM products are in conformity with following classification:

- 1- Group : II
- 2- Type : **Gas 2G dust 2D**
- 3-Zone : **Gas 1;2 – Dust 21;22**

1.6 Angewendete Normen

1.6.2 Spezifikationen für "ATEX"-produkte

Anwendungsbereich

Die ATEX-Richtlinie (2014/34/UE) wird bei elektrischen und nicht elektrischen Produkten angewendet, die dazu bestimmt sind, in potentiell explosionsfähigen Atmosphären eingesetzt und betrieben zu werden. Die potentiell explosionsfähigen Atmosphären werden in Abhängigkeit der Wahrscheinlichkeit in Gruppen und Zonen unterteilt. Die GSM-Produkte entsprechen der folgenden Klassifizierung:

- 1- Gruppe: II
- 2- Kategorie: **Gas 2G Staub 2D**
- 3- Zone: **Gas 1;2 - Staub 21;22**

Massime temperature di superficiali / Max surface temperature allowed / Maximale Oberflächentemperaturen					
Classe di temperatura / Temperature class / Temperaturklasse	T1	T2	T3	T4	T5(1)
Massima temp.di superficie / Max surface temperature / Max. Oberflächentemperaturen (°C)	450	300	200	135	100(1)
Classi di temperatura ATEX dei prodotti GSM / ATEX temperature class of GSM products / ATEX Temperaturklassen der GSM-Produkte					

I prodotti GSM sono marcati classe di temperatura **T4** per IIG (atmosfera gassosa) e **135° C** per IID (atmosfera polverosa).

Nota 4:

Nel caso di Classe di temperatura T5 occorre verificare la potenza limite termico declassata;

In tutti gli altri casi vale la potenza riportata a catalogo prevista per i singoli rapporti con fattore di servizio complessivo dell'applicazione pari a 1 e le considerazioni sul limite termico.

I prodotti del gruppo IID (atmosfera polverosa) vengono definiti dalla massima temperatura di superficie effettiva.

La massima temperatura di superficie è determinata in normali condizioni di installazione e ambientali (-20°C e +40°C) e senza depositi di polvere sugli apparecchi. Qualunque scostamento da queste condizioni di riferimento può influenzare notevolmente lo smaltimento del calore e quindi la temperatura.

1.6.3. COME SI APPLICA

Al momento di una richiesta di offerta per prodotto conforme a normativa ATEX 2014/34/UE occorre compilare la **scheda acquisizione dati** (www.stmspa.com). Effettuare le verifiche come prima descritto. I riduttori certificati verranno consegnati con:
 -una seconda targhetta contenente i dati ATEX;
 -ove previsto un tappo sfiato, tappo sfiato con molla interna;
 -se rispondente alla classe di temperatura T4 e T5 verrà allegato un indicatore di temperatura (132 °C nel caso di T4 e 99°C rispettivamente per la T5)
 -Indicatore di temperatura : termometro a singolo rilevamento, una volta raggiunta la temperatura indicata si annerisce segnalando il raggiungimento di tale limite.

GSM products are branded temperature class **T4** for IIG (gas environment) and **135°C** for IID (dust environment).

Note 4:

In case of T5 Class of temperature the extreme down-graded thermic power should be checked.

In all the other instances, the power indicated on the catalogue for the single ratios with overall application service factor equal to 1 and the considerations on temperature limits apply.

The products of the family IID (dust environment) are defined by the max effective surface temperature.

Max surface temperature is determined in standard installation and environmental conditions (-20°C and +40°C) and in absence of dust on product surface. Any other condition will modify the heat dissipation and consequently the temperature.

1.6.3. HOW IS IT APPLIED

In case of request of offer relating to any product in conformity with the provisions ATEX/2014/34/UE, the **specifications paper** should be filled in (www.stmspa.com). Perform the inspections as described above. Certified reducers will be delivered with:
 - a second nameplate containing ATEX data;
 - a breather valve with internal spring, where a breather is needed;
 - if in accordance with classes of temperature T4 and T5, a temperature gauge will be included (132 °C in case of T4 and 99 °C in case of T5).
 - Temperature gauge: single-reading thermometer, it blackens once temperature is reached, pointing out the achievement of that limit.

Die GSM-Produkte sind mit der Temperaturklasse **T4** für IIG (Atmosphäre mit gasförmiger Belastung) und 135° C für IID (Atmosphäre mit staubförmiger Belastung) gekennzeichnet.

Hinweis 4:

Bei der Temperaturklasse T5 muss die zurückgestufte thermische Grenzleistung überprüft werden. In den anderen Fällen gilt die im Katalog für die einzelnen Übersetzungsverhältnisse angegebene Leistung mit Betriebsfaktor einschließlich Applikation entsprechend 1 und die Berücksichtigungen im Hinblick auf die thermische Grenzleistung.

Die der Gruppe IID (Atmosphäre mit staubförmiger Belastung) angehörigen Produkte werden ihrer effektiven maximalen Oberflächentemperatur gemäß definiert.

Die maximale Oberflächentemperatur wird in normalen Einbau- und Umgebungsbedingungen (-20°C und +40°C) und ohne auf den Vorrichtungen vorhandenen Staubablagerungen bestimmt. Jegliche Abweichung von diesen Bezugsbedingungen kann sich erheblich auf die Wärmeableitung bzw. auf die

1.6.2. ANWENDUNGSWEISE

Bei einer Angebotsanfrage für der Richtlinie ATEX 2014/34/UE entsprechende Produkte muss das Datenerfassungsformular (www.stmspa.com) ausgefüllt werden. Dazu die zuvor beschriebenen Kontrollen vornehmen. Die zertifizierten Getriebe werden wie folgt ausgestattet geliefert:
 -mit einem zweiten Typenschild mit ATEX- Daten;
 -wo vorgesehen, mit einem Entlüftungs- verschluss, Entlüftungsverschluss mit interner Feder;
 -falls der Temperaturklasse T4 und T5 entsprechend, wird eine Temperaturanzeige vorgesehen (132 °C bei T4 und 99°C bei T5)
 -Temperaturanzeige: einzelnes Erfassungsthermometer - bei Erreichen der angegebenen Temperatur wechselt die Farbe zur Anzeige der erreichten Temperatur in Schwarz.

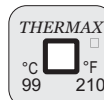
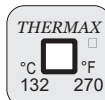

1.6 Normative applicate

1.6.4 UE Directive - marcatura CE-ISO9001

Direttiva Bassa Tensione 2014/35/UE

I motoriduttori, motorivii angolari, motorivariatori e i motori elettrici GSM sono conformi alle prescrizioni della direttiva Bassa Tensione .

2014/30/UE Compatibilità elettromagnetica

I motoriduttori, motoriviiangolari, motorivariatori e i motori elettrici GSM sono conformi alle specifiche della direttiva di Compatibilità Elettromagnetica.

Direttiva Macchine 2006/42/CE

I motoriduttori, motoriviiangolari, motorivariatori e i motori elettrici GSM non sono macchine ma organi da installare o assemblare nelle macchine.

Marchio CE, dichiarazione del fabbricante e dichiarazione di conformità.

I motoriduttori, motorivariatori e i motori elettrici hanno il marchio CE.

Questo marchio indica la loro conformità alla direttiva Bassa Tensione e alla direttiva Compatibilità Elettromagnetica.

Su richiesta, GSM può fornire la dichiarazione di conformità dei prodotti e la dichiarazione del fabbricante secondo la direttiva macchine.

ISO 9001

I prodotti GSM sono realizzati all'interno di un sistema di qualità conforme allo standard ISO 9001. A tal fine su richiesta è possibile rilasciare copia del certificato.

1.6.5 Normative riferimento Progettazione e Fabbricazione

Ingranaggi

Gli ingranaggi cilindrici a dentatura elicoidale, sono rettificati sul profilo ad evolvente dopo cementazione, tempra e rinvenimento finale.

Gli ingranaggi conici a dentatura gleason sono rodati, (o rettificati a seconda della grandezza del riduttore), dopo cementazione tempra e rinvenimento finale.

Cuscinetti

Tutti i cuscinetti sono del tipo a rulli conici o a rulli orientabili, di elevata qualità e dimensionati per garantire una lunga durata se lubrificati con il tipo di lubrificante previsto a catalogo.

Carcassa

La carcassa è ottenuta per fusione in GJL 250 UNI EN 1561 o in ghisa a grafite sferoidale UNI EN 1563 2004 fino alla grandezza 824-826.

I particolari accorgimenti adottati nel disegno della struttura permettono di ottenere un' elevata rigidezza.

1.6 Standards applied

1.6.4 UE Directives-CE mark-ISO 9001

Directive 2014/35/UE Low VoltageGSM

geared motors, right angle drives with motor, motorvariators and electric motors meet the specification of the low voltage directive.

2014/30/UE Electromagnetic Compatibility

GSM geared motors, right angle drives with motor, motorvariators and electric motors correspond to the specifications of the EMC directive.

Machinery Directive 2006/42/CE

GSM geared motors, right angle drives with motor, motorvariators and electric motors are not standalone machines, they are exclusively for installation into a machine or for assembly on a machine.

CE Mark, Conformity Declarations and Manufacturer's Declaration.

GSM geared motors, right angle drives with motor, motorvariators and electric motors carry the CE Mark.

It indicates conformity to the low voltage directive and to electromagnetic compatibility directive.

On request GSM supplies both the conformity declarations and the manufacturer's declaration according to the machine directive.

ISO 9001

GSM products have been designed and manufactured according to ISO 9001 quality system standard.

On request a copy of the certification can be

1.6.5 Standards applied

Gearing

Helical gear sets are first case hardened, hardened and tempered and finally their involute profile is ground.

Gleason bevel gear sets are first case hardened, hardened and tempered and finally broken in (or ground, depending on gear unit size).

Bearings

All bearings are high quality taper or self-aligning roller bearings suitably sized to ensure long service life provided the approved lubricants indicated in this catalogue are used.

Casing

Casings up to size 824-826 are cast from GJL 250 UNI EN 1561 cast iron or from Spheroidal cast iron.

Casing design incorporates special arrangements to provide superior rigidity.

1.6 Angewendete Normen

1.6.4 UE-Richtlinien - CE-Zeichen - ISO9001

Niederspannungsrichtlinie. 2014/35/UE

Die Getriebemotoren, Winkelgetriebe, Verstellgetriebe und Elektromotoren der GSM entsprechen den Vorschriften der Niederspannungsrichtlinie.

2014/30/UE Elektromagnetische Verträglichkeit

Die Getriebemotoren, Winkelgetriebe, Verstellgetriebe und Elektromotoren der GSM entsprechen den Vorschriften der Richtlinie zur Elektromagnetischen Verträglichkeit.

Maschinenrichtlinie 2006/42/CE

Die Getriebemotoren, Winkelgetriebe, Verstellgetriebe und Elektromotoren der GSM sind keine Maschinen sondern Organe, die in Maschinen eingebaut oder an diesen montiert werden.

CE-Zeichen, Hersteller- und Konformitätserklärung

Die Getriebemotoren, Verstellgetriebe und Elektromotoren tragen das CE-Zeichen.

Dieses Zeichen weist auf ihre Konformität mit der Niederspannungsrichtlinie und der Richtlinie zur Elektromagnetischen Verträglichkeit hin.

Auf Anfrage kann die GSM die Konformitätserklärung und die Herstellererklärung gemäß Maschinenrichtlinie zu den Produkten liefern.

ISO 9001

Die GSM-Produkte werden in einem Qualitätssystem gemäß dem Standard ISO 9001 realisiert. Auf Anfrage kann daher eine Kopie der Zertifizierung geliefert werden.

1.6.5 Bezugsnormen Entwicklung und Produktion

Zahnräder

Das Evolventenprofil der Stirnrädergetriebe mit Schrägverzahnung wird nach dem Einsatzhärten, dem Abschrecken und dem Anlassen entsprechend geschliffen.

Die Kegelhäuseräder mit Gleason-Verzahnung sind bereits eingelaufen (oder in Abhängigkeit der Getriebegröße geschliffen), dies erfolgt nach dem Einsatzhärten, Abschrecken

Lager

Bei allen Lagern handelt es sich um hochqualitative Kegelrollenlager mit orientierungsfähigen Rollen und in Maßen, die so ausgelegt sind, dass sie bei Einsatz der gemäß Katalogangaben vorgesehenen Schmiermittel eine lange Lebensdauer garantieren.

Gehäuse

Die Gehäuse der Getriebe bis Baugröße 824-826 werden im Gussverfahren aus GJL 250 UNI EN 1561 oder Sphäroguss UNI EN 1563 2004 gewonnen.

Die besonderen beim Entwurf der Struktur berücksichtigten Vorkehrungen verleihen ihr eine besondere Steifheit.

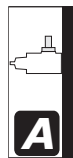

1.6 Normative applicate**Alberi**

Gli alberi lenti sono verificati a flessione-torsione con elevato coefficiente di sicurezza. Le estremità d'albero cilindriche sono secondo UNI 6397-68, DIN 748, NF E 22.051, BS 4506-70, ISO/R 775-69, escluso corrispondenza R-S, con foro filettato in testa secondo DIN 1414. Linguette secondo UNI 6604-69, DIN 6885 B1, 1-68, NF E 27.656 22.175, BS 4235.1-72, ISO/R 773-69 escluso corrispondenza I.

Tutti i prodotti della GSM sono progettati nel rispetto delle seguenti normative:

Calcolo degli ingranaggi

In corrispondenza alla "CTI CODE TOWER-STD-111" i dati espressi in questo catalogo, senza alcuna necessità di ulteriori fattori applicativi, soddisfano la condizione progettuale di durata di 100.000 ore di funzionamento secondo le seguenti normative abbinare ai corrispettivi fattori di applicazione - FS;
- FS=3.6 - ISO 10300:2001 METODO B e ISO 6336:2006 METODO B; e/o
- FS=3.8 - DIN 3991:1988 e DIN 3990:1987 METODO B; e/o
- FS=2 - AGMA 2003-C10 e AGMA 2001-C95

Calcolo dei cuscinetti

In corrispondenza alla "CTI CODE TOWER-STD-111" i dati espressi in questo catalogo soddisfano le seguenti condizioni progettuali di durata:
Asse di uscita: $L_{nm}=100.000$ ore minime di funzionamento
Asse entrata ed intermedio: $L_{nm}=50.000$ ore minime di funzionamento

L_{nm} = ISO 281 - Calcolo della durata a fatica dei cuscinetti volventi.

Alberi

DIN 743
Calcolo della durata a fatica degli alberi

Materiali

EN 10084
Acciaio da cementazione per ingranaggi e viti senza fine.

EN 10083
Acciaio da bonifica per alberi.

UNI EN 1706
Alluminio e leghe di Alluminio

UNI EN 1561
Fusioni in ghisa grigia.

UNI EN 1563 2004
Getti di ghisa a grafite sferoidale

UNI 3097
Acciaio per cuscinetti per piste rotolamento.

1.6 Standards applied**Shafts**

Output shafts are calculations incorporate a high safety factor and are validated by bending and torsional stress analyses. Cylindrical shaft ends are in accordance with UNI 6397-68, DIN 748, NF E 22.051, BS 4506-70, ISO/R 775-69, excluding section R-S, with centre tapped hole at shaft end to DIN 1414. Keys are in accordance with UNI 6604-69, DIN 6885 B1, 1-68, NF E27.656 22.175, BS 4235.1-72, ISO/R 773-69 excluding section I.

All GSM products are designed following these standards:

Calculation of gear

*According to the "CTI CODE TOWER-STD-111" the data shown in this catalog, without any need of further application factors, satisfy the design condition of operating lifetime of 100,000 hours according to following standards matched to the corresponding factors of application - FS;
- FS=3.6 - ISO 10300:2001 METODO B e ISO 6336:2006 METODO B; e/o
- FS=3.8 - DIN 3991:1988 e DIN 3990:1987 METODO B; e/o
- FS=2 - AGMA 2003-C10 e AGMA 2001-C95*

Calculation of bearings

According to the "CTI CODE TOWER-STD-111" the data shown in this catalog meet the following design conditions of lifetime:

*Output axis: $L_{nm}= 100.000$ hours min. of operation
Input and intermediate axis: $L_{nm}= 50.000$ hours min. of operation*

L_{nm} = ISO 281 - ISO 281 - Rolling bearings
Dynamic load ratings and rating life

Shafts

DIN743
Shafts — Dynamic load ratings and rating life

Materials

EN 10084
Case hardening steels for gears and worms

EN 10083
Quenched and Tempered Steels for shafts

UNI EN 1706
Aluminium alloy

UNI EN 1561
Grey iron casting

UNI EN 1563 2004
Spheroidal cast iron

UNI 3097
Ball and roller bearing steel

1.6 Angewendete Normen**Wellen**

Die Abtriebswellen werden unter Berücksichtigung eines hohen Sicherheitskoeffizienten auf Biegung-Windung getestet. Die Enden der zylindrischen Wellen entsprechen den Normen UNI 6397-68, DIN 748, NF E 22.051, BS 4506-70, ISO/R 775-69, ausgenommen Zuordnung R-S, mit Gewindebohrung in der Wellenspitze DIN 1414. Die Federkeile entsprechen UNI 6604-69, DIN 6885 B1, 1-68, NF E 27.656 22.175, BS 4235.1-72, ISO/R 773-69, ausgenommen Zuordnung I.

Alle Produkte der GSM werden unter Einhaltung folgender Normen entwickelt:

Berechnung der Zahnräder und Lager

Gemäß der "CTI CODE TOWER-STD-111" sind die Angaben in diesem Katalog, ohne Notwendigkeit weiterer Anwendungsfaktoren, erfüllend für die Bedingung der Lebensdauer von 100.000 Betriebsstunden und nach folgenden Normen zu den entsprechenden Anwendungsfaktoren abgestimmt - FS;
- FS=3.6 - ISO 10300:2001 METODO B e ISO 6336:2006 METODO B; e/o
- FS=3.8 - DIN 3991:1988 e DIN 3990:1987 METODO B; e/o
- FS=2 - AGMA 2003-C10 e AGMA 2001-C95

Berechnung der und Lager

In Übereinstimmung mit dem "CTI CODE TOWER-STD-111" erfüllen die Angaben in diesem Katalog die folgenden Lebensdauerbedingungen
Abtriebswelle: $L_{nm} = 100.000$ Stunden minimaler Gebrauch
Antriebswelle: $L_{nm} = 50.000$ Stunden minimaler Gebrauch

L_{nm} = ISO 281 - Berechnung der Belastungsdauer der Wälzlager.

Wellen

DIN743
Berechnung der Belastungsdauer der Wellen.

Material

EN 10084
Einsatzstahl für Zahnräder und Schnecken.

EN 10083
Vergütungsstahl für Wellen.

UNI EN 1706
Aluminium und Aluminiumlegierungen

UNI EN 1561
Grauguss-Legierungen

UNI EN 1563 2004
Sphäroguss

UNI 3097
Stahl für Lagergleitbahnen





1.7 Designazione

1.7 Designation

1.7 Bezeichnung

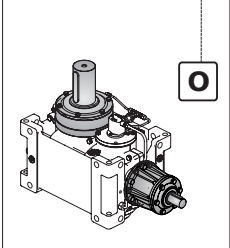
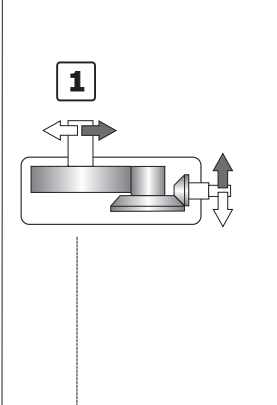
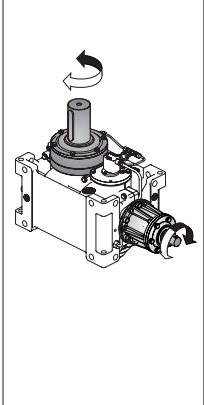
CODE: Example of Order	RX	O	1	804	BS	6.77
	Maschine 00-M	Centerline Orientation 01-CO	N° of reductions 02-NOR	Size 03-SIZE	Shaft arrangement 04-SA	Reduction ratio 05-IR

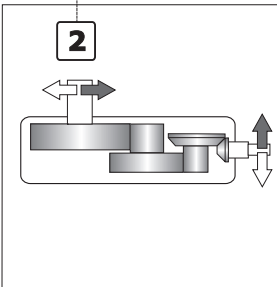
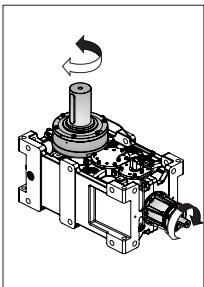
 <p>0</p>	 <p>1</p>	<p>802 804 806 808 810 812 814 816 818 820 822 824</p>	 <p>BS</p>	 <p>Table</p>
	 <p>2</p>	<p>814 816 818 820</p>		

1.7 Designazione

1.7 Designation

1.7 Bezeichnung

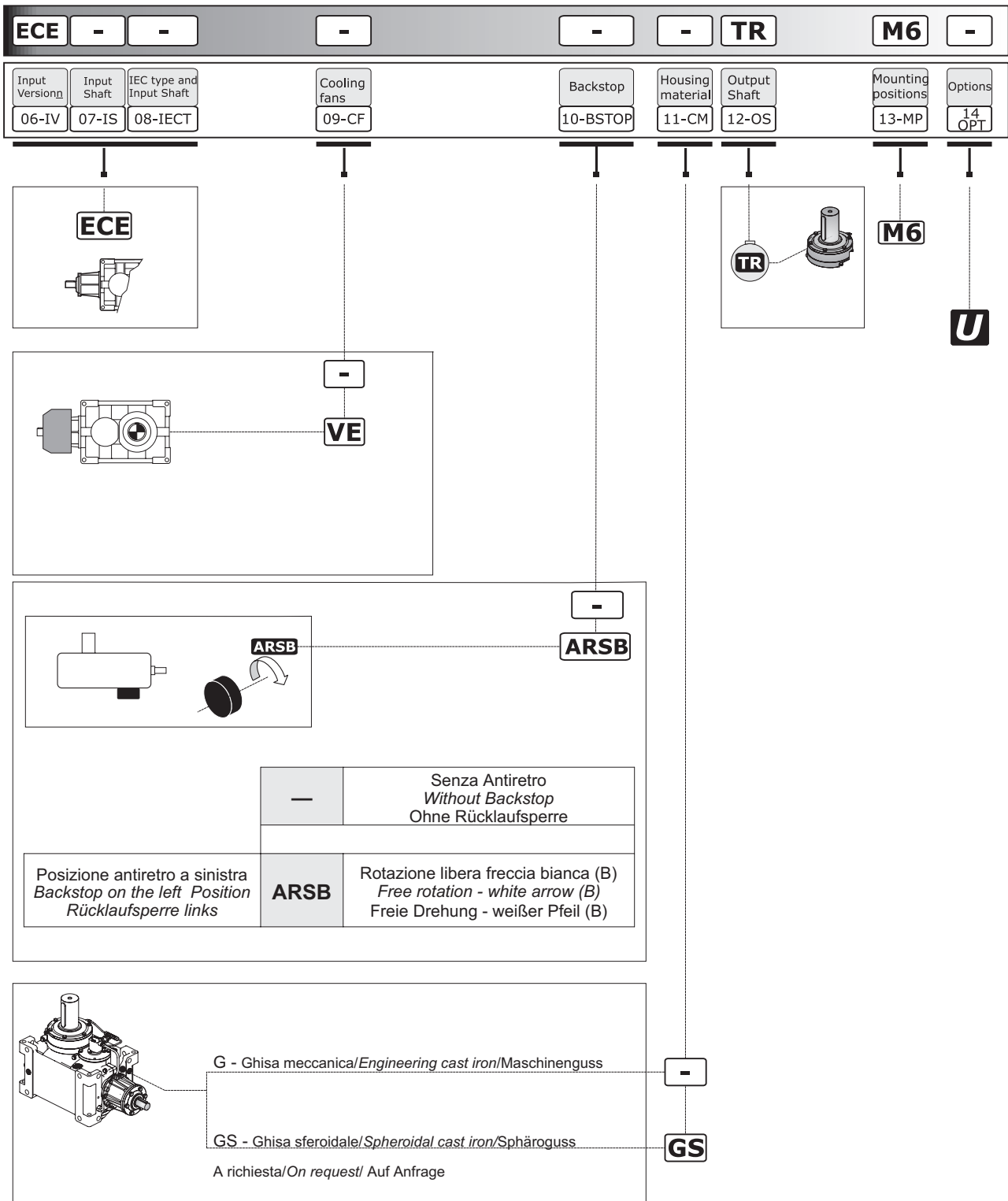

1.8 Lubrificazione

Gli oli consigliati per i riduttori della serie RX per applicazione TR sono di tipo sintetico a base di Poli-Alfa-Oleofine (PAO); ogni costruttore di olio realizza però il proprio prodotto con indici di viscosità ed additivazioni differenti.

Per facilitare la scelta del lubrificante, GSM ha realizzato una tabella riassuntiva che, a seconda delle condizioni applicative del riduttore, indica gli oli più consoni di diversi brand presenti sul mercato.

1.8 Lubrication

The best suitable oil for RX gearbox series for TR application are synthetic and containing poly-Alpha-Olefin (PAO). As a matter of fact each oil producer creates his own product with different viscosity indexes and additives.

For this reason GSM has created a list with all brands of suitable lubricants which are available on the market, also taking into consideration the many different conditions of the gearbox applications.

1.8 Schmierung

Die empfohlenen Öle für Getriebe der RX Serie für die TR-Anwendungen basieren auf synthetischen Poly-Alpha-Olefinen (PAO). Allerdings hat jeder Ölhersteller eigene Angaben zu Viskosität und Additiven.

Um die Wahl des Schmiermittels zu erleichtern, hat GSM eine Übersichtstabelle realisiert, die abhängig von den Einsatzbedingungen der Getriebe sind. Angegeben werden die geeignetsten Öle verschiedener Marken auf dem Markt.

Viscosity ISO VG at 40° (cSt)		ZONE RANGE - OPTZ Ambient Temperature - Ta - [°C]					
		ZONE STANDARD				ZONE MULTIGRADE	
RANGE	1750 < n ₁ ≤ 1000	68	100	150	220	—	220
Input speed - n₁ [min ⁻¹]	1000 < n ₁ ≤ 500	68	100	150	220	100	220
HEATERS		without applying any heaters					

	Viscosity - ISO VG at 40° (cSt) - CLP -HC TYPE OILS - (PAO) Poly-Alpha-Olefin synthetic			
	68	100	150	220
	—	—	Degol PAS 150	Degol PAS 220
	—	—	Meropa Synthetic EP 150	Meropa Synthetic EP 220
	Optigear Synthetic PD 68	Optigear Synthetic X 100	Optigear Synthetic X 150	Optigear Synthetic X 220
	—	—	Meropa Synthetic EP 150	Meropa Synthetic EP 220
	—	—	Agip Blasia FSX 150	Agip Blasia FSX 220
	Renolin Unisyn CLP 68	Renolin Unisyn CLP 100	Renolin Unisyn CLP 150	Renolin Unisyn CLP 220
	—	Renolin Unisyn XT 100	Renolin Unisyn XT 150	Renolin Unisyn XT 220
	Klübersynth GEM 4 - 68 N	Klübersynth GEM 4 - 100 N	Klübersynth EG4-150	Klübersynth EG4-220
	—	—	Klübersynth GEM 4 - 150 N	Klübersynth GEM 4 - 220 N
	—	—	Mobilgear SHC XMP 150	Mobilgear SHC XMP 220
	—	—	Gear Syn PAO 150	Gear Syn PAO 220
	—	—	OMALA S4 GX 150	OMALA S4 GX 220
	—	—	Meropa Synthetic EP 150	Meropa Synthetic EP 220
	—	—	Carter SH 150	Carter SH 220

1.8 Lubrificazione

1.8 Lubrication

1.8 Schmierung

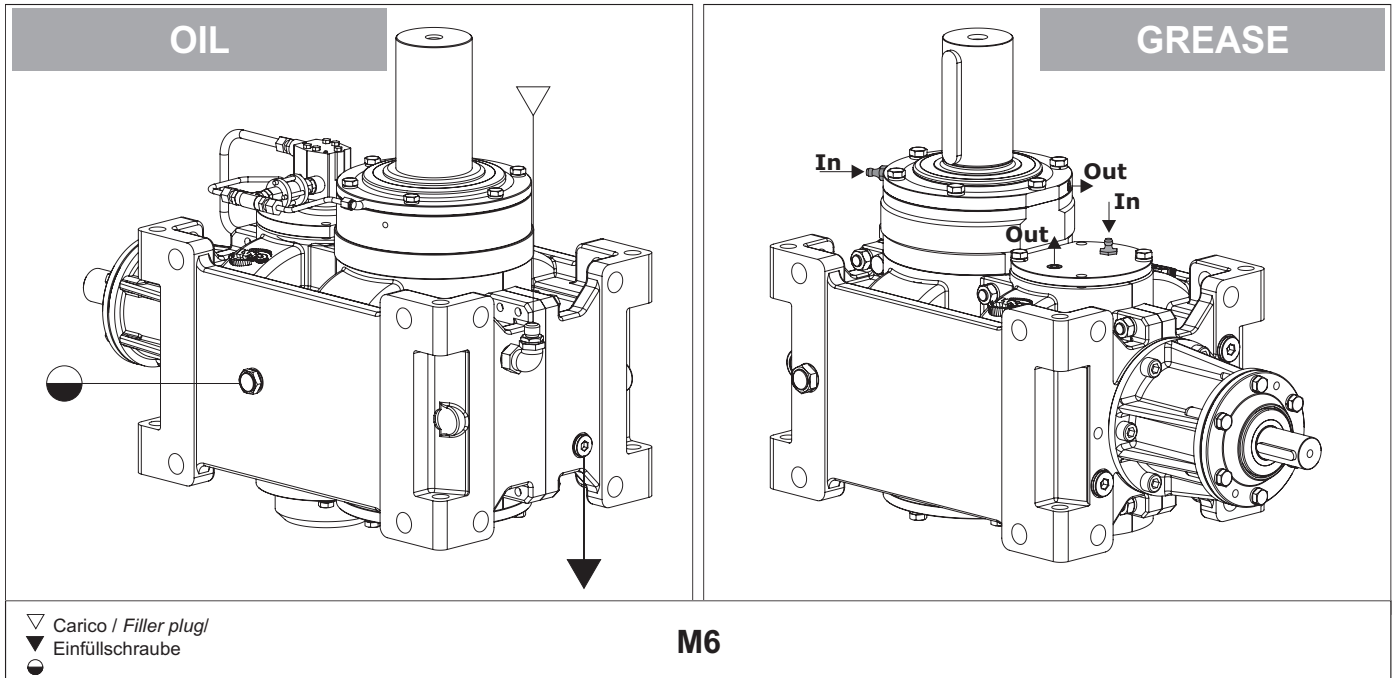

	Quantità di lubrificante / Lubricant Quantity / Schmiermittelmenge (l)											
	802	804	806	808	810	812	814	816	818	820	822	824
RXO1	3,6	5,0	7,1	10,0	14,0	20,0	29,0	40,0	57,0	79,0	110,0	151,0
RXO2			—				35,0	50,0	70,0	99,0		—

Le quantità di olio sono approssimative; per una corretta lubrificazione occorre fare riferimento al livello segnato sul riduttore.
ATTENZIONE
 Eventuali forniture con predisposizioni tappi diverse da quella indicata in tabella, dovranno essere concordate.

Oil quantities listed in the table are approximate; to ensure correct lubrication, please refer to the level mark on the gear unit.
WARNING
 Any plug arrangements other than that indicated in the table must be agreed upon.

Bei den Ölmengeangaben handelt es sich um approximative Werte; für den Erhalt einer korrekten Schmierung muss Bezug auf den am Getriebe gekennzeichneten Füllstand genommen werden.
ACHTUNG
 Eventuelle Lieferungen mit einer von den Tabellenangaben abweichenden Anordnung der Stopfen müssen zuvor abgestimmt werden.

Lubrificazione cuscinetti superiori

Qualora i cuscinetti superiori lubrificati siano forniti lubrificati a grasso è necessario provvedere al ringrassaggio ogni 6 (sei) mesi di funzionamento.

Se ne consiglia il ringrassaggio indipendentemente dalle ore di esercizio effettuate, dopo almeno 2-3 anni

Pertanto è stato predisposto un ingrassatore per provvedere all'opportuno ringrassaggio (secondo lo schema vedere la freccia In) ed un corrispondente valvola di scarico per effettuare il corretto spurgo (secondo lo schema vedere la freccia Out).

Upper bearing lubrication

Whenever the upper bearings are grease lubricated is necessary the regreasing every 6 (six) months of operation.

It is recommended to grease it at least every 2-3 years regardless of the operating hours

Therefore a grease plug has been arranged to proceed with the regreasing (according to the scheme see arrow in) and a corresponding valve to make the correct draining (according to the scheme see arrow Out).

Schmierung der obenliegenden Lager

Wenn die oberen Lager fettgeschmiert geliefert werden, ist es erforderlich, alle 6 (sechs) Gebrauchsmonate die Lager nachzuschmieren.

Wir empfehlen, unabhängig von den erfolgten Betriebsstunden, mindestens alle 2-3 Jahre ein entsprechendes Nachschmieren

Deshalb wurden entsprechende Schmiernippel vorgesehen, um eine korrekte Nachschmierung zu ermöglichen (gemäß dem Schema siehe Pfeil In) und ein entsprechendes Auslassventil, um eine korrekte Reinigung zu erwirken (gemäß dem Schema siehe Pfeil Out).

	Grandezza / Size / Baugröße											
	802	804	806	808	810	812	814	816	818	820	822	824
$n_1 \geq n_{1min}$	-			LFP3								
$n_1 < n_{1min}$	G (grease)											
	G (grease)											

I valori di n_{1min} sono riportati nel paragrafo Verifiche, punto 1.

n_{1min} values are listed at paragraph Verification, point 1.

Die Werte von n_{1min} werden im Paragraph "Kontrollen", Punkt 1, angegeben.

1.9 Prestazioni riduttori

1.9 Gear unit ratings

1.9 Leistungen der Getriebe

RX01 802		Calculation of gear - Service Factor: 3.6-ISO; 3.8-DIN; 2.0 - AGMA					Calculation of bearings - hours min - ISO 281 Output axis: 100.000 - Others axis: 50.000					82													
ir	J1 kgm ²	n₁ = 1750 min⁻¹					n₁ = 1450 min⁻¹					n₁ = 1160 min⁻¹					n₁ = 970 min⁻¹								
		n ₂ min ⁻¹	P kW	T _N Nm	Fr ₁ kN	Fr ₂ kN	Fa ₂ kN	n ₂ min ⁻¹	P kW	T _N Nm	Fr ₁ kN	Fr ₂ kN	Fa ₂ kN	n ₂ min ⁻¹	P kW	T _N Nm	Fr ₁ kN	Fr ₂ kN	Fa ₂ kN	n ₂ min ⁻¹	P kW	T _N Nm	Fr ₁ kN	Fr ₂ kN	Fa ₂ kN
4,08	0,0023	429	25,5	540	0,73	1,00	15,1	355	22,0	562	0,73	1,00	15,1	284	18,5	591	0,73	1,00	15,1	238	15,3	584	0,73	1,00	15,1
4,40	0,0022	398	25,5	582	0,73	0,95	15,1	329	22,0	606	0,73	0,95	15,1	264	18,5	637	0,73	0,95	15,1	220	15,3	630	0,73	0,95	15,1
5,22	0,0021	335	25,5	690	0,75	0,70	15,1	278	22,0	719	0,75	0,70	15,1	222	18,5	755	0,75	0,70	15,1	186	15,3	747	0,75	0,70	15,1
5,54	0,0020	316	25,5	732	0,80	0,70	15,1	262	22,0	762	0,80	0,70	15,1	209	18,5	801	0,80	0,70	15,1	175	15,3	793	0,80	0,70	15,1
6,26	0,0019	279	25,5	828	0,83	0,70	15,0	232	22,0	862	0,83	0,70	15,0	185	17,6	862	0,83	0,70	15,0	155	15,0	878	0,83	0,70	15,0
7,13	0,0018	245	25,3	935	0,88	1,00	13,7	203	22,0	981	0,88	1,00	13,7	163	16,5	920	0,88	1,00	13,7	136	13,5	900	0,88	1,00	13,7
7,63	0,0017	229	24,2	957	0,90	1,00	13,7	190	20,3	969	0,90	1,00	13,7	152	15,9	949	0,90	1,00	13,7	127	13,1	935	0,90	1,00	13,7
8,81	0,0016	199	22,4	1024	0,95	1,00	13,7	165	18,7	1031	0,95	1,00	13,7	132	15,0	1034	0,95	1,00	13,7	110	12,0	989	0,95	1,00	13,7
9,52	0,0016	184	22,0	1085	0,98	1,00	13,7	152	18,5	1101	0,98	1,00	13,7	122	14,0	1042	0,98	1,00	13,7	102	11,5	1024	0,98	1,00	13,7
11,22	0,0015	156	19,2	1117	1,03	1,00	13,2	129	16,1	1130	1,03	1,00	13,2	103	12,5	1097	1,03	1,00	13,2	86	10,3	1081	1,03	1,00	13,2
12,27	0,0014	143	18,5	1177	1,05	1,00	12,7	118	15,2	1167	1,05	1,00	12,7	95	11,8	1132	1,05	1,00	12,7	79	9,6	1102	1,05	1,00	12,7
13,26	0,0014	132	14,1	969	1,05	1,00	12,7	109	11,5	954	1,05	1,00	12,7	87	9,2	954	1,05	1,00	12,7	73	7,5	930	1,05	1,00	12,7
14,32	0,0014	122	13,6	1007	1,10	1,00	12,9	101	11,0	985	1,10	1,00	12,9	81	8,6	963	1,10	1,00	12,9	68	7,5	1004	1,10	1,00	12,9
16,88	0,0013	104	12,3	1075	1,13	1,00	12,9	86	10,0	1056	1,13	1,00	12,9	69	7,9	1043	1,13	1,00	12,9	57	6,5	1026	1,13	1,00	12,9
18,46	0,0013	95	11,5	1101	1,18	1,00	12,8	79	9,4	1086	1,18	1,00	12,8	63	7,5	1083	1,18	1,00	12,8	53	6,0	1036	1,18	1,00	12,8
20,08	0,0013	87	9,2	958	1,20	0,70	12,7	72	7,6	955	1,20	0,70	12,7	58	6,0	942	1,20	0,70	12,7	48	5,0	939	1,20	0,70	12,7
23,68	0,0012	74	8,4	1031	1,25	0,70	12,4	61	6,8	1007	1,25	0,70	12,4	49	5,5	1019	1,25	0,70	12,4	41	4,5	997	1,25	0,70	12,4
25,89	0,0008	68	8,0	1074	1,28	0,70	12,2	56	6,5	1053	1,28	0,70	12,2	45	5,2	1053	1,28	0,70	12,2	37	4,2	1017	1,28	0,70	12,2

Potenze termiche / Thermal power / Thermische Grenzleistung PtN [kW] (senza raffreddamento / Without cooling / ohne Kühlung)
30

RX01 804		Calculation of gear - Service Factor: 3.6-ISO; 3.8-DIN; 2.0 - AGMA					Calculation of bearings - hours min - ISO 281 Output axis: 100.000 - Others axis: 50.000					114													
ir	J1 kgm ²	n₁ = 1750 min⁻¹					n₁ = 1450 min⁻¹					n₁ = 1160 min⁻¹					n₁ = 970 min⁻¹								
		n ₂ min ⁻¹	P kW	T _N Nm	Fr ₁ kN	Fr ₂ kN	Fa ₂ kN	n ₂ min ⁻¹	P kW	T _N Nm	Fr ₁ kN	Fr ₂ kN	Fa ₂ kN	n ₂ min ⁻¹	P kW	T _N Nm	Fr ₁ kN	Fr ₂ kN	Fa ₂ kN	n ₂ min ⁻¹	P kW	T _N Nm	Fr ₁ kN	Fr ₂ kN	Fa ₂ kN
4,06	0,0039	431	34,8	732	0,90	1,00	19,5	357	30,0	761	0,90	1,00	19,5	286	24,4	774	0,90	1,00	19,5	239	22,0	835	0,90	1,00	19,5
4,39	0,0039	399	34,8	791	0,90	1,00	19,5	331	30,0	823	0,90	1,00	19,5	264	24,4	837	0,90	1,00	19,5	221	22,0	902	0,90	1,00	19,5
4,93	0,0037	355	34,8	889	0,95	1,00	19,5	294	30,0	925	0,95	1,00	19,5	235	24,4	941	0,95	1,00	19,5	197	22,0	1014	0,95	1,00	19,5
5,57	0,0035	314	34,8	1005	1,00	1,00	19,5	260	30,0	1045	1,00	1,00	19,5	208	24,4	1063	1,00	1,00	19,5	174	22,0	1146	1,00	1,00	19,5
5,93	0,0033	295	34,8	1070	1,05	1,00	19,1	244	30,0	1113	1,05	1,00	19,1	196	24,4	1132	1,05	1,00	19,1	164	22,0	1221	1,05	1,00	19,1
6,77	0,0032	259	34,8	1221	1,10	1,00	19,1	214	30,0	1270	1,10	1,00	19,1	171	24,4	1291	1,10	1,00	19,1	143	20,8	1316	1,10	1,00	19,1
7,25	0,0031	241	34,8	1308	1,15	1,00	18,7	200	30,0	1361	1,15	1,00	18,7	160	24,4	1384	1,15	1,00	18,7	134	20,1	1363	1,15	1,00	18,7
8,39	0,0029	209	33,9	1474	1,20	1,00	18,7	173	30,0	1574	1,20	1,00	18,7	138	22,4	1469	1,20	1,00	18,7	116	18,5	1451	1,20	1,00	18,7
9,83	0,0028	178	30,7	1564	1,25	1,00	18,3	148	26,4	1623	1,25	1,00	18,3	118	20,5	1576	1,25	1,00	18,3	99	16,6	1526	1,25	1,00	18,3
10,70	0,0027	164	30,0	1665	1,30	1,00	18,3	135	24,9	1667	1,30	1,00	18,3	108	19,4	1624	1,30	1,00	18,3	91	15,8	1582	1,30	1,00	18,3
11,71	0,0025	149	27,5	1670	1,33	1,00	18,0	124	23,5	1722	1,33	1,00	18,0	99	18,5	1695	1,33	1,00	18,0	83	15,0	1643	1,33	1,00	18,0
12,89	0,0025	136	25,6	1711	1,35	1,00	18,0	113	22,0	1774	1,35	1,00	18,0	90	17,1	1724	1,35	1,00	18,0	75	13,9	1676	1,35	1,00	18,0
14,79	0,0025	118	20,0	1533	1,40	1,00	17,1	98	16,1	1490	1,40	1,00	17,1	78	12,6	1457	1,40	1,00	17,1	66	11,0	1521	1,40	1,00	17,1
16,10	0,0024	109	18,9	1578	1,55	1,00	17,1	90	15,3	1542	1,55	1,00	17,1	72	12,0	1511	1,55	1,00	17,1	60	9,9	1491	1,55	1,00	17,1
17,62	0,0023	99	17,6	1608	1,45	1,00	15,7	82	15,0	1654	1,45	1,00	15,7	66	11,3	1557	1,45	1,00	15,7	55	9,3	1533	1,45	1,00	15,7
19,39	0,0022	90	16,7	1679	1,48	1,00	15,7	75	13,5	1638	1,48	1,00	15,7	60	11,0	1669	1,48	1,00	15,7	50	8,7	1578	1,48	1,00	15,7
20,74	0,0022	84	12,6	1355	1,50	1,00	15,7	70	11,0	1427	1,50	1,00	15,7	56	8,7	1411	1,50	1,00	15,7	47	7,5	1455	1,50	1,00	15,7
22,59	0,0022	77	12,6	1475	1,55	1,00	16,5	64	11,0	1554	1,55	1,00	16,5	51	8,4	1480	1,55	1,00	16,5	43	6,9	1458	1,55	1,00	16,5
24,72	0,0014	71	12,3	1576	1,60	1,00	15,8	59	10,0	1546	1,60	1,00	15,8	47	7,9	1527	1,60	1,00	15,8	39	6,5	1503	1,60	1,00	15,8

Potenze termiche / Thermal power / Thermische Grenzleistung PtN [kW] (senza raffreddamento / Without cooling / ohne Kühlung)
39

1.9 Prestazioni riduttori

1.9 Gear unit ratings

1.9 Leistungen der Getriebe

RX01 806

Calculation of gear - Service Factor:
3.6-ISO; 3.8-DIN; 2.0 - AGMA

Calculation of bearings - hours min - ISO 281
Output axis: 100.000 - Others axis: 50.000



154



ir	J1 kgm ²	n ₁ = 1750 min ⁻¹						n ₁ = 1450 min ⁻¹						n ₁ = 1160 min ⁻¹						n ₁ = 970 min ⁻¹					
		n ₂ min ⁻¹	P kW	T _N Nm	Fr ₁ kN	Fr ₂ kN	Fa ₂ kN	n ₂ min ⁻¹	P kW	T _N Nm	Fr ₁ kN	Fr ₂ kN	Fa ₂ kN	n ₂ min ⁻¹	P kW	T _N Nm	Fr ₁ kN	Fr ₂ kN	Fa ₂ kN	n ₂ min ⁻¹	P kW	T _N Nm	Fr ₁ kN	Fr ₂ kN	Fa ₂ kN
4,06	0,0070	431	46,7	982	1,15	1,00	18,1	357	39,8	1010	1,15	1,00	18,1	286	32,8	1041	1,15	1,00	18,1	239	28,4	1078	1,15	1,00	18,1
4,39	0,0070	399	46,7	1062	1,15	1,00	18,1	331	39,8	1092	1,15	1,00	18,1	264	32,8	1125	1,15	1,00	18,1	221	28,4	1165	1,15	1,00	18,1
4,93	0,0066	355	46,7	1194	1,15	1,00	18,1	294	39,8	1228	1,15	1,00	18,1	235	32,8	1265	1,15	1,00	18,1	197	28,4	1310	1,15	1,00	18,1
5,57	0,0066	314	46,7	1348	1,23	0,50	17,9	260	39,8	1387	1,23	0,50	17,9	208	32,8	1429	1,23	0,50	17,9	174	28,4	1479	1,23	0,50	17,9
5,93	0,0063	295	46,7	1436	1,28	1,00	15,6	244	39,8	1477	1,28	1,00	15,6	196	32,8	1522	1,28	1,00	15,6	164	28,4	1576	1,28	1,00	15,6
6,77	0,0060	259	46,7	1638	1,35	0,70	15,6	214	39,8	1685	1,35	0,70	15,6	171	32,8	1736	1,35	0,70	15,6	143	28,4	1797	1,35	0,70	15,6
7,25	0,0058	241	46,7	1755	1,40	1,00	14,4	200	39,8	1805	1,40	1,00	14,4	160	32,8	1860	1,40	1,00	14,4	134	28,4	1926	1,40	1,00	14,4
8,39	0,0054	209	46,7	2031	1,48	0,50	13,6	173	39,8	2089	1,48	0,50	13,6	138	32,8	2152	1,48	0,50	13,6	116	28,4	2228	1,48	0,50	13,6
9,83	0,0052	178	46,7	2379	1,53	0,50	11,7	148	39,8	2447	1,53	0,50	11,7	118	32,8	2521	1,53	0,50	11,7	99	28,4	2611	1,53	0,50	11,7
10,70	0,0049	164	46,7	2591	1,60	0,50	10,6	135	39,8	2665	1,60	0,50	10,6	108	32,8	2746	1,60	0,50	10,6	91	28,4	2843	1,60	0,50	10,6
11,71	0,0048	149	46,7	2835	1,68	1,00	9,3	124	39,5	2894	1,68	1,00	9,3	99	31,9	2922	1,68	1,00	9,3	83	26,8	2936	1,68	1,00	9,3
12,89	0,0048	136	39,6	2646	1,78	1,00	9,3	113	33,1	2669	1,78	1,00	9,3	90	26,7	2692	1,78	1,00	9,3	75	22,8	2749	1,78	1,00	9,3
14,79	0,0045	118	28,2	2162	1,90	1,00	10,0	98	23,7	2193	1,90	1,00	10,0	78	19,8	2290	1,90	1,00	10,0	66	17,1	2365	1,90	1,00	10,0
16,10	0,0044	109	28,2	2354	1,78	1,00	10,0	90	23,7	2388	1,78	1,00	10,0	72	19,8	2494	1,78	1,00	10,0	60	17,1	2576	1,78	1,00	10,0
17,62	0,0042	99	28,2	2576	1,85	1,00	8,5	82	23,7	2613	1,85	1,00	8,5	66	19,8	2729	1,85	1,00	8,5	55	17,1	2818	1,85	1,00	8,5
19,39	0,0041	90	27,5	2765	1,88	1,00	8,5	75	22,8	2767	1,88	1,00	8,5	60	18,6	2821	1,88	1,00	8,5	50	15,7	2848	1,88	1,00	8,5
20,74	0,0040	84	17,0	1828	1,90	1,00	8,5	70	15	1947	1,90	1,00	8,5	56	11,9	1930	1,90	1,00	8,5	47	10,1	1959	1,90	1,00	8,5
22,59	0,0040	77	17,0	1991	1,98	1,00	8,9	64	15	2120	1,98	1,00	8,9	51	11,9	2102	1,98	1,00	8,9	43	10,1	2134	1,98	1,00	8,9
24,72	0,0039	71	17,0	2178	2,03	1,00	8,9	59	15	2320	2,03	1,00	8,9	47	11,9	2300	2,03	1,00	8,9	39	10,1	2335	2,03	1,00	8,9

Potenze termiche / Thermal power / Thermische Grenzleistung PtN [kW]

(senza raffreddamento / Without cooling / ohne Kühlung)

51

RX01 808

Calculation of gear - Service Factor:
3.6-ISO; 3.8-DIN; 2.0 - AGMA

Calculation of bearings - hours min - ISO 281
Output axis: 100.000 - Others axis: 50.000



211

ir	J1 kgm ²	n ₁ = 1750 min ⁻¹						n ₁ = 1450 min ⁻¹						n ₁ = 1160 min ⁻¹						n ₁ = 970 min ⁻¹					
		n ₂ min ⁻¹	P kW	T _N Nm	Fr ₁ kN	Fr ₂ kN	Fa ₂ kN	n ₂ min ⁻¹	P kW	T _N Nm	Fr ₁ kN	Fr ₂ kN	Fa ₂ kN	n ₂ min ⁻¹	P kW	T _N Nm	Fr ₁ kN	Fr ₂ kN	Fa ₂ kN	n ₂ min ⁻¹	P kW	T _N Nm	Fr ₁ kN	Fr ₂ kN	Fa ₂ kN
4,06	0,0130	431	60,4	1270	1,7	1,00	22,2	357	51,8	1315	1,7	1,00	22,2	286	42,5	1348	1,7	1,00	22,2	239	37	1404	1,7	1,00	22,2
4,39	0,0125	399	60,4	1373	1,7	1,00	22,2	331	51,8	1421	1,7	1,00	22,2	264	42,5	1458	1,7	1,00	22,2	221	37	1518	1,7	1,00	22,2
4,93	0,0118	355	60,4	1544	1,7	1,00	22,2	294	51,8	1598	1,7	1,00	22,2	235	42,5	1639	1,7	1,00	22,2	197	37	1706	1,7	1,00	22,2
5,57	0,0112	314	60,4	1744	1,8	1,00	22,2	260	51,8	1805	1,8	1,00	22,2	208	42,5	1851	1,8	1,00	22,2	174	37	1927	1,8	1,00	22,2
6,33	0,0106	276	60,4	1982	1,8	1,00	21,5	229	51,8	2051	1,8	1,00	21,5	183	42,5	2104	1,8	1,00	21,5	153	37	2190	1,8	1,00	21,5
7,25	0,0102	241	60,4	2270	1,9	1,00	18,7	200	51,8	2350	1,9	1,00	18,7	160	42,5	2410	1,9	1,00	18,7	134	37	2509	1,9	1,00	18,7
7,79	0,0097	225	60,4	2438	2,0	1,00	18,7	186	51,8	2524	2,0	1,00	18,7	149	42,5	2588	2,0	1,00	18,7	125	37	2695	2,0	1,00	18,7
9,06	0,0092	193	60,4	2838	2,0	0,50	18,3	160	51,8	2937	2,0	0,50	18,3	128	42,5	3012	2,0	0,50	18,3	107	37	3136	2,0	0,50	18,3
9,83	0,0088	178	60,4	3077	2,1	1,00	15,5	148	51,8	3185	2,1	1,00	15,5	118	42,5	3267	2,1	1,00	15,5	99	37	3401	2,1	1,00	15,5
10,70	0,0085	164	60,4	3351	2,2	0,70	15,5	135	51,8	3469	2,2	0,70	15,5	108	42,5	3557	2,2	0,70	15,5	91	37	3704	2,2	0,70	15,5
11,71	0,0080	149	60,4	3667	2,2	1,00	10,9	124	51,8	3796	2,2	1,00	10,9	99	42,5	3893	2,2	1,00	10,9	83	37	4053	2,2	1,00	10,9
12,89	0,0080	136	56,8	3795	2,3	1,00	10,9	113	47,8	3855	2,3	1,00	10,9	90	38,8	3911	2,3	1,00	10,9	75	32,8	3954	2,3	1,00	10,9
14,79	0,0078	118	37	2837	2,3	1,00	10,9	98	30,3	2804	2,3	1,00	10,9	78	24,9	2880	2,3	1,00	10,9	66	22	3043	2,3	1,00	10,9
16,10	0,0075	109	37	3089	2,3	1,00	10,9	90	30,3	3053	2,3	1,00	10,9	72	24,9	3136	2,3	1,00	10,9	60	22	3314	2,3	1,00	10,9
17,62	0,0074	99	37	3380	2,4	1,00	10,0	82	30,3	3341	2,4	1,00	10,0	66	24,9	3432	2,4	1,00	10,0	55	22	3626	2,4	1,00	10,0
19,39	0,0074	90	37	3720	2,4	1,00	10,0	75	30,3	3677	2,4	1,00	10,0	60	24,9	3777	2,4	1,00	10,0	50	22	3991	2,4	1,00	10,0
20,74	0,0070	84	23,4	2516	2,5	1,00	10,0	70	19,9	2582	2,5	1,00	10,0	56	16,4	2660	2,5	1,00	10,0	47	14,1	2735	2,5	1,00	10,0
22,59	0,0069	77	23,4	2740	2,5	1,00	9,9	64	19,9	2812	2,5	1,00	9,9	51	16,4	2897	2,5	1,00	9,9	43	14,1	2979	2,5	1,00	9,9
24,72	0,0043	71	23,4	2998	2,6	1,00	9,9	59	19,9	3077	2,6	1,00	9,9	47	16,4	3170	2,6	1,00	9,9	39	14,1	3259	2,6	1,00	9,9
27,20	0,0042	64	23,4	3300	2,7	1,00	9,9	53	19,9	3387	2,7	1,00	9,9	43	16,4	3489	2,7	1,00	9,9	36	14,1	3587	2,7	1,00	9,9

Potenze termiche / Thermal power / Thermische Grenzleistung PtN [kW]

(senza raffreddamento / Without cooling / ohne Kühlung)

66

1.9 Prestazioni riduttori

1.9 Gear unit ratings

1.9 Leistungen der Getriebe

RX01 810

Calculation of gear - Service Factor:
3.6-ISO; 3.8-DIN; 2.0 - AGMA

Calculation of bearings - hours min - ISO 281
Output axis: 100.000 - Others axis: 50.000



292

ir	J1 kgm ²	n ₁ = 1750 min ⁻¹					n ₁ = 1450 min ⁻¹					n ₁ = 1160 min ⁻¹					n ₁ = 970 min ⁻¹								
		n ₂ min ⁻¹	P kW	T _N Nm	Fr ₁ kN	Fr ₂ kN	Fa ₂ kN	n ₂ min ⁻¹	P kW	T _N Nm	Fr ₁ kN	Fr ₂ kN	Fa ₂ kN	n ₂ min ⁻¹	P kW	T _N Nm	Fr ₁ kN	Fr ₂ kN	Fa ₂ kN	n ₂ min ⁻¹	P kW	T _N Nm	Fr ₁ kN	Fr ₂ kN	Fa ₂ kN
4,06	0,0240	431	90,7	1909	1,98	2,00	41,0	357	77,4	1966	1,98	2,00	41,0	286	64,6	2051	1,98	2,00	41,0	239	55,8	2119	1,98	2,00	41,0
4,39	0,0220	399	90,7	2062	1,98	2,00	41,0	331	77,4	2124	1,98	2,00	41,0	264	64,6	2216	1,98	2,00	41,0	221	55,8	2289	1,98	2,00	41,0
4,93	0,0209	355	90,7	2318	2,08	2,00	41,0	294	77,4	2388	2,08	2,00	41,0	235	64,6	2491	2,08	2,00	41,0	197	55,8	2573	2,08	2,00	41,0
5,57	0,0198	314	90,7	2619	2,15	2,00	41,0	260	77,4	2697	2,15	2,00	41,0	208	64,6	2814	2,15	2,00	41,0	174	55,8	2906	2,15	2,00	41,0
6,33	0,0188	276	90,7	2976	2,23	2,00	40,6	229	77,4	3065	2,23	2,00	40,6	183	64,6	3198	2,23	2,00	40,6	153	55,8	3303	2,23	2,00	40,6
7,25	0,0182	241	90,7	3409	2,30	2,00	41,0	200	77,4	3511	2,30	2,00	41,0	160	64,6	3663	2,30	2,00	41,0	134	55,8	3784	2,30	2,00	41,0
7,79	0,0172	225	90,7	3662	2,40	2,00	40,5	186	77,4	3771	2,40	2,00	40,5	149	64,6	3934	2,40	2,00	40,5	125	55,8	4064	2,40	2,00	40,5
8,39	0,0163	209	90,7	3944	2,48	2,00	41,1	173	77,4	4062	2,48	2,00	41,1	138	64,6	4238	2,48	2,00	41,1	116	55,8	4377	2,48	2,00	41,1
9,83	0,0156	178	90,7	4621	2,55	2,00	38,8	148	77,4	4759	2,55	2,00	38,8	118	64,6	4965	2,55	2,00	38,8	99	55,8	5129	2,55	2,00	38,8
10,70	0,0151	164	90,7	5032	2,63	2,00	38,8	135	77,4	5183	2,63	2,00	38,8	108	64,6	5407	2,63	2,00	38,8	91	55,5	5556	2,63	2,00	38,8
11,71	0,0142	149	90,7	5507	2,73	2,00	38,8	124	76,5	5606	2,73	2,00	38,8	99	62,0	5679	2,73	2,00	38,8	83	52,3	5729	2,73	2,00	38,8
12,89	0,0142	136	78,0	5212	2,80	2,00	38,6	113	65,4	5274	2,80	2,00	38,6	90	55,0	5544	2,80	2,00	38,6	75	45,0	5425	2,80	2,00	38,6
14,79	0,0139	118	49,9	3826	2,83	2,00	36,1	98	42,5	3932	2,83	2,00	36,1	78	35,2	4071	2,83	2,00	36,1	66	30,5	4219	2,83	2,00	36,1
16,10	0,0134	109	49,9	4166	2,88	2,00	36,1	90	42,5	4282	2,88	2,00	36,1	72	35,2	4433	2,88	2,00	36,1	60	30,5	4594	2,88	2,00	36,1
17,62	0,0131	99	49,9	4559	2,95	2,00	33,2	82	42,5	4686	2,95	2,00	33,2	66	35,2	4852	2,95	2,00	33,2	55	30,5	5027	2,95	2,00	33,2
19,39	0,0131	90	49,9	5017	3,00	2,00	33,2	75	42,5	5157	3,00	2,00	33,2	60	35,2	5339	3,00	2,00	33,2	50	30,0	5442	3,00	2,00	33,2
20,74	0,0125	84	30,8	3312	3,05	2,00	33,2	70	26,1	3387	3,05	2,00	33,2	56	22,0	3569	3,05	2,00	33,2	47	18,9	3666	3,05	2,00	33,2
22,59	0,0123	77	30,8	3606	3,13	2,00	32,9	64	26,1	3688	3,13	2,00	32,9	51	22,0	3886	3,13	2,00	32,9	43	18,9	3993	3,13	2,00	32,9
24,72	0,0076	71	30,8	3946	3,20	2,00	32,9	59	26,1	4036	3,20	2,00	32,9	47	22,0	4253	3,20	2,00	32,9	39	18,9	4369	3,20	2,00	32,9
27,20	0,0074	64	30,8	4343	3,28	2,00	32,9	53	26,1	4442	3,28	2,00	32,9	43	22,0	4680	3,28	2,00	32,9	36	18,9	4808	3,28	2,00	32,9

Potenze termiche / Thermal power / Thermische Grenzleistung PtN [kW]

(senza raffreddamento / Without cooling / ohne Kühlung)

82

RX01 812

Calculation of gear - Service Factor:
3.6-ISO; 3.8-DIN; 2.0 - AGMA

Calculation of bearings - hours min - ISO 281
Output axis: 100.000 - Others axis: 50.000



387

ir	J1 kgm ²	n ₁ = 1750 min ⁻¹					n ₁ = 1450 min ⁻¹					n ₁ = 1160 min ⁻¹					n ₁ = 970 min ⁻¹								
		n ₂ min ⁻¹	P kW	T _N Nm	Fr ₁ kN	Fr ₂ kN	Fa ₂ kN	n ₂ min ⁻¹	P kW	T _N Nm	Fr ₁ kN	Fr ₂ kN	Fa ₂ kN	n ₂ min ⁻¹	P kW	T _N Nm	Fr ₁ kN	Fr ₂ kN	Fa ₂ kN	n ₂ min ⁻¹	P kW	T _N Nm	Fr ₁ kN	Fr ₂ kN	Fa ₂ kN
4,48	0,0392	391	132,0	3063	2,55	2,00	46,4	324	110,0	3080	2,55	2,00	46,4	259	90,0	3150	2,55	2,00	46,4	217	75,0	3139	2,55	2,00	46,4
5,03	0,0372	348	132,0	3440	2,63	2,00	46,4	288	110,0	3460	2,63	2,00	46,4	231	90,0	3538	2,63	2,00	46,4	193	75,0	3526	2,63	2,00	46,4
5,67	0,0353	308	132,0	3883	2,73	2,00	46,4	256	110,0	3905	2,73	2,00	46,4	204	90,0	3994	2,73	2,00	46,4	171	75,0	3980	2,73	2,00	46,4
6,44	0,0335	272	132,0	4410	2,80	2,00	46,4	225	110,0	4435	2,80	2,00	46,4	180	90,0	4536	2,80	2,00	46,4	151	75,0	4521	2,80	2,00	46,4
6,89	0,0324	254	121,8	4349	2,90	2,00	47,5	211	110,0	4740	2,90	2,00	47,5	168	90,0	4848	2,90	2,00	47,5	141	75,0	4831	2,90	2,00	47,5
7,92	0,0306	221	121,8	5002	2,98	2,00	46,5	183	110,0	5452	2,98	2,00	46,5	146	90,0	5576	2,98	2,00	46,5	122	75,0	5557	2,98	2,00	46,5
8,53	0,0290	205	121,8	5386	3,08	2,00	45,7	170	110,0	5870	3,08	2,00	45,7	136	90,0	6004	3,08	2,00	45,7	114	75,0	5983	3,08	2,00	45,7
9,99	0,0277	175	121,8	6307	3,15	2,00	45,0	145	110,0	6875	3,15	2,00	45,0	116	90,0	7031	3,15	2,00	45,0	97	75,0	7007	3,15	2,00	45,0
10,88	0,0269	161	121,8	6867	3,25	2,00	44,4	133	110,0	7485	3,25	2,00	44,4	107	90,0	7655	3,25	2,00	44,4	89	75,0	7629	3,25	2,00	44,4
11,90	0,0253	147	121,0	7463	3,33	2,00	44,0	122	101,7	7571	3,33	2,00	44,0	98	90,0	8375	3,33	2,00	44,0	82	69,8	7767	3,33	2,00	44,0
13,09	0,2500	134	104,2	7071	3,43	2,00	41,6	111	90,0	7371	3,43	2,00	41,6	89	75,0	7679	3,43	2,00	41,6	74	60,5	7407	3,43	2,00	41,6
15,03	0,0247	116	61,4	4784	3,43	2,00	41,6	96	55,0	5172	3,43	2,00	41,6	77	45,0	5290	3,43	2,00	41,6	65	37,6	5286	3,43	2,00	41,6
16,36	0,0238	107	61,4	5209	3,50	2,00	41,6	89	55,0	5631	3,50	2,00	41,6	71	45,0	5759	3,50	2,00	41,6	59	37,6	5755	3,50	2,00	41,6
17,90	0,0233	98	61,4	5699	3,60	2,00	39,5	81	55,0	6161	3,60	2,00	39,5	65	45,0	6301	3,60	2,00	39,5	54	37,6	6296	3,60	2,00	39,5
19,70	0,0230	89	61,4	6270	3,68	2,00	39,5	74	55,0	6778	3,68	2,00	39,5	59	45,0	6932	3,68	2,00	39,5	49	37,6	6927	3,68	2,00	39,5
21,08	0,0222	83	42,0	4590	3,68	2,00	39,5	69	37,0	4880	3,68	2,00	39,5	55	30,0	4946	3,68	2,00	39,5	46	25,4	5008	3,68	2,00	39,5
22,95	0,0219	76	42,0	4997	3,78	2,00	38,3	63	37,0	5313	3,78	2,00	38,3	51	30,0	5385	3,78	2,00	38,3	42	25,4	5452	3,78	2,00	38,3
25,11	0,0135	70	42,0	5467	3,85	2,00	38,3	58	37,0	5813	3,85	2,00	38,3	46	30,0	5891	3,85	2,00	38,3	39	25,4	5965	3,85	2,00	38,3

Potenze termiche / Thermal power / Thermische Grenzleistung PtN [kW]

(senza raffreddamento / Without cooling / ohne Kühlung)

104

1.9 Prestazioni riduttori

1.9 Gear unit ratings

1.9 Leistungen der Getriebe

RX01 814

Calculation of gear - Service Factor:
3.6-ISO; 3.8-DIN; 2.0 - AGMA

Calculation of bearings - hours min - ISO 281
Output axis: 100.000 - Others axis: 50.000



561



ir	J1 kgm ²	n ₁ = 1750 min ⁻¹						n ₁ = 1450 min ⁻¹						n ₁ = 1160 min ⁻¹						n ₁ = 970 min ⁻¹					
		n ₂ min ⁻¹	P kW	T _N Nm	Fr ₁ kN	Fr ₂ kN	Fa ₂ kN	n ₂ min ⁻¹	P kW	T _N Nm	Fr ₁ kN	Fr ₂ kN	Fa ₂ kN	n ₂ min ⁻¹	P kW	T _N Nm	Fr ₁ kN	Fr ₂ kN	Fa ₂ kN	n ₂ min ⁻¹	P kW	T _N Nm	Fr ₁ kN	Fr ₂ kN	Fa ₂ kN
4,40	0,0694	398	187,8	4331	2,58	2,00	43,0	329	160,0	4453	2,58	2,00	43,0	264	132,0	4592	2,58	2,00	43,0	220	111,7	4647	2,58	2,00	43,0
4,93	0,0660	355	187,8	4847	2,75	2,00	43,0	294	160,0	4984	2,75	2,00	43,0	235	132,0	5139	2,75	2,00	43,0	197	111,7	5201	2,75	2,00	43,0
5,54	0,0627	316	187,8	5449	2,90	2,00	43,0	262	160,0	5603	2,90	2,00	43,0	209	132,0	5778	2,90	2,00	43,0	175	111,7	5847	2,90	2,00	43,0
6,26	0,0596	279	187,8	6160	3,05	2,00	42,6	232	160,0	6334	3,05	2,00	42,6	185	132,0	6532	3,05	2,00	42,6	155	111,7	6610	3,05	2,00	42,6
7,13	0,0576	245	184,3	6883	3,20	2,00	34,1	203	160,0	7212	3,20	2,00	34,1	163	132,0	7438	3,20	2,00	34,1	136	111,7	7527	3,20	2,00	34,1
7,63	0,0544	229	184,3	7368	3,38	2,00	34,1	190	160,0	7720	3,38	2,00	34,1	152	132,0	7962	3,38	2,00	34,1	127	111,7	8057	3,38	2,00	34,1
8,81	0,0516	199	184,3	8510	3,53	1,50	34,1	165	160,0	8916	3,53	1,50	34,1	132	132,0	9195	3,53	1,50	34,1	110	111,7	9305	3,53	1,50	34,1
9,52	0,0493	184	184,3	9188	3,53	1,00	31,8	152	160,0	9626	3,53	1,00	31,8	122	132,0	9927	3,53	1,00	31,8	102	111,7	10046	3,53	1,00	31,8
11,22	0,0478	156	181,4	10663	3,83	2,00	27,2	129	151,8	10769	3,83	2,00	27,2	103	122,5	10863	3,83	2,00	27,2	86	103,1	10934	3,83	2,00	27,2
12,27	0,0478	143	165,7	10651	4,00	2,00	27,2	118	136,7	10605	4,00	2,00	27,2	95	111,8	10841	4,00	2,00	27,2	79	94,0	10901	4,00	2,00	27,2
13,49	0,0449	130	133,8	9458	4,00	2,00	27,2	107	112,6	9606	4,00	2,00	27,2	86	91,7	9779	4,00	2,00	27,2	72	77,7	9909	4,00	2,00	27,2
14,20	0,0440	123	144,8	10772	4,15	2,00	25,9	102	120,7	10837	4,15	2,00	25,9	82	97,8	10976	4,15	2,00	25,9	68	81,8	10979	4,15	2,00	25,9
15,52	0,0430	113	132,7	10789	4,15	2,00	25,9	93	110,0	10794	4,15	2,00	25,9	75	90,0	11040	4,15	2,00	25,9	63	75,0	11002	4,15	2,00	25,9
16,88	0,0424	104	100,8	8916	4,30	2,00	25,9	86	90,0	9607	4,30	2,00	25,9	69	75,0	10008	4,30	2,00	25,9	57	61,0	9734	4,30	2,00	25,9
17,07	0,0420	103	110,0	9837	4,30	2,00	25,9	85	91,1	9832	4,30	2,00	25,9	68	75,0	10118	4,30	2,00	25,9	57	62,5	10084	4,30	2,00	25,9
18,46	0,0414	95	100,8	9749	4,70	2,00	25,1	79	90,0	10506	4,70	2,00	25,1	63	75,0	10943	4,70	2,00	25,1	53	61,0	10644	4,70	2,00	25,1
20,30	0,0395	86	92,5	9839	4,63	2,00	25,1	71	77,4	9936	4,63	2,00	25,1	57	63,2	10141	4,63	2,00	25,1	48	55,0	10554	4,63	2,00	25,1
23,68	0,0389	74	60,5	7505	4,78	2,00	26,4	61	51,0	7635	4,78	2,00	26,4	49	42,5	7954	4,78	2,00	26,4	41	37,0	8281	4,78	2,00	26,4
25,89	0,0240	68	60,5	8207	4,93	2,00	26,4	56	51,0	8349	4,93	2,00	26,4	45	42,5	8697	4,93	2,00	26,4	37	37,0	9055	4,93	2,00	26,4
28,48	0,0234	61	60,5	9025	5,08	2,00	26,4	51	51,0	9182	5,08	2,00	26,4	41	42,5	9565	5,08	2,00	26,4	34	37,0	9958	5,08	2,00	26,4

Potenze termiche / Thermal power / Thermische Grenzleistung PtN [kW]

(senza raffreddamento / Without cooling / ohne Kühlung)

127

RX01 816

Calculation of gear - Service Factor:
3.6-ISO; 3.8-DIN; 2.0 - AGMA

Calculation of bearings - hours min - ISO 281
Output axis: 100.000 - Others axis: 50.000



782

ir	J1 kgm ²	n ₁ = 1750 min ⁻¹						n ₁ = 1450 min ⁻¹						n ₁ = 1160 min ⁻¹						n ₁ = 970 min ⁻¹					
		n ₂ min ⁻¹	P kW	T _N Nm	Fr ₁ kN	Fr ₂ kN	Fa ₂ kN	n ₂ min ⁻¹	P kW	T _N Nm	Fr ₁ kN	Fr ₂ kN	Fa ₂ kN	n ₂ min ⁻¹	P kW	T _N Nm	Fr ₁ kN	Fr ₂ kN	Fa ₂ kN	n ₂ min ⁻¹	P kW	T _N Nm	Fr ₁ kN	Fr ₂ kN	Fa ₂ kN
4,39	0,1237	399	264,4	6075	2,75	2,00	63,8	331	225,0	6239	2,75	2,00	63,8	264	178,0	6170	2,75	2,00	63,8	221	149,7	6205	2,75	2,00	63,8
4,93	0,1175	355	264,4	6829	2,93	2,00	63,8	294	225,0	7014	2,93	2,00	63,8	235	178,0	6936	2,93	2,00	63,8	197	149,7	6975	2,93	2,00	63,8
5,57	0,1116	314	264,4	7714	3,13	2,00	63,8	260	225,0	7922	3,13	2,00	63,8	208	178,0	7834	3,13	2,00	63,8	174	149,7	7879	3,13	2,00	63,8
5,93	0,1060	295	264,4	8216	3,30	2,00	63,2	244	225,0	8439	3,30	2,00	63,2	196	178,0	8345	3,30	2,00	63,2	164	149,7	8393	3,30	2,00	63,2
6,77	0,1024	259	250,0	8862	3,50	2,00	63,2	214	203,6	8711	3,50	2,00	63,2	171	166,2	8888	3,50	2,00	63,2	143	143,4	9171	3,50	2,00	63,2
7,79	0,0967	225	232,0	9464	3,68	2,00	61,3	186	200,0	9847	3,68	2,00	61,3	149	166,2	10229	3,68	2,00	61,3	125	143,4	10554	3,68	2,00	61,3
9,06	0,0917	193	232,0	11015	3,88	2,00	59,7	160	200,0	11460	3,88	2,00	59,7	128	166,2	11904	3,88	2,00	59,7	107	143,4	12283	3,88	2,00	59,7
9,83	0,0877	178	232,0	11945	4,05	2,00	49,0	148	200,0	12428	4,05	2,00	49,0	118	166,2	12909	4,05	2,00	49,0	99	143,4	13320	4,05	2,00	49,0
10,70	0,0849	164	232,0	13008	4,25	2,00	49,0	135	200,0	13534	4,25	2,00	49,0	108	166,2	14058	4,25	2,00	49,0	91	143,4	14505	4,25	2,00	49,0
11,71	0,0799	149	232,0	14234	4,43	2,00	49,0	124	200,0	14810	4,43	2,00	49,0	99	166,2	15384	4,43	2,00	49,0	83	140,2	15519	4,43	2,00	49,0
12,89	0,0799	136	209,0	14112	4,63	2,00	49,0	113	175,7	14318	4,63	2,00	49,0	90	142,5	14516	4,63	2,00	49,0	75	120,6	14691	4,63	2,00	49,0
13,55	0,0782	129	200,0	14193	4,63	2,00	49,0	107	162,5	13918	4,63	2,00	49,0	86	132,4	14175	4,63	2,00	49,0	72	111,7	14301	4,63	2,00	49,0
14,82	0,0782	118	200,0	15532	4,80	1,00	47,9	98	162,5	15230	4,80	1,00	47,9	78	132,4	15512	4,80	1,00	47,9	65	111,7	15650	4,80	1,00	47,9
16,31	0,0754	107	168,7	14418	4,80	1,00	50,0	89	141,2	14564	4,80	1,00	50,0	71	113,0	14570	4,80	1,00	50,0	59	97,0	14956	4,80	1,00	50,0
17,62	0,0737	99	132,0	12186	5,00	2,00	50,7	82	110,0	12256	5,00	2,00	50,7	66	91,1	12688	5,00	2,00	50,7	55	79,0	13158	5,00	2,00	50,7
18,07	0,0737	97	141,2	13370	5,00	2,00	50,7	80	117,7	13451	5,00	2,00	50,7	64	94,8	13543	5,00	2,00	50,7	54	81,1	13855	5,00	2,00	50,7
19,39	0,0737	90	132,0	13411	5,18	2,00	50,7	75	110,0	13489	5,18	2,00	50,7	60	91,1	13964	5,18	2,00	50,7	50	79,0	14481	5,18	2,00	50,7

Potenze termiche / Thermal power / Thermische Grenzleistung PtN [kW]

(senza raffreddamento / Without cooling / ohne Kühlung)

158

1.9 Prestazioni riduttori

1.9 Gear unit ratings

1.9 Leistungen der Getriebe

RXO2 814

Calculation of gear - Service Factor:
3.6-ISO; 3.8-DIN; 2.0 - AGMA

Calculation of bearings - hours min - ISO 281
Output axis: 100.000 - Others axis: 50.000



659

ir	J1 kgm ²	n ₁ = 1750 min ⁻¹						n ₁ = 1450 min ⁻¹						n ₁ = 1160 min ⁻¹						n ₁ = 970 min ⁻¹					
		n ₂ min ⁻¹	P kW	T _N Nm	Fr ₁ kN	Fr ₂ kN	Fa ₂ kN	n ₂ min ⁻¹	P kW	T _N Nm	Fr ₁ kN	Fr ₂ kN	Fa ₂ kN	n ₂ min ⁻¹	P kW	T _N Nm	Fr ₁ kN	Fr ₂ kN	Fa ₂ kN	n ₂ min ⁻¹	P kW	T _N Nm	Fr ₁ kN	Fr ₂ kN	Fa ₂ kN
19,4	0,0479	90	91,0	9056	4,63	2,00	25,1	75	76,7	9212	4,63	2,00	25,1	60	64,7	9714	4,63	2,00	25,1	50	55,9	10036	4,63	2,00	25,1
21,9	0,0447	80	91,0	10223	4,63	2,00	25,1	66	76,7	10399	4,63	2,00	25,1	53	64,7	10965	4,63	2,00	25,1	44	55,9	11330	4,63	2,00	25,1
24,9	0,0417	70	91,0	11623	4,78	2,00	26,4	58	76,7	11824	4,78	2,00	26,4	47	64,7	12467	4,78	2,00	26,4	39	55,9	12882	4,78	2,00	26,4
28,5	0,0389	61	91,0	13304	5,08	2,00	26,4	51	76,7	13533	5,08	2,00	26,4	41	64,7	14270	5,08	2,00	26,4	34	55,9	14744	5,08	2,00	26,4
30,6	0,0363	57	91,0	14284	5,08	2,00	26,4	47	76,7	14530	5,08	2,00	26,4	38	64,7	15321	5,08	2,00	26,4	32	55,9	15830	5,08	2,00	26,4
32,9	0,0339	53	91,0	15358	5,08	2,00	26,4	44	76,7	15623	5,08	2,00	26,4	35	64,7	16473	5,08	2,00	26,4	29	55	16746	5,08	2,00	26,4
38,6	0,0316	45	90,0	17821	5,08	2,00	26,4	38	70,5	16848	5,08	2,00	26,4	30	55,0	16429	5,08	2,00	26,4	25	45,3	16182	5,08	2,00	26,4

Potenze termiche / Thermal power / Thermische Grenzleistung PtN [kW]
(senza raffreddamento / Without cooling / ohne Kühlung)

102

RXO1 818

Calculation of gear - Service Factor:
3.6-ISO; 3.8-DIN; 2.0 - AGMA

Calculation of bearings - hours min - ISO 281
Output axis: 100.000 - Others axis: 50.000



1090

ir	J1 kgm ²	n ₁ = 1750 min ⁻¹						n ₁ = 1450 min ⁻¹						n ₁ = 1160 min ⁻¹						n ₁ = 970 min ⁻¹					
		n ₂ min ⁻¹	P kW	T _N Nm	Fr ₁ kN	Fr ₂ kN	Fa ₂ kN	n ₂ min ⁻¹	P kW	T _N Nm	Fr ₁ kN	Fr ₂ kN	Fa ₂ kN	n ₂ min ⁻¹	P kW	T _N Nm	Fr ₁ kN	Fr ₂ kN	Fa ₂ kN	n ₂ min ⁻¹	P kW	T _N Nm	Fr ₁ kN	Fr ₂ kN	Fa ₂ kN
4,39	0,2200	399	356,8	8198	4,75	3,00	55,1	331	298,0	8264	4,75	3,00	55,1	264	250,0	8666	4,75	3,00	55,1	221	202,1	8378	4,75	3,00	55,1
4,93	0,2090	355	356,8	9215	4,93	3,00	55,1	294	298,0	9289	4,93	3,00	55,1	235	250,0	9741	4,93	3,00	55,1	197	202,1	9417	4,93	3,00	55,1
5,57	0,1985	314	356,8	10409	5,13	3,00	55,1	260	298,0	10493	5,13	3,00	55,1	208	250,0	11003	5,13	3,00	55,1	174	202,1	10637	5,13	3,00	55,1
6,33	0,1885	276	356,8	11831	5,33	3,00	57,3	229	298,0	11926	5,33	3,00	57,3	183	250,0	12506	5,33	3,00	57,3	153	202,1	12090	5,33	3,00	57,3
6,77	0,1820	259	356,8	12648	5,53	3,00	57,3	214	298,0	12750	5,53	3,00	57,3	171	250,0	13370	5,53	3,00	57,3	143	202,1	12925	5,53	3,00	57,3
7,25	0,1720	241	355,0	13484	5,73	3,00	59,9	200	284,0	13019	5,73	3,00	59,9	160	229,6	13156	5,73	3,00	59,9	134	200,0	13705	5,73	3,00	59,9
8,39	0,1630	209	324,3	14250	5,93	3,00	59,9	173	280,0	14849	5,93	3,00	59,9	138	229,6	15220	5,93	3,00	59,9	116	200,0	15855	5,93	3,00	59,9
9,06	0,1630	193	324,3	15397	5,93	3,00	59,9	160	280,0	16044	5,93	3,00	59,9	128	229,6	16445	5,93	3,00	59,9	107	200,0	17131	5,93	3,00	59,9
9,83	0,1560	178	324,3	16697	6,13	3,00	64,6	148	280,0	17399	6,13	3,00	64,6	118	229,6	17834	6,13	3,00	64,6	99	200,0	18578	6,13	3,00	64,6
10,70	0,1510	164	324,3	18183	6,33	3,00	65,8	135	280,0	18947	6,33	3,00	65,8	108	229,6	19421	6,33	3,00	65,8	91	200,0	20231	6,33	3,00	65,8
11,71	0,1510	149	324,3	19897	6,50	3,00	65,9	124	280,0	20734	6,50	3,00	65,9	99	229,6	21252	6,50	3,00	65,9	83	200,0	22138	6,50	3,00	65,9
12,89	0,1420	136	315,0	21270	6,53	3,00	65,4	113	254,3	20724	6,53	3,00	65,4	90	206,5	21035	6,53	3,00	65,4	75	174,6	21270	6,53	3,00	65,4
13,55	0,1400	129	264,4	18764	6,53	3,00	60,6	107	225,8	19340	6,53	3,00	60,6	86	187,0	20021	6,53	3,00	60,6	72	160,5	20549	6,53	3,00	60,6
14,82	0,1390	118	264,4	20533	6,73	3,00	60,6	98	225,8	21163	6,73	3,00	60,6	78	187,0	21908	6,73	3,00	60,6	65	160,5	22487	6,73	3,00	60,6
16,31	0,1340	107	250,0	21366	6,93	3,00	60,6	89	204,5	21094	6,93	3,00	60,6	71	165,8	21377	6,93	3,00	60,6	59	140,2	21617	6,93	3,00	60,6
17,62	0,1310	99	179,0	16525	7,13	3,00	59,4	82	160,0	17828	7,13	3,00	59,4	66	132,0	18385	7,13	3,00	59,4	55	110,0	18321	7,13	3,00	59,4
18,07	0,1310	97	207,0	19601	7,13	3,00	59,4	80	173,9	19874	7,13	3,00	59,4	64	140,9	20128	7,13	3,00	59,4	54	119,0	20329	7,13	3,00	59,4
19,39	0,1249	90	179,0	18187	7,33	3,00	59,4	75	160,0	19620	7,33	3,00	59,4	60	140,9	21597	7,33	3,00	59,4	50	110,0	20163	7,33	3,00	59,4

Potenze termiche / Thermal power / Thermische Grenzleistung PtN [kW]
(senza raffreddamento / Without cooling / ohne Kühlung)

203

RXO2 816

Calculation of gear - Service Factor:
3.6-ISO; 3.8-DIN; 2.0 - AGMA

Calculation of bearings - hours min - ISO 281
Output axis: 100.000 - Others axis: 50.000



917

ir	J1 kgm ²	n ₁ = 1750 min ⁻¹						n ₁ = 1450 min ⁻¹						n ₁ = 1160 min ⁻¹						n ₁ = 970 min ⁻¹					
		n ₂ min ⁻¹	P kW	T _N Nm	Fr ₁ kN	Fr ₂ kN	Fa ₂ kN	n ₂ min ⁻¹	P kW	T _N Nm	Fr ₁ kN	Fr ₂ kN	Fa ₂ kN	n ₂ min ⁻¹	P kW	T _N Nm	Fr ₁ kN	Fr ₂ kN	Fa ₂ kN	n ₂ min ⁻¹	P kW	T _N Nm	Fr ₁ kN	Fr ₂ kN	Fa ₂ kN
19,39	0,0850	90	123	12234	5,18	2,00	50,7	75	110	13205	5,18	2,00	50,7	60	90,0	13505	5,18	2,00	50,7	50	75,5	13548	5,18	2,00	50,7
21,89	0,0793	80	123	13812	5,18	2,00	50,7	66	110	14907	5,18	2,00	50,7	53	90,0	15246	5,18	2,00	50,7	44	75,5	15295	5,18	2,00	50,7
24,86	0,0740	70	123	15686	5,55	2,00	51,2	58	110	16930	5,55	2,00	51,2	47	90,0	17315	5,55	2,00	51,2	39	75,5	17370	5,55	2,00	51,2
26,57	0,0691	66	123	16764	5,55	2,00	51,2	55	110	18095	5,55	2,00	51,2	44	90,0	18506	5,55	2,00	51,2	37	75,5	18565	5,55	2,00	51,2
30,55	0,0645	57	123	19276	5,75	2,00	51,2	47	110	20805	5,75	2,00	51,2	38	90,0	21278	5,75	2,00	51,2	32	75,5	21346	5,75	2,00	51,2
32,9	0,0602	53	123	20758	5,75	2,00	51,2	44	110	22405	5,75	2,00	51,2	35	90,0	22915	5,75	2,00	51,2	29	75,0	22836	5,75	2,00	51,2
38,53	0,0562	45	120	23718	5,75	2,00	51,2	38	96,9	23115	5,75	2,00	51,2	30	75,3	22453	5,75	2,00	51,2	25	61,9	22072	5,75	2,00	51,2

Potenze termiche / Thermal power / Thermische Grenzleistung PtN [kW]
(senza raffreddamento / Without cooling / ohne Kühlung)

127

1.9 Prestazioni riduttori

1.9 Gear unit ratings

1.9 Leistungen der Getriebe

RX01 820

Calculation of gear - Service Factor:
3.6-ISO; 3.8-DIN; 2.0 - AGMA

Calculation of bearings - hours min - ISO 281
Output axis: 100.000 - Others axis: 50.000



1522



ir	J1 kgm ²	n ₁ = 1750 min ⁻¹						n ₁ = 1450 min ⁻¹						n ₁ = 1160 min ⁻¹						n ₁ = 970 min ⁻¹					
		n ₂ min ⁻¹	P kW	T _N Nm	Fr ₁ kN	Fr ₂ kN	Fa ₂ kN	n ₂ min ⁻¹	P kW	T _N Nm	Fr ₁ kN	Fr ₂ kN	Fa ₂ kN	n ₂ min ⁻¹	P kW	T _N Nm	Fr ₁ kN	Fr ₂ kN	Fa ₂ kN	n ₂ min ⁻¹	P kW	T _N Nm	Fr ₁ kN	Fr ₂ kN	Fa ₂ kN
4,47	0,3912	392	450,0	10531	7,00	3,00	67,2	325	371,1	10482	7,00	3,00	67,2	260	315,0	11122	7,00	3,00	67,2	217	252,4	10657	7,00	3,00	67,2
5,02	0,3715	348	450,0	11838	7,23	3,00	70,1	289	371,1	11782	7,23	3,00	70,1	231	315,0	12502	7,23	3,00	70,1	193	252,4	11979	7,23	3,00	70,1
5,67	0,3529	309	450,0	13372	7,43	3,00	70,6	256	371,1	13309	7,43	3,00	70,6	205	315,0	14122	7,43	3,00	70,6	171	252,4	13532	7,43	3,00	70,6
6,45	0,3352	271	450,0	15198	7,63	3,00	74,1	225	371,1	15127	7,63	3,00	74,1	180	315,0	16050	7,63	3,00	74,1	150	252,4	15380	7,63	3,00	74,1
7,38	0,3237	237	450,0	17409	7,83	3,00	74,1	196	371,1	17327	7,83	3,00	74,1	157	315,0	18385	7,83	3,00	74,1	131	252,4	17617	7,83	3,00	74,1
7,93	0,3058	221	420,5	17473	8,05	3,00	74,1	183	355,0	17803	8,05	3,00	74,1	146	290,0	18179	8,05	3,00	74,1	122	250,4	18772	8,05	3,00	74,1
9,23	0,2899	190	404,0	19537	8,25	3,00	79,0	157	355,0	20719	8,25	3,00	79,0	126	290,0	21157	8,25	3,00	79,0	105	250,4	21846	8,25	3,00	79,0
10,01	0,2774	175	404,0	21187	8,45	3,00	79,3	145	355,0	22469	8,45	3,00	79,3	116	290,0	22944	8,45	3,00	79,3	97	250,4	23691	8,45	3,00	79,3
10,90	0,2685	161	404,0	23072	8,65	3,00	79,3	133	355,0	24468	8,65	3,00	79,3	106	290,0	24985	8,65	3,00	79,3	89	250,4	25799	8,65	3,00	79,3
11,93	0,2525	147	404,0	25248	8,88	3,00	82,4	122	355,0	26776	8,88	3,00	82,4	97	290,0	27341	8,88	3,00	82,4	81	250,4	28232	8,88	3,00	82,4
13,13	0,2472	133	404,0	27786	9,08	3,00	82,4	110	355,0	29467	9,08	3,00	82,4	88	282,7	29332	9,08	3,00	82,4	74	250,0	31020	9,08	3,00	82,4
13,55	0,2450	129	328,0	23284	9,08	3,00	78,3	107	282,2	24177	9,08	3,00	78,3	86	235,0	25167	9,08	3,00	78,3	72	203,1	26011	9,08	3,00	78,3
14,82	0,2400	118	328,0	25466	9,08	3,00	78,3	98	282,2	26443	9,08	3,00	78,3	78	235,0	27525	9,08	3,00	78,3	65	203,1	28449	9,08	3,00	78,3
16,31	0,2383	107	328,0	28026	9,28	3,00	78,3	89	282,2	29102	9,28	3,00	78,3	71	231,4	29829	9,28	3,00	78,3	59	200,0	30831	9,28	3,00	78,3
17,62	0,2330	99	225,0	20772	9,48	3,00	78,3	82	200,0	22284	9,48	3,00	78,3	66	160,0	22284	9,48	3,00	78,3	55	137,1	22835	9,48	3,00	78,3
18,07	0,2300	97	288,6	27321	9,48	3,00	78,3	80	250,0	28563	9,48	3,00	78,3	64	200,0	28563	9,48	3,00	78,3	54	168,5	28778	9,48	3,00	78,3
19,39	0,2221	90	225,0	22860	9,70	3,00	78,3	75	200,0	24525	9,70	3,00	78,3	60	160,0	24525	9,70	3,00	78,3	50	137,1	25131	9,70	3,00	78,3

Potenze termiche / Thermal power / Thermische Grenzleistung PtN [kW]

(senza raffreddamento / Without cooling / ohne Kühlung)

252

RX02 818

Calculation of gear - Service Factor:
3.6-ISO; 3.8-DIN; 2.0 - AGMA

Calculation of bearings - hours min - ISO 281
Output axis: 100.000 - Others axis: 50.000



1281

ir	J1 kgm ²	n ₁ = 1750 min ⁻¹						n ₁ = 1450 min ⁻¹						n ₁ = 1160 min ⁻¹						n ₁ = 970 min ⁻¹					
		n ₂ min ⁻¹	P kW	T _N Nm	Fr ₁ kN	Fr ₂ kN	Fa ₂ kN	n ₂ min ⁻¹	P kW	T _N Nm	Fr ₁ kN	Fr ₂ kN	Fa ₂ kN	n ₂ min ⁻¹	P kW	T _N Nm	Fr ₁ kN	Fr ₂ kN	Fa ₂ kN	n ₂ min ⁻¹	P kW	T _N Nm	Fr ₁ kN	Fr ₂ kN	Fa ₂ kN
19,35	0,1512	90	184,7	18333	7,33	3,00	59,4	75	160,0	19167	7,33	3,00	59,4	60	132,0	19766	7,33	3,00	59,4	50	112,0	20057	7,33	3,00	59,4
21,76	0,1411	80	184,7	20617	7,53	3,00	59,4	67	160,0	21555	7,53	3,00	59,4	53	132,0	22228	7,53	3,00	59,4	45	112,0	22555	7,53	3,00	59,4
24,6	0,1317	71	184,7	23307	7,73	3,00	56,4	59	160,0	24368	7,73	3,00	56,4	47	132,0	25129	7,73	3,00	56,4	39	112,0	25498	7,73	3,00	56,4
28,01	0,1229	62	184,7	26538	7,93	3,00	56,4	52	160,0	27746	7,93	3,00	56,4	41	132,0	28613	7,93	3,00	56,4	35	112,0	29033	7,93	3,00	56,4
29,98	0,1147	58	184,7	28405	7,93	3,00	56,4	48	160,0	29697	7,93	3,00	56,4	39	132,0	30625	7,93	3,00	56,4	32	112,0	31075	7,93	3,00	56,4
34,63	0,1071	51	184,7	32810	7,93	3,00	56,4	42	160,0	34303	7,93	3,00	56,4	33	132,0	35375	7,93	3,00	56,4	28	110,9	35542	7,93	3,00	56,4
37,38	0,1000	47	184,7	35416	7,93	3,00	56,4	39	160,0	37027	7,93	3,00	56,4	31	124,5	36015	7,93	3,00	56,4	26	102,3	35389	7,93	3,00	56,4

Potenze termiche / Thermal power / Thermische Grenzleistung PtN [kW]

(senza raffreddamento / Without cooling / ohne Kühlung)

165

1.9 Prestazioni riduttori

1.9 Gear unit ratings

1.9 Leistungen der Getriebe

RX01 822

Calculation of gear - Service Factor:
3.6-ISO; 3.8-DIN; 2.0 - AGMA

Calculation of bearings - hours min - ISO 281
Output axis: 100.000 - Others axis: 50.000



2126

ir	J1 kgm ²	n ₁ = 1750 min ⁻¹						n ₁ = 1450 min ⁻¹						n ₁ = 1160 min ⁻¹						n ₁ = 970 min ⁻¹					
		n ₂ min ⁻¹	P kW	T _N Nm	Fr ₁ kN	Fr ₂ kN	Fa ₂ kN	n ₂ min ⁻¹	P kW	T _N Nm	Fr ₁ kN	Fr ₂ kN	Fa ₂ kN	n ₂ min ⁻¹	P kW	T _N Nm	Fr ₁ kN	Fr ₂ kN	Fa ₂ kN	n ₂ min ⁻¹	P kW	T _N Nm	Fr ₁ kN	Fr ₂ kN	Fa ₂ kN
4,41	0,6959	397	719,2	16606	9,35	3,00	44,4	329	630,0	17556	9,35	3,00	44,4	263	500,0	17417	9,35	3,00	44,4	220	426,4	17762	9,35	3,00	44,4
4,95	0,6609	353	719,2	18667	8,93	3,00	44,4	293	630,0	19735	8,93	3,00	44,4	234	500,0	19578	8,93	3,00	44,4	196	426,4	19966	8,93	3,00	44,4
5,60	0,6276	313	719,2	21086	9,20	3,00	44,4	259	630,0	22292	9,20	3,00	44,4	207	500,0	22115	9,20	3,00	44,4	173	426,4	22554	9,20	3,00	44,4
6,36	0,5960	275	719,2	23965	9,45	3,00	43,0	228	630,0	25336	9,45	3,00	43,0	182	500,0	25135	9,45	3,00	43,0	153	426,4	25634	9,45	3,00	43,0
7,29	0,5755	240	719,2	27451	9,73	3,00	40,0	199	589,0	27133	9,73	3,00	40,0	159	500,0	28791	9,73	3,00	40,0	133	426,4	29362	9,73	3,00	40,0
7,83	0,5439	224	710,0	29107	9,75	3,00	40,0	185	589,0	29143	9,75	3,00	40,0	148	500,0	30924	9,75	3,00	40,0	124	426,4	31537	9,75	3,00	40,0
9,11	0,5155	192	710,0	33875	10,25	3,00	30,0	159	589,0	33916	10,25	3,00	30,0	127	500,0	35989	10,25	3,00	30,0	107	426,4	36703	10,25	3,00	30,0
9,88	0,4933	177	710,0	36735	10,50	3,00	30,0	147	589,0	36780	10,50	3,00	30,0	117	500,0	39028	10,50	3,00	30,0	98	426,4	39802	10,50	3,00	30,0
10,76	0,4775	163	710,0	40005	10,78	3,00	30,0	135	589,0	40053	10,78	3,00	30,0	108	500,0	42501	10,78	3,00	30,0	90	426,4	43345	10,78	3,00	30,0
11,77	0,4775	149	710,0	43777	10,88	3,00	30,0	123	569,2	42356	10,88	3,00	30,0	99	461,5	42928	10,88	3,00	30,0	82	400,0	44495	10,88	3,00	30,0
12,95	0,4490	135	630,0	42749	11,03	3,00	30,0	112	514,8	42159	11,03	3,00	30,0	90	419,0	42892	11,03	3,00	30,0	75	355,2	43484	11,03	3,00	30,0
14,57	0,4396	120	400,0	30537	11,30	3,00	41,8	100	333,0	30682	11,30	3,00	41,8	80	280,0	32248	11,30	3,00	41,8	67	250,0	34433	11,30	3,00	41,8
15,87	0,4238	110	400,0	33254	11,55	3,00	38,5	91	333,0	33412	11,55	3,00	38,5	73	280,0	35118	11,55	3,00	38,5	61	250,0	37497	11,55	3,00	38,5
17,37	0,4143	101	400,0	36390	11,83	3,00	34,8	83	333,0	36562	11,83	3,00	34,8	67	280,0	38429	11,83	3,00	34,8	56	250,0	41032	11,83	3,00	34,8
19,11	0,3950	92	400,0	40048	12,08	3,00	30,6	76	333,0	40238	12,08	3,00	30,6	61	280,0	42292	12,08	3,00	30,6	51	250,0	45157	12,08	3,00	30,6

Potenze termiche / Thermal power / Thermische Grenzleistung PtN [kW]

(senza raffreddamento / Without cooling / ohne Kühlung)

304

RX02 820

Calculation of gear - Service Factor:
3.6-ISO; 3.8-DIN; 2.0 - AGMA

Calculation of bearings - hours min - ISO 281
Output axis: 100.000 - Others axis: 50.000



1789

ir	J1 kgm ²	n ₁ = 1750 min ⁻¹						n ₁ = 1450 min ⁻¹						n ₁ = 1160 min ⁻¹						n ₁ = 970 min ⁻¹					
		n ₂ min ⁻¹	P kW	T _N Nm	Fr ₁ kN	Fr ₂ kN	Fa ₂ kN	n ₂ min ⁻¹	P kW	T _N Nm	Fr ₁ kN	Fr ₂ kN	Fa ₂ kN	n ₂ min ⁻¹	P kW	T _N Nm	Fr ₁ kN	Fr ₂ kN	Fa ₂ kN	n ₂ min ⁻¹	P kW	T _N Nm	Fr ₁ kN	Fr ₂ kN	Fa ₂ kN
19,72	0,2600	89	232,7	23539	9,7	3,00	78,3	74	200,0	24417	9,7	3,00	78,3	59	166,3	25379	9,7	3,00	78,3	49	143,5	26189	9,7	3,00	78,3
22,28	0,2510	79	232,7	26595	10,1	3,00	74,4	65	200,0	27587	10,1	3,00	74,4	52	166,3	28673	10,1	3,00	74,4	44	143,5	29589	10,1	3,00	74,4
23,73	0,2342	74	232,7	28326	10,3	3,00	74,4	61	200,0	29383	10,3	3,00	74,4	49	166,3	30540	10,3	3,00	74,4	41	143,5	31514	10,3	3,00	74,4
27,07	0,2186	65	232,7	32313	10,3	3,00	74,4	54	200,0	33518	10,3	3,00	74,4	43	166,3	34838	10,3	3,00	74,4	36	143,5	35950	10,3	3,00	74,4
31,15	0,2040	56	232,7	37183	10,3	3,00	74,4	47	200,0	38570	10,3	3,00	74,4	37	166,3	40089	10,3	3,00	74,4	31	143,5	41368	10,3	3,00	74,4
36,25	0,1904	48	232,7	43271	10,3	3,00	74,4	40	200,0	44885	10,3	3,00	74,4	32	166,3	46652	10,3	3,00	74,4	27	143,5	48141	10,3	3,00	74,4
39,31	0,1777	45	232,7	46924	10,3	3,00	74,4	37	200,0	48674	10,3	3,00	74,4	30	163,8	49830	10,3	3,00	74,4	25	137,6	50059	10,3	3,00	74,4

Potenze termiche / Thermal power / Thermische Grenzleistung PtN [kW]

(senza raffreddamento / Without cooling / ohne Kühlung)

205

1.9 Prestazioni riduttori

1.9 Gear unit ratings

1.9 Leistungen der Getriebe

RX01 824

Calculation of gear - Service Factor:
3.6-ISO; 3.8-DIN; 2.0 - AGMA

Calculation of bearings - hours min - ISO 281
Output axis: 100.000 - Others axis: 50.000



2971



ir	J1 kgm ²	n ₁ = 1750 min ⁻¹						n ₁ = 1450 min ⁻¹						n ₁ = 1160 min ⁻¹						n ₁ = 970 min ⁻¹					
		n ₂ min ⁻¹	P kW	T _N Nm	Fr ₁ kN	Fr ₂ kN	Fa ₂ kN	n ₂ min ⁻¹	P kW	T _N Nm	Fr ₁ kN	Fr ₂ kN	Fa ₂ kN	n ₂ min ⁻¹	P kW	T _N Nm	Fr ₁ kN	Fr ₂ kN	Fa ₂ kN	n ₂ min ⁻¹	P kW	T _N Nm	Fr ₁ kN	Fr ₂ kN	Fa ₂ kN
4,57	1,2379	383	1057	25304	12,5	3,00	37,6	317	900,0	25994	12,5	3,00	37,6	254	740,4	26730	12,5	3,00	37,6	212	641,0	27674	12,5	3,00	37,6
5,13	1,1756	341	1057	28422	11,9	3,00	37,6	283	900,0	29196	11,9	3,00	37,6	226	740,4	30023	11,9	3,00	37,6	189	641,0	31084	11,9	3,00	37,6
5,79	1,1164	302	1057	32081	12,3	3,00	37,6	250	900,0	32955	12,3	3,00	37,6	200	740,4	33889	12,3	3,00	37,6	167	641,0	35086	12,3	3,00	37,6
6,58	1,0602	266	1057	36438	12,6	3,00	34,5	220	900,0	37431	12,6	3,00	34,5	176	740,4	38491	12,6	3,00	34,5	147	641,0	39851	12,6	3,00	34,5
7,03	1,0237	249	1026	37798	13,0	3,00	31,2	206	900,0	40004	13,0	3,00	31,2	165	740,4	41138	13,0	3,00	31,2	138	641,0	42591	13,0	3,00	31,2
8,09	0,9675	216	1026	43471	13,0	3,00	27,4	179	900,0	46009	13,0	3,00	27,4	143	740,4	47312	13,0	3,00	27,4	120	641,0	48984	13,0	3,00	27,4
8,71	0,9170	201	1026	46808	13,7	3,00	24,6	167	900,0	49541	13,7	3,00	24,6	133	740,4	50944	13,7	3,00	24,6	111	641,0	52744	13,7	3,00	24,6
10,20	0,8775	172	1026	54818	14,0	3,00	21,0	142	900,0	58018	14,0	3,00	21,0	114	718,7	57913	14,0	3,00	21,0	95	630,0	60709	14,0	3,00	21,0
11,10	0,8494	158	1000	58151	14,4	3,00	21,0	131	832,5	58427	14,4	3,00	21,0	105	710,0	62287	14,4	3,00	21,0	87	572,9	60104	14,4	3,00	21,0
12,14	0,7987	144	900,0	57257	14,5	3,00	21,9	119	750,5	57624	14,5	3,00	21,9	96	630,0	60465	14,5	3,00	21,9	80	522,1	59924	14,5	3,00	21,9
13,36	0,7987	131	800,0	55998	14,7	3,00	24,8	109	656,0	55418	14,7	3,00	24,8	87	560,0	59135	14,7	3,00	24,8	73	456,0	57585	14,7	3,00	24,8
14,94	0,7820	117	580,0	45407	15,8	3,00	26,3	97	500,0	47242	15,8	3,00	26,3	78	416,9	49238	15,8	3,00	26,3	65	360,4	50903	15,8	3,00	26,3
16,27	0,7539	108	580,0	49435	16,1	3,00	23,7	89	500,0	51433	16,1	3,00	23,7	71	416,9	53606	16,1	3,00	23,7	60	360,4	55418	16,1	3,00	23,7
17,80	0,7370	98	580,0	54082	16,5	3,00	18,7	81	500,0	56269	16,5	3,00	18,7	65	416,9	58646	16,5	3,00	18,7	54	360,4	60629	16,5	3,00	18,7
19,58	0,7026	89	560,0	57453	16,8	3,00	20,2	74	466,9	57812	16,8	3,00	20,2	59	400,0	61910	16,8	3,00	20,2	50	323,8	59933	16,8	3,00	20,2

Potenze termiche / Thermal power / Thermische Grenzleistung PtN [kW]
(senza raffreddamento / Without cooling / ohne Kühlung)

368

802-820

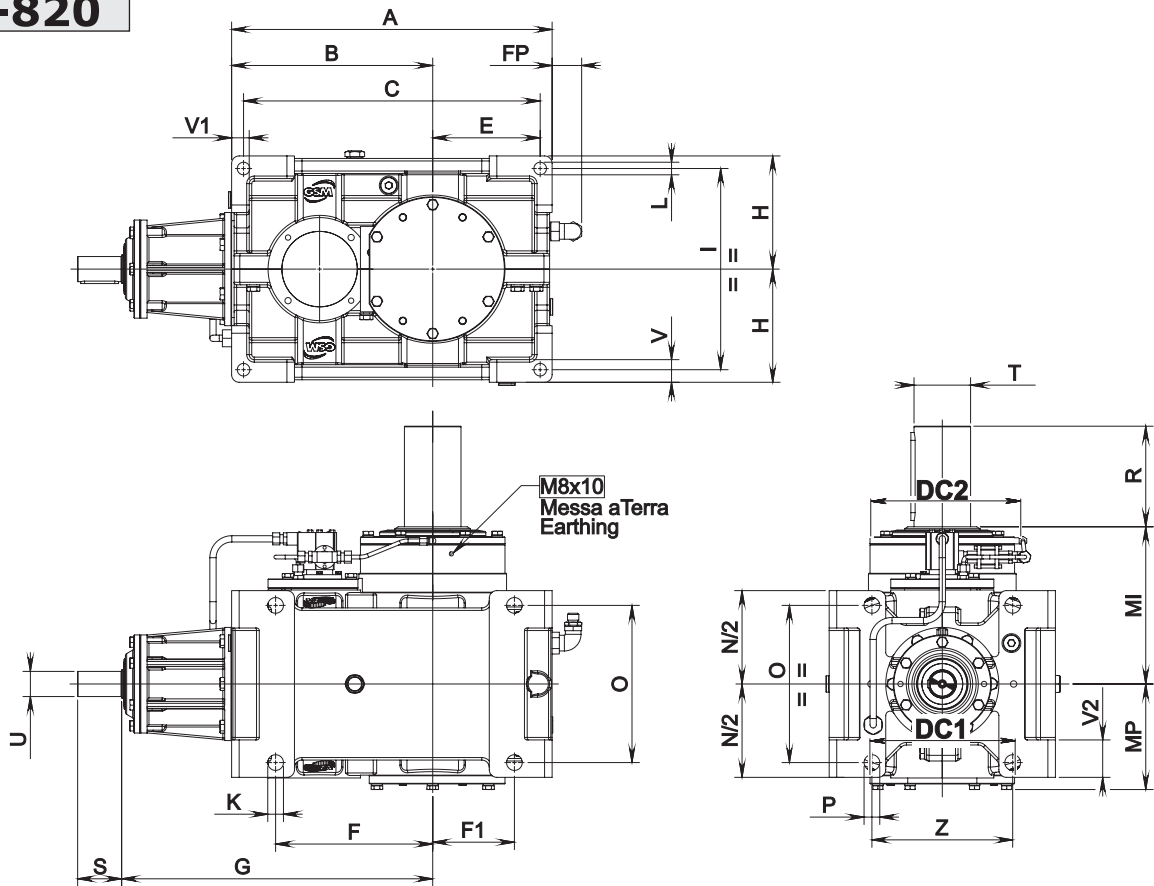

822-824

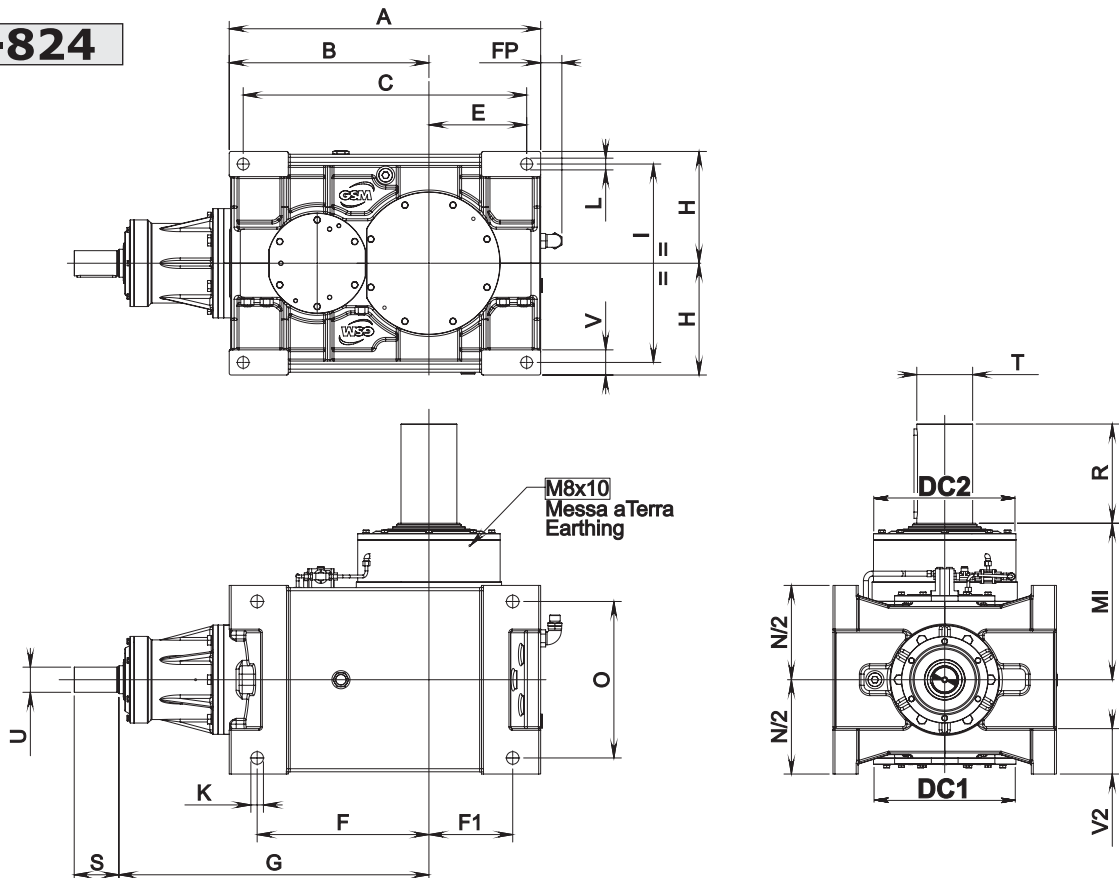

1.11 Dimensioni

1.11 Dimensions

1.11 Abmessungen

RXO1	Dimensioni generali / Dimensions / Allgemeine Abmessungen																		Kg			
	A	B	C	DC1	DC2	E	F	F1	Fp	H h11	I	K	L	N/2 h11	MP	O	P	V		V1	V2	Z
802	355	225	327	161	161	116	175	90	42	125	224	18	14	106.5	120	180	18	25	20	44.5	160	82
804	402	252	370	180	180	134	196	104	49	140	250	20	16	118.5	134	200	20	28	22.5	49	180	114
806	455	285	421	204	204	153	222	117	49	160	280	22	18	134.5	150	225	22	32	25	56.5	200	154
808	510	320	472	230	230	171	250	130	49	180	320	25	20	148.5	168	250	25	36	28	59.5	224	211
810	570	360	530	248	248	190	280	145	57	200	360	27	22	167.5	187	280	27	40	32	67.5	250	292
812	645	405	600	284	284	217.5	315	160	57	225	400	30	24	189.5	207	315	30	45	36	78.5	280	387
814	715	450	665	312	309	240	350	180	57	250	450	33	27	213.5	231	355	33	50	40	89	320	561
816	805	505	749	361	358	272	393	203	61	280	500	36	30	239.5	263	400	36	56	45	96.5	360	782
818	910	570	846	410	410	308	445	230	61	315	560	39	35	270.5	—	450	39	63	50	114.5	400	1090
820	1020	640	948	450	445	344	500	260	61	355	638	42	39	299.5	—	500	42	70	56	124	450	1522
822	1115	715	1015	510	510	350	615	300	76	400	710	45	42	337.5	—	560	—	90	—	163	—	2126
824	1255	805	1145	542	542	395	675	320	76	450	800	48	45	380.5	—	630	—	100	—	176	—	2971

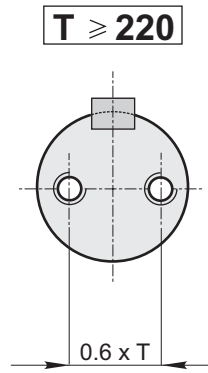
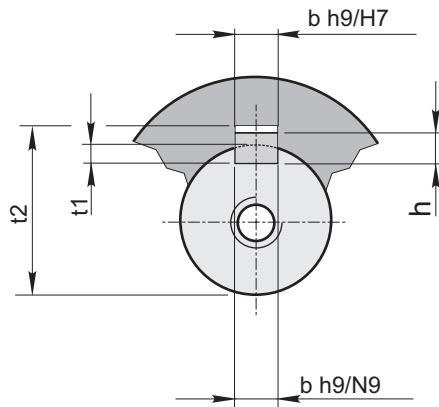
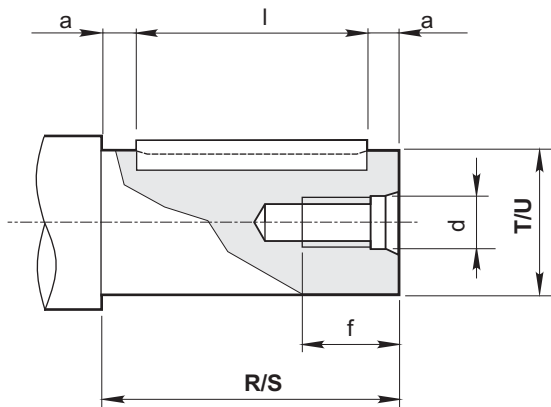

1.12.1 - Estremità d'albero entrata

1.12.1 - Input shaft end

1.12.1 - Ende der Antriebswelle

ECE	ECE			Foro fil. testa Tapped hole Gewindebohrung Kopf		Cava Keyway Nut			Estremità d'albero Shaft end Wellenend			Linguetta Key Federkeil
	U	S	G	d	f	b	t ₁	t ₂	U	S a11	a	bxhxl
802	28 j6	50	350	M8	22	8	4	31.3	28 j6	50	2.5	8x7x45
804	32 k6	56	390	M8	22	10	5	35.3	32 k6	56	3	10x8x50
806	35 k6	63	440	M10	27	10	5	38.3	35 k6	63	4	10x8x55
808	40 k6	70	495	M10	27	12	5	43.3	40 k6	70	5	12x8x60
810	45 k6	80	555	M10	27	14	5.5	48.8	45 k6	80	5	14x9x70
812	50 k6	90	625	M12	35	14	5.5	53.8	50 k6	90	5	14x9x80
814	55 m6	100	700	M12	35	16	6	59.3	55 m6	100	5	16x10x90
816	60 m6	112	780	M12	35	18	7	64.4	60 m6	112	6	18x11x100
818	70 m6	125	880	M16	39	20	7.5	74.9	70 m6	125	7.5	20x12x110
820	80 m6	140	990	M16	39	22	9	85.4	80 m6	140	7.5	22x14x125
822	90 m6	160	1110	M16	39	25	9	95.4	90 m6	160	10	25x14x140
824	100 m6	180	1250	M20	46	28	10	106.4	100 m6	180	10	28x16x160

1.12.2 - Estremità d'albero uscita

1.12.2 - Input shaft out

1.12.2 - Ende der Abtriebswelle

RX	Ø Albero Ø Shaft Ø Welle		Foro fil. testa Tapped hole Gewindebohrung Kopf		Cava Keyway Nut			Estremità d'albero Shaft end Wellenende		Linguetta Key Federkeil
	T	MI	d	f	b	t ₁	t ₂	R a11	a	bxhxl
802	60 m6	180	M12	35	18	7	64.4	112	6	18x11x100
804	70 m6	200	M16	39	20	7.5	74.9	125	7.5	20x12x110
806	80 m6	225	M16	39	22	9	85.4	140	7.5	22x14x125
808	90 m6	250	M16	39	25	9	95.4	160	10	25x14x140
810	100 m6	280	M20	46	28	10	106.4	180	10	28x16x160
812	110 m6	315	M20	46	28	10	116.4	200	10	28x16x180
814	125 m6	355	M20	46	32	11	132.4	225	12.5	32x18x200
816	140 m6	400	M24	56	36	12	148.4	250	15	36x20x220
818	160 m6	450	M24	56	40	13	169.4	280	15	40x22x250
820	180 m6	500	M30	72	45	15	190.4	315	17.5	45x25x280
822	200 m6	560	M30	72	45	15	210.4	355	17.5	45x25x320
824	220 m6	630	N°2 M24	56	50	17	231.4	400	20	50x28x360

Estremità d'albero cilindriche secondo UNI 6397-68, DIN748, NFE 22.051, BS 4506-70, ISO/R 775/69, escluso corrispondenza R-S.
Linguette secondo UNI6604-69, DIN6885 Bl. 1-68, NFE 27.656 e 22.175, BS 4235.1-72, ISO/R 773/69, escluso corrispondenza I.

Cylindrical shaft ends in accordance with UNI 6397-68, DIN748, NFE 22.051, BS 4506-70, ISO/R 775/69, excluding section R-S.
Key according to UNI6604-69, DIN6885 Bl. 1-68, NFE 27.656 e 22.175, BS 4235.1-72, ISO/R 773/69, excluding section I.

Zylindrische Wellenenden gemäß UNI 6397-68, DIN748, NFE 22.051, BS 4506-70, ISO/R 775/69, ausgenommen Zuordnung R-S.
Federkeile UNI6604-69, DIN6885 Bl. 1-68, NFE 27.656 und 22.175, BS 4235.1-72, ISO/R 773/69, ausgenommen Zuordnung I.

814-820

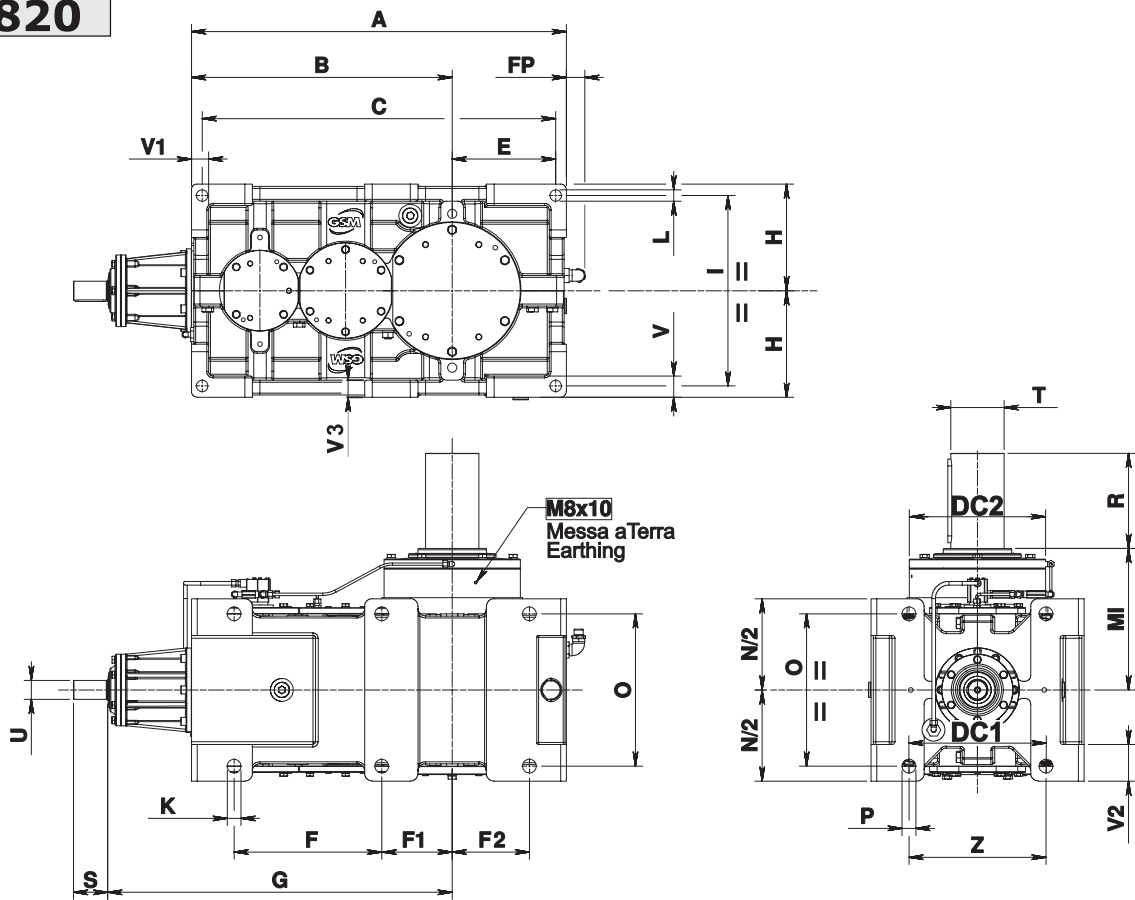

1.11 Dimensioni

1.11 Dimensions

1.11 Abmessungen

RX02	Dimensioni generali / Dimensions / Allgemeine Abmessungen																				Kg		
	A	B	C	DC1	DC2	E	F	F1	F2	Fp	H _{h11}	I	K	L	N _{h11}	O	P	V	V1	V2		V3	Z
814	875	610	825	312	309	240	345	165	180	57	250	450	33	27	213.5	355	33	50	40	89	40	320	659
816	985	685	929	361	358	272	388	185	203	61	280	500	36	30	239.5	400	36	56	45	96.5	45	360	917
818	1110	770	1046	410	410	308	437.5	207.5	230	61	315	560	39	35	270.5	450	39	63	50	114.5	48	400	1281
820	1245	865	1173	450	445	344	492.5	232.5	260	61	355	638	42	39	299.5	500	42	70	56	124	56	450	1789

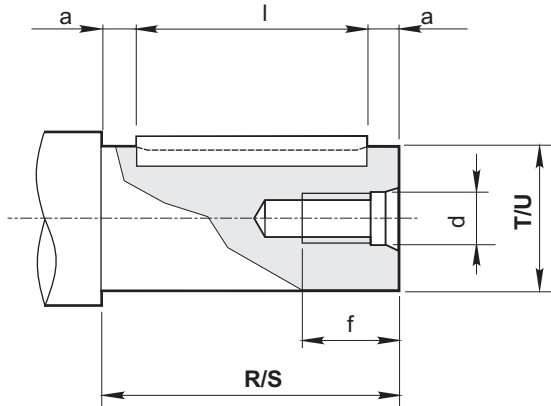

1.12.1 - Estremità d'albero entrata

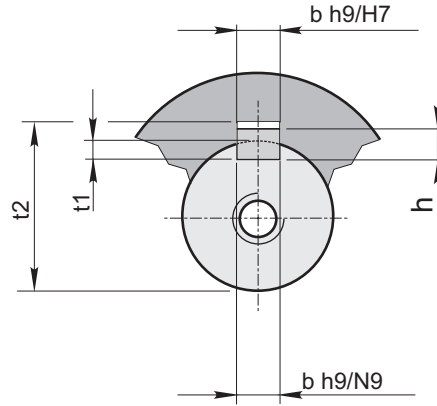

1.12.1 - Input shaft end

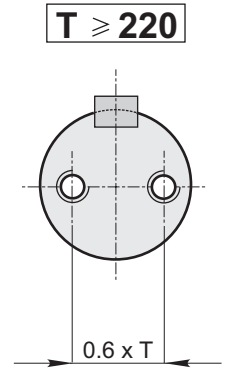

1.12.1 - Ende der Antriebswelle

ECE	ECE			Foro fil. testa Tapped hole Gewindebohrung Kopf		Cava Keyway Nut			Estremità d'albero Shaft end Wellenend			Linguetta Key Federkeil
	U	S	G	d	f	b	t ₁	t ₂	U	S a11	a	bxhxl
814	45 k6	80	805	M10	27	14	5.5	48.8	45 k6	80	5	14x9x70
816	50 k6	90	905	M12	35	14	5.5	53.8	50 k6	90	5	14x9x80
818	55 m6	100	1020	M12	35	16	6	59.3	55 m6	100	5	16x10x90
820	60 m6	112	1140	M12	35	18	7	64.4	60 m6	112	6	18x11x100

1.12.2 - Estremità d'albero uscita

1.12.2 - Input shaft out

1.12.2 - Ende der Abtriebswelle

RX	Ø Albero Ø Shaft Ø Welle		Foro fil. testa Tapped hole Gewindebohrung Kopf		Cava Keyway Nut			Estremità d'albero Shaft end Wellenende		Linguetta Key Federkeil
	T	MI	d	f	b	t ₁	t ₂	R a11	a	bxhxl
814	125 m6	355	M20	46	32	11	132.4	225	12.5	32x18x200
816	140 m6	400	M24	56	36	12	148.4	250	15	36x20x220
818	160 m6	450	M24	56	40	13	169.4	280	15	40x22x250
820	180 m6	500	M30	72	45	15	190.4	315	17.5	45x25x280

Estremità d'albero cilindriche secondo UNI 6397-68, DIN748, NFE 22.051, BS 4506-70, ISO/R 775/69, escluso corrispondenza R-S.
Linguette secondo UNI6604-69, DIN6885 Bl. 1-68, NFE 27.656 e 22.175, BS 4235.1-72, ISO/R 773/69, escluso corrispondenza I.

Cylindrical shaft ends in accordance with UNI 6397-68, DIN748, NFE 22.051, BS 4506-70, ISO/R 775/69, excluding section R-S.
Key according to UNI6604-69, DIN6885 Bl. 1-68, NFE 27.656 e 22.175, BS 4235.1-72, ISO/R 773/69, excluding section I.

Zylindrische Wellenenden gemäß UNI 6397-68, DIN748, NFE 22.051, BS 4506-70, ISO/R 775/69, ausgenommen Zuordnung R-S.
Federkeile UNI6604-69, DIN6885 Bl. 1-68, NFE 27.656 und 22.175, BS 4235.1-72, ISO/R 773/69, ausgenommen Zuordnung I.



1.13 Accessori

1.13 Accessories

1.13 Zubehör

Sistema con ventola - VE

Fan cooling - VE

System mit Lüfterrad - VE

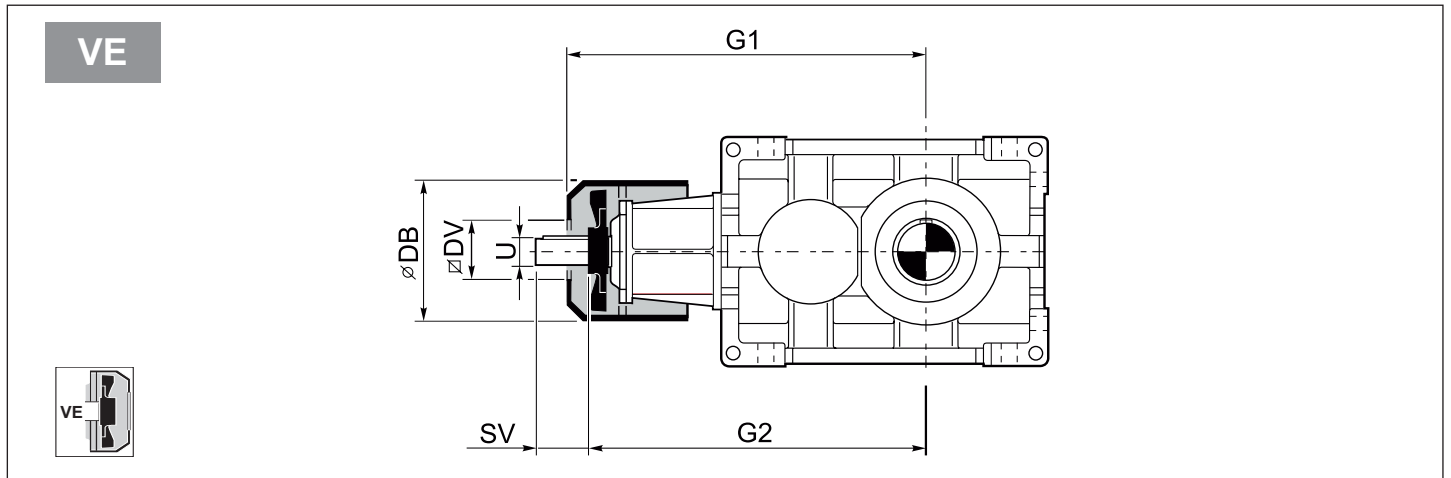

	RXO1											
	G1	G2	∅ DB	∅ DV	SV						U	
					i<11	i<12	i<13	i>11	i>12	i>13		
802	403	369	176	89		31				31		28 j6
804	454	416	220	98		30				30		32 k6
806	504	466	220	98		37				37		35 k6
808	557	521	220	98	70			44				40 k6
810	633	585	260	118		80				50		45 k6
812	702	655	260	118		90				60		50 m6
814	793	738	310	138		100				62		55 m6
816	871	818	310	138		112				74		60 m6
818	1009	930	394	214			125				75	70 m6
820	1116	1040	394	214	140			90				80 m6

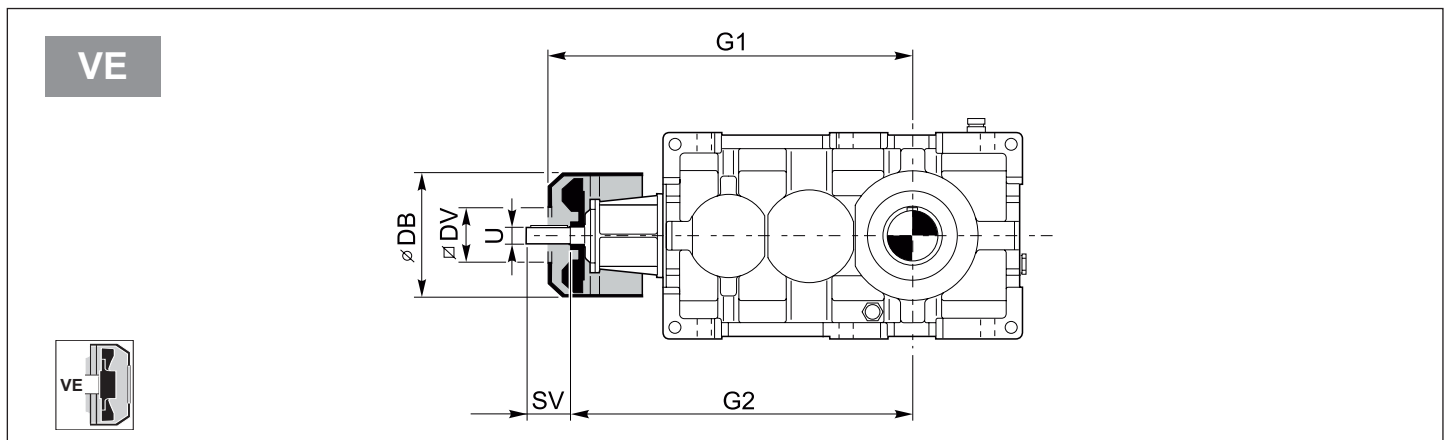

	RXO2						
	G1	G2	∅ DB	∅ DV	SV RX02 i ≤ 47.5	SV RX02 i > 47.5	U
814	883	835	260	118	80	50	45 k6
816	983	935	260	118	90	60	50 k6
818	1113	1058	310	138	100	62	55 m6
820	1231	1178	310	138	112	74	60 m6

1.13 Accessori

1.13 Accessories

1.13 Zubehör

Antiretro

Backstop

Rücklaufsperre

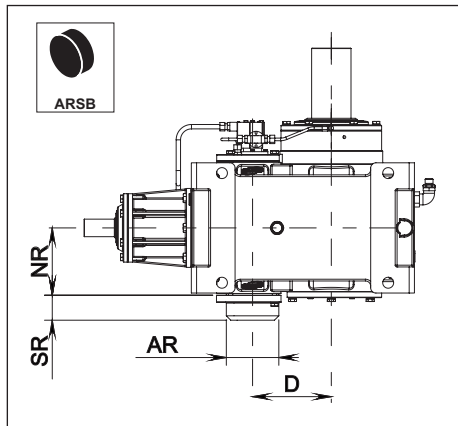

	RXO1 - RXV1			
	NR	SR	AR	D
802	109.5	60	90	125
804	120.5	60	100	140
806	135.5	60	110	160
808	149.5	60	120	180
810	163.5	90	130	200
812	190	90	150	225
814	212	90	170	250
816	236.5	110	180	280
818	248.5	110	200	320
820	250	114	255	360
822	A richiesta - On request - Auf Anfrage			
824				

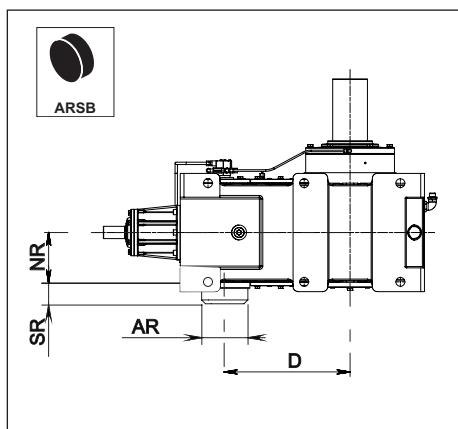

	RXO2 - RXV2			
	NR	SR	AR	D
814	177.5	86	130	450
816	200	81	150	505
818	225	67	170	570
820	250	97	180	640

U

ACC. - OPT - ACCESSORI E OPZIONI
 ACC. - OPT - ACCESSORIES AND OPTIONS
 ACC. - OPT - ZUBEHÖR UND OPTIONEN

Accessori - Dispositivi
 ACC.

Accessories devices
 ACC.

Zubehör - Vorrichtungen
 ACC.

Accessories



Possono essere forniti i seguenti accessori e dispositivi

Some devices can optionally be provided

Folgende Zubehörteile und Vorrichtungen können geliefert werden:

- Designation**
- 1** Cooling
- 2** Backstop
- ACC6**
- Bearing lubrication
- ACC7.**
- 7A** Vibration Sensor
- 7B** Vibration SWITCH
- 7G** OIL LEVEL SWITCH
- 7H** HEATERS
- 7I** PT 100 - SENSOR
- 7M** Pressure switch
- ACC8**
- Sealing
- OPT**
- Material_Oil seals

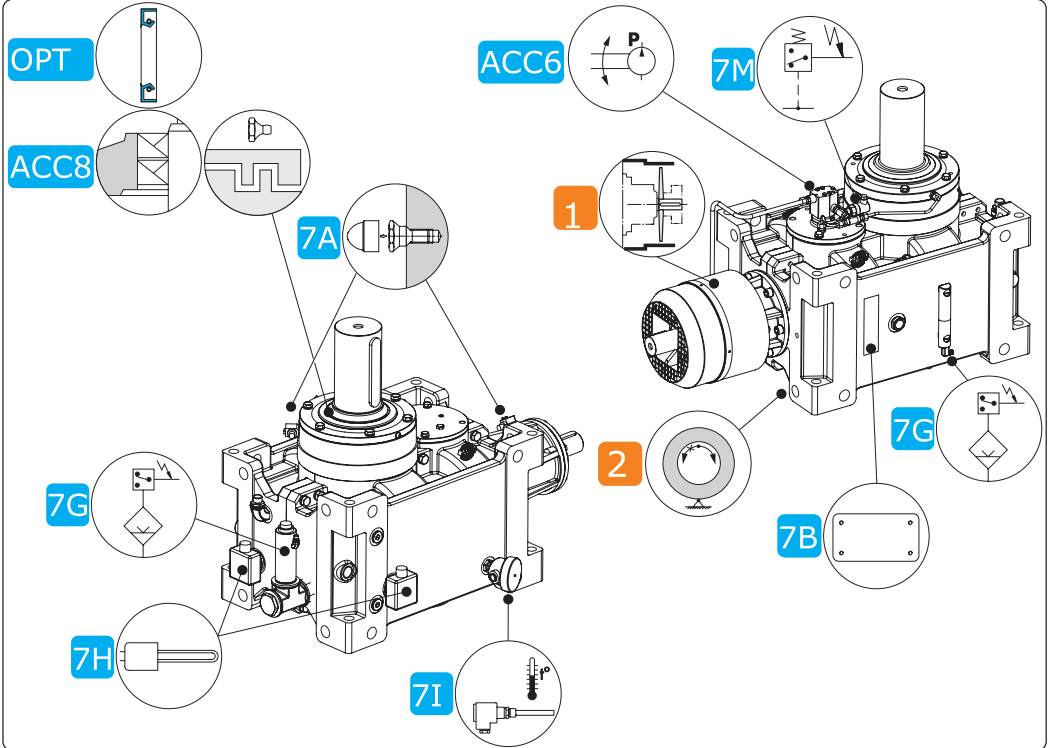

		ACC6	ACC6 - Accessori - Lubrificazione Forzata - BEARING	ACC6 - Accessories - Forced lubrication - BEARING	ACC6 - Zubehör - Zwangsschmierung - BEARING	U2
ACC7-R	Hydraulic accessories	ACC7A	Accessori idraulici - Vibration Sensor	Hydraulic accessories - Vibration Sensor	Hydraulikzubehör - Vibration Sensor	U3
		ACC7B	Accessori idraulici - Vibration SWITCH	Hydraulic accessories - Vibration SWITCH	Hydraulikzubehör - Vibration SWITCH	U4
		ACC7G	Accessori idraulici - LEVEL	Hydraulic accessories - LEVEL	Hydraulikzubehör - LEVEL	U6
		ACC7H	Accessori idraulici - HEATER	Hydraulic accessories - HEATER	Hydraulikzubehör - HEATER	U12
		ACC7I1	Accessori idraulici - TEMPERATURE SENSOR	Hydraulic accessories - TEMPERATURE SENSOR	Hydraulikzubehör - TEMPERATURE SENSOR	U16
		ACC7M2	Accessori idraulici - PRESSURE SWITCH	Hydraulic accessories - PRESSURE SWITCH	Hydraulikzubehör - PRESSURE SWITCH	U25
ACC8-R		ACC8	ACC8 - Accessori - Tipo Tenute	ACC8 - Accessories - Seal Type	ACC8 - Zubehör - Typ von Dichtung	U29
OPT		OPT	OPT - Opzioni - Materiale degli anelli di tenuta	OPT - Options - Materials of Seals	OPT - Optionen - Dichtungsstoffe	U32





2.0 - Lubrificazione forzata

2.0 - Forced lubrication

2.0 - Zwangsschmierung

ACC6	ACC6 - Accessori - Lubrificazione Forzata - BEARING	ACC6 - Accessories - Forced lubrication - BEARING	ACC6 - Zubehör - Zwangsschmierung - BEARING
-------------	--	--	--

ACC6

Bearing lubrication

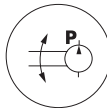

La lubrificazione dei cuscinetti sopra al livello dell'olio è garantita come segue:
- Grasso
- Olio
ATEX – sono forniti con cuscinetti lubrificati a grasso.

Per le condizioni di consegna fare riferimento alla sezione specifica.

Possono essere forniti i seguenti accessori e dispositivi:

The lubrication of the bearings above oil level is ensured as follows:
- Grease
- Oil
ATEX - are supplied with grease lubricated bearings.

For the delivery conditions refer to the specific paragraph.

Some devices can optionally be provided:

Die Schmierung der Lager, über den Ölfüllstand hinaus, wird folgendermaßen gewährleistet:
- mit Fett
- mit Öl
ATEX – werden mit fettgeschmierten Lagern geliefert.

Bezüglich der Lieferbedingungen ist Bezug auf den spezifischen Abschnitt zu nehmen.

Folgende Zubehörteile und Vorrichtungen können geliefert werden:

Code Designation	Code ORDER	I	GB	DE
LFP3	---	= Pompa asservita - 1.75 l/min	= Shaft-driven pump - 1.75 l/min	= Nebenpumpe- 1.75 l/min

2.1 - Applicabilità

2.1 - Application

2.1 - Applikation

Pos. Mont. M5 - M6

Mntg. Pos. M5 - M6

Einbaulage M5 - M6

	Grandezza / Size / Baugröße											
	802	804	806	808	810	812	814	816	818	820	822	824
$n_1 \geq n_{1min}$	G (grease)			LFP3								
$n_1 < n_{1min}$	G (grease)											
	G (grease)											

I valori di n_1 min sono riportati nel paragrafo Verifiche, punto 1).

n_1 min values are listed at paragraph Verification, point 1).

Die Werte von n_1 min werden im Paragraph "Kontrollen", Punkt 1, angegeben.

2.2 - Pompa asservita

Questo sistema si realizza accoppiando la pompa direttamente all'albero del riduttore, dal quale prende il moto.
In questa famiglia di prodotti è utilizzata la pompa asservita LFP3.

2.2 - Shaft-driven pump

This system is created by coupling the pump directly to the gearbox shaft, which conveys motion.
This product family uses LFP3 interlocked pump.

2.2 - Nebenpumpe

Dieses System entsteht mittels direkter Kupplung der Pumpe an die Getriebewelle, von der sie angetrieben wird.

Pompa con portata di 1.75 l/min a 750 rpm
Questa pompa è particolarmente indicata per un funzionamento a basso numero di giri, viene ad esempio utilizzata nel primo stadio di riduzione cilindrico di un riduttore ortogonale

Pump with 1.75 l/min capacity at 750 rpm
This pump is especially suited for low speed operation. A typical application is the first reduction spur gear set of a helical bevel gear unit.

Pumpe mit Durchsatz von 1,75 l/min bei 750 U/min
Diese Pumpe ist besonders für einen Betrieb bei niedriger Drehzahl geeignet. Sie wird z.B. in der ersten zylindrischen Übersetzungsstufe eines Kegelstirnradgetriebes verwendet.

LFP3

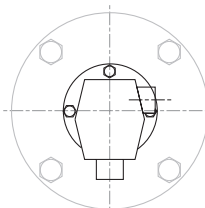
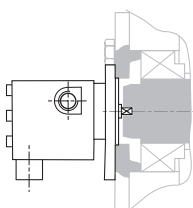

ACC7A	Accessori idraulici - Vibration Sensor	Hydraulic accessories - Vibration Sensor	Hydraulikzubehör - Vibration Sensor
--------------	---	---	--

7A Vibration Sensor

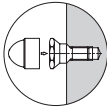

Predisposizione per installazione sensori di vibrazioni. La predisposizione è disponibile sia in ingresso che in uscita

Connection for vibration sensor installation. The connection is available as both input and output

Auslegung für die Installation der Schwingungssensoren. Diese Auslegung ist sowohl am Ein- als auch am Ausgang verfügbar

Possono essere forniti i seguenti accessori e dispositivi:

Some devices can optionally be provided:

Folgende Zubehörteile und Vorrichtungen können geliefert werden:

Code Designation	Code ORDER	I	GB	DE
A_PHZ1	---	= PREDISPOSIZIONE - Accelerometro - Entrata	= CONNECTION - Accelerometer - Input	= AUSLEGUNG - Beschleunigungsmesser - Eingang
A_PHZ2	---	= PREDISPOSIZIONE - Accelerometro - Uscita	= CONNECTION - Accelerometer - Output	= AUSLEGUNG - Beschleunigungsmesser - Ausgang
A_PHZ	---	= PREDISPOSIZIONE - Accelerometro - Entrata - Uscita	= CONNECTION - Accelerometer - Input - Output	= AUSLEGUNG - Beschleunigungsmesser - Eingang - Ausgang

RX01

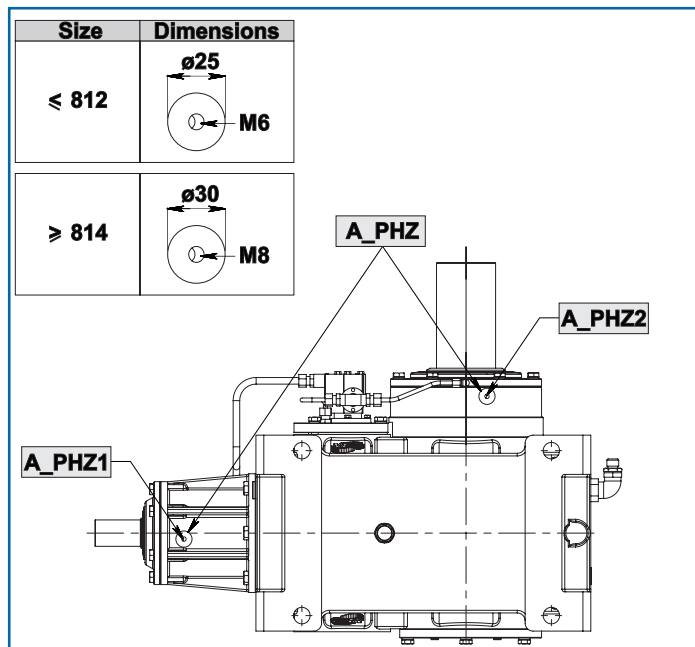

RX02

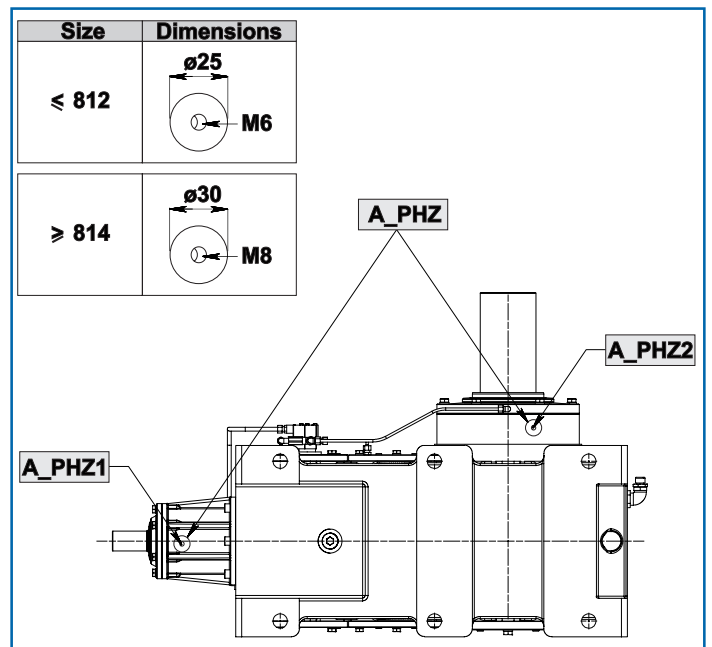

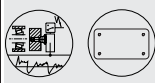

ACC7B	Accessori idraulici - Vibration SWITCH	Hydraulic accessories - Vibration SWITCH	Hydraulikzubehör - Vibration SWITCH
--------------	---	---	--

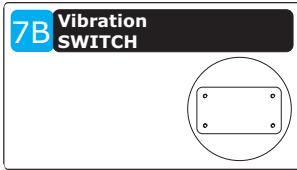

Predisposizione per installazione "Vibration Switch"

Connection for "Vibration Switch" installation

"Vibration

Auslegung für die Installation eines „Vibration Switch“

Possono essere forniti i seguenti accessori e dispositivi:

Some devices can optionally be provided:

Folgende Zubehörteile und Vorrichtungen können geliefert werden:

Code Designation	Code ORDER	I	GB	DE
B_PVS1	---	= PREDISPOSIZIONE - Vibration SWITCH - - Type1A	= CONNECTION for - Vibration SWITCH - - Type1A	=AUSLEGUNG - Vibration SWITCH - - Type1A
B_PVS2	---	= PREDISPOSIZIONE - Vibration SWITCH - - Type1B	= CONNECTION for - Vibration SWITCH - - Type1B	=AUSLEGUNG - Vibration SWITCH - - Type1B

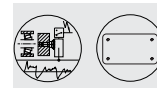

RX01

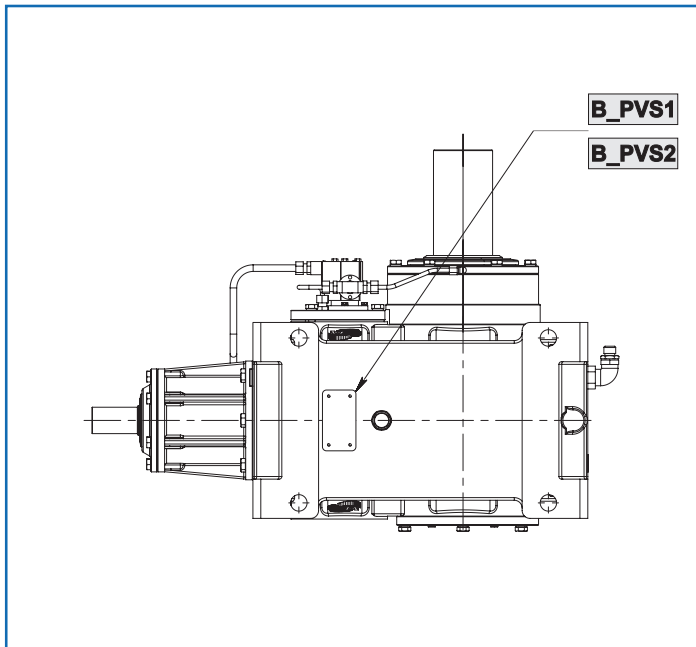

RX02

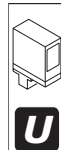
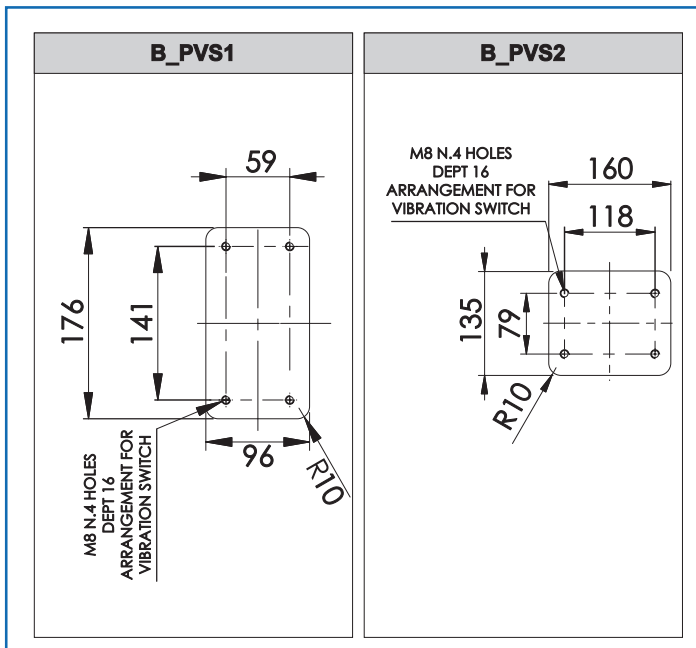
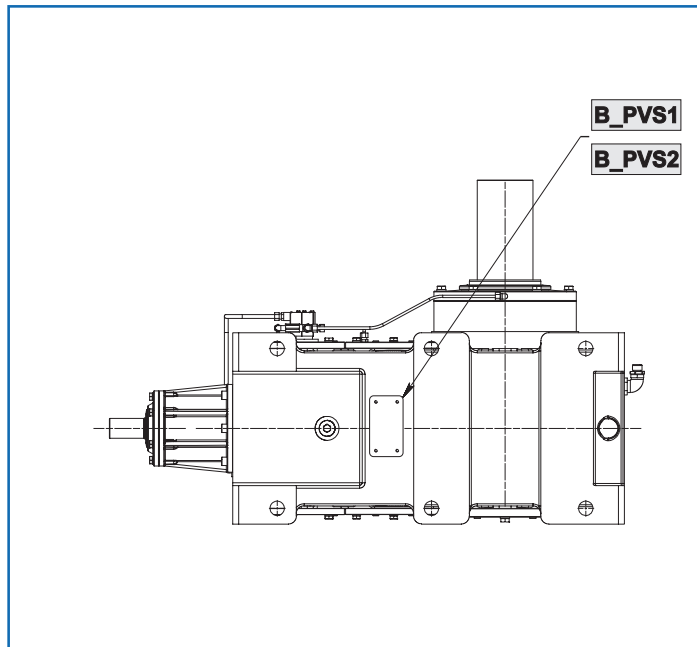

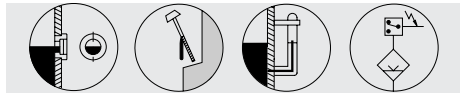

3.0 - Accessori idraulici

3.0 - Hydraulic accessories

3.0 - Hydraulikzubehör

ACC7G	Accessori idraulici - LEVEL	Hydraulic accessories - LEVEL	Hydraulikzubehör - LEVEL
--------------	------------------------------------	--------------------------------------	---------------------------------

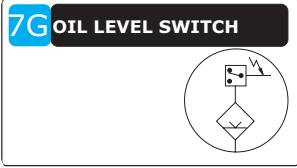

Per controllare il livello dell'olio nel riduttore, può essere fornito un interruttore di livello olio. L'interruttore può far scattare un allarme quando il livello dell'olio scende al di sotto di un valore specifico

To control the oil level in the gear unit, an oil level switch can be provided. The switch can trigger an alarm signal when the oil level falls beneath a specified

Für die Füllstandkontrolle des sich im Getriebe befindlichen Öls kann ein Ölfüllstandschalter geliefert werden. Dieser Schalter kann einen Alarm auslösen, sobald der Ölfüllstand unter einen bestimmten Wert sinkt

Possono essere forniti i seguenti accessori e dispositivi:

Some devices can optionally be provided:

Folgende Zubehörteile und Vorrichtungen können geliefert werden:

Code Designation	Code ORDER	I	GB	DE
G_L4A	4411270001	= Livello stato visivo - Type4A- NO	= Level switch with sight window - Type4A- NO	= Schauglas - Type4A- NO
G_L4B	4411270003	= Livello stato visivo - Type4B- NC	= Level switch with sight window - Type4B- NC	= Schauglas - Type4B- NC
G_L5D	4411500001	= Livello stato a galleggiante - Type5D	= Float level switch - Type5D	= Pegelwächter - Type5D

TECHNICAL DATASHEET



G_L4A

G_L4B

Indicatori di livello a colonna

Pillar level gauges

Säulen-Füllstandanzeigen

MATERIALE

Tecnopolimero trasparente a base poliammidica (PA-T). Alta resistenza a urti, solventi, oli additivati, idrocarburi alifatici e aromatici, benzine, nafta, esteri fosforici. Evitare il contatto con alcool o con miscele di lavaggio contenenti alcool.

MATERIAL

Polyamide-based transparent engineering polymer (PA-T). High resistance to shocks, solvents, allied oil, aliphatic and aromatic hydrocarbons, petrol, naphtha, phosphoric esters. Avoid any contact with alcohol or washing mixtures containing alcohol.

MATERIAL

Transparentes Technopolymer auf Polyamidbasis (PA-T). Hohe Festigkeit gegenüber Stößen, Lösungsmitteln, mit Zusatzstoffen bereicherten Ölen, aliphatischen und aromatischen Kohlenwasserstoffen, Benzin, Dieselmotortreibstoff, Phosphorsäureestern. Der Kontakt mit Alkohol oder Reinigungsgemischen, die Alkohol enthalten, ist zu vermeiden.

VITI, DADI E RONDELLE

Acciaio zincato lucido.

SCREWS, NUTS AND WASHERS

Polished galvanised steel.

SCHRAUBEN, MUTTERN UND UNTERLEGSCHIEBEN

Verzinkter Stahl, glänzend.

GUARNIZIONI DI TENUTA

OR gomma sintetica NBR. Rugosità della superficie di appoggio della guarnizione Ra = 3 µm.

SEALS

NBR synthetic rubber O-ring. Seal resting surface roughness Ra = 3 µm.

DICHTUNGEN

O-Ringe aus synthetischem Kautschuk NBR. Rauheit der Auflagefläche der Dichtung Ra = 3 µm.

GALLEGGIANTE

Tecnopolimero espanso a base poliammidica (PA), colore nero, incorporante un elemento magnetico per l'attivazione del contatto elettrico quando il galleggiante raggiunge la soglia di allarme posta a circa 50 mm sopra l'asse del dado inferiore (dati riferiti a olio minerale tipo CB68, secondo ISO 3498, temperatura 23°C).

FLOAT

Black polyamide-based engineering plastic foam (PA), including a magnetic element to enable the electric contact once the float reaches the warning threshold located at about 50 mm above the axis of the lower nut (data concerning CB68 mineral oil, according to ISO 3498, temperature 23°C).

SCHWIMMER

Schaum-Technopolymer auf Polyamidbasis (PA), schwarz, mit integriertem magnetischen Element zur Aktivierung des elektrischen Kontakts, wenn der Schwimmer die auf ungefähr 50 mm oberhalb der Achse der unteren Mutter gesetzte Alarmschwelle erreicht (auf Mineralöl-Typ CB68, nach ISO 3498, Temperatur 23 °C bezogene Daten).

SQUADRETTA CON SENSORE

A perfetta tenuta stagna in tecnopolimero a base polipropilena (PP), colore nero, incorporante il relé (reed) con due conduttori cablati al connettore bipolare.

BRACKET WITH SENSOR

Black, watertight polypropylene-based engineering polymer (PP), including the relay (reed) with two conductors wired to the bipolar connector.

BEFESTIGUNGSWINKEL MIT SENSOR

Mit perfekter Abdichtung aus Technopolymer auf Polyamidbasis (PP), schwarz, im Relais (reed) integriert mit zwei an den zweipoligen Steckern verkabelten Leitern.

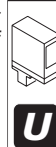

3.0 - Accessori idraulici

3.0 - Hydraulic accessories

3.0 - Hydraulikzubehör

TECHNICAL DATASHEET

CONNETTORE BIPOLARE ORIENTABILE

Con pressacavo e portacontatti incorporati. Uscita frontale o laterale (dx o sx) che offre una completa protezione contro getti d'acqua (grado di protezione IP 65 come da tabella IEC 529)

ADJUSTABLE BIPOLAR CONNECTOR

Cable entry and contact holder included. Front or side (RH or LH) output providing complete protection against water jets (IP 65 protection level according to IEC 529 table)

AUSRICHTBARER ZWEIPOLIGER STECKER

Mit Kabelverschraubung und eingebauten Kontaktfassungen. Frontalte und seitlicher Ausgang (rechts oder links), der einen vollständigen Schutz gegen Wasserspritzer bietet (Schutzart IP 65 gemäß Tabelle IEC 529)

MOSTRINA

Alluminio laccato bianco. Alloggiata nell'apposita sede posteriore esterna quindi non a contatto diretto con il fluido. Può essere sfilata prima del montaggio dalla parte con l'invito per tracciare linee di livello o diciture.

PLATE

White lacquered aluminium. Located in the corresponding external rear housing, avoiding any direct contact with the liquid. Before installation, it can be removed from the side featuring the mark to trace contours or inscriptions.

EINFASSUNG

Weiß lackiertes Aluminium. Da in einem entsprechenden externen Sitz an der Rückseite angeordnet, kommt es zu keinem direkten Kontakt mit der Flüssigkeit. Kann vor der Montage von der Laschenseite her abgezogen werden, um die Füllstandmarkierungslinien oder Beschriftungen anbringen zu können.

ESECUZIONI STANDARD

-G_L4A: con contatto elettrico normalmente aperto.
-G_L4B: con contatto elettrico normalmente chiuso.

STANDARD OPERATIONS

-G_L4A: with normally open electric contact.
-G_L4B: with normally closed electric contact.

STANDARD-AUSFÜHRUNGEN

-G_L4A: mit Schließerkontakt.
-G_L4B: mit Öffnerkontakt.

TEMPERATURA MASSIMA DI ESERCIZIO IN CONTINUO

90°C (funzionamento con olio).

CONTINUOUS MAXIMUM OPERATING TEMPERATURE

90°C (operation with oil).

MAXIMALE TEMPERATUR IM DAUERBETRIEB

90 °C (bei Betrieb mit Öl).

CARATTERISTICHE E PRESTAZIONI

L'indicatore di livello a colonna oltre al controllo visivo fornisce un segnale elettrico al raggiungimento del valore minimo del livello del fluido. Saldatura ad ultrasuoni che assicura una perfetta tenuta. Massima visibilità del livello del fluido anche da posizioni laterali. Visiera lenticolare per una maggiore visibilità del livello.

FEATURES AND PERFORMANCE

Besides visual check, the pillar level gauge provides an electrical signal once the minimum liquid level is reached. Ultrasonic sealing ensures perfect tightness. Maximum visibility of liquid level even from the sides. Magnifying lens allowing greater level visibility.

EIGENSCHAFTEN UND LEISTUNGEN

Die Säulen-Füllstandanzeige liefert zusätzlich zur Sichtkontrolle ein elektrisches Signal bei Erreichen des Mindestwerts des Flüssigkeitsstands. Ultraschall-Schweißung, die eine perfekte Dichtigkeit gewährleistet. Besonders gut, auch aus seitlichen Positionen, ersichtlicher Flüssigkeitsstand. Linsenblende für eine bessere Sicht des Füllstands.

DATI TECNICI

In prove di laboratorio effettuate con olio minerale tipo CB68 (secondo ISO 3498), a 23°C per un tempo relativamente limitato, la saldatura ha resistito fino a 13 bar.

TECHNICAL DATA

During laboratory tests performed with CB68 mineral oil (according to ISO 3498), at 23°C in a relatively short period, sealing resisted up to 13 bar.

TECHNISCHE DATEN

In mit Mineralöl vom Typ CB68 durchgeführten Labortests (nach ISO 3498) bei 23 °C und über eine relativ begrenzte Zeit hinweg, hielt die Schweißnaht bis 13 bar.

FUNZIONAMENTO DEL SENSORE ELETTRICO DI LIVELLO MIN

-G_L4A: il circuito elettrico si chiude al raggiungimento del livello di minimo.
-G_L4B: il circuito elettrico si apre al raggiungimento del livello di minimo.

MIN LEVEL ELECTRIC SENSOR OPERATION

-G_L4A: the electric circuit closes once the minimum level is reached.
-G_L4B: the electric circuit opens once the minimum level is reached.

FUNKTION DES ELEKTRISCHEN MINDESTFÜLLSTANSENSORS

-G_L4A: der Stromkreis schließt bei Erreichen des Mindestfüllstands.
-G_L4B: der Stromkreis öffnet bei Erreichen des Mindestfüllstands.

TECHNICAL DATASHEET

Caratteristiche elettriche	<i>Electric features</i>	Eigenschaften des elektrischen Teils				
Alimentazione	<i>Power supply</i>	Versorgung	AC/DC			
Contatti elettrici	<i>Electric contacts</i>	Elektrische Kontakte	NO NC	normalmente aperto normalmente chiuso	<i>Normally open</i> <i>Normally closed</i>	Schließer Öffner
Tensione max.	<i>Max. voltage</i>	Max. Spannung	NO: 150 Vac, 100 Vdc NC: 150Vac, 150 Vdc			
Intensità max. di corrente commutabile	<i>Max. intensity of switching current</i>	Max. schaltbare Stromstärke	1 A			
Intensità max. di corrente sopportabile	<i>Max. intensity of carrying current</i>	Max. verträgliche Stromstärke	NO: 1A NC: 2A			
Max. potenza commutabile	<i>Max. switching power</i>	Max. schaltbare Leistung	NO: 10 Va NC: 20 Va			
Pressacavo	<i>Cable gland</i>	Kabelverschraubung	Pg 7	per cavi in guaina Ø 6 o 7 mm	<i>For wires in sheath Ø 6 or 7 mm</i>	Für Kabel mit Ummantelung Ø6 oder 7 mm
Sezione conduttori	<i>Wire cross-section</i>	Leiterquerschnitt	Max. 1.5 mm ²			Max. 1.5 mm ²
NOTA	<i>NOTE</i>	HINWEIS		Evitare l'utilizzo di questo indicatore in prossimità di campi magnetici	<i>Avoid using this indicator close to magnetic fields</i>	Diese Anzeige sollte nicht in der Nähe von Magnetfeldern verwendet werden

Collegamenti elettrici standard:

Standard electrical connections:

Elektrische Standard-Verbindungen:

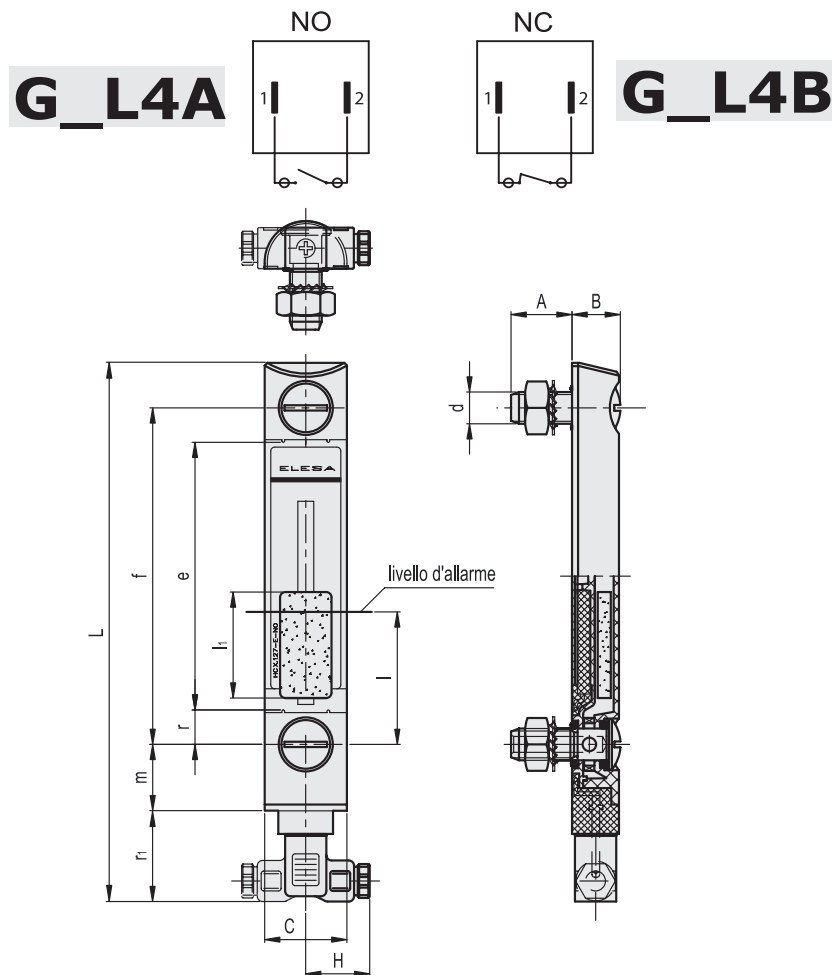

Code Designation	Code ORDER	f	d	A	B	C	H	L	e	l	l1	m	r	r1	C# [N m]	Kg
G_L4A	4411270001	127	M12	23	20	32	26	202	101	50	40	25	13	32.5	12	150
G_L4B	4411270003	127	M12	23	20	32	26	202	101	50	40	25	13	32.5	12	150

TECHNICAL DATASHEET



G_L5D

Livellostato a galleggiante

Float level switch

Schwimmerfüllstandanzeige

DESCRIZIONE

Sensore per il rilievo a distanza del livello olio con contatti reedposti all'interno del tubo scorrevole, azionati dal campomagnetico esercitato dai magneti contenuti nel galleggiante che si muove lungo il tubo stesso.

DESCRIPTION

Sensor allowing oil level remote detection with reed contacts located inside the sliding tube. They are enabled by the magnetic field created by the magnets contained in the float moving along the tube itself.

BESCHREIBUNG

Sensor zur Fernfassung des Ölpegels mit Reed-Kontakten, die im Gleitrohr angeordnet sind und vom Magnetfeld betätigt werden, das von den im Schwimmer enthaltenen Magneten erzeugt wird. Dieser Schwimmer bewegt sich am Rohr entlang.

CARATTERISTICHE GENERALI

- Ottone–Spansil–asta inox
- N° 1 punti di intervento
- Lunghezza 150 mm
- Pressione di lavoro fino a 20 Bar
- temperatura di lavoro standard fino a 100°C
- temperatura ambiente: -40/+40°C =T6, -40/+60°C =T5
- Grado di protezione minimo IP67

GENERAL FEATURES

- Brass–Spansil–stainless bar
- No. 1 operating points
- Length 150 mm
- Operating pressure up to 20 Bar
- standard working temperature up to 100°C
- ambient temperature: -40/+40°C =T6, -40/+60°C =T5
- IP67 minimum protection level

ALLGEMEINE EIGENSCHAFTEN

- Messing–Spansil–Stab aus Edelstahl
- 1 Eingriffspunkt
- Länge 150 mm
- Arbeitsdruck bis 20 bar
- Standard-Arbeitstemperatur bis 100 °C
- Umgebungstemperatur: -40/+40 °C =T6, -40/+60 °C =T5
- Min. Schutzart IP67

OMOLOGATI IN CONFORMITA' ALLADIRETTIVA ATEX2014/34 /UE

Questi strumenti, in esecuzione antideflagrante certificata CESIATEX Ext.1 II 1/2G Exd IICT6/T5, permettono il controllo del livello di liquidi o carburante in serbatoi, sia interrati che all'aperto, installati in area classificata dove vengono trattati prodotti infiammabili.

APPROVED IN COMPLIANCE WITH 2014/34/EU ATEX DIRECTIVE

These explosion-proof tools (CESIATEX Ext.1 II 1/2G Exd IICT6/T5 certified) allow liquid or fuel level check in both underground and open-air tanks installed in a classified area where flammable products are treated.

IN ÜBEREINSTIMMUNG MIT DER RICHTLINIE ATEX 2014/34/EU ZUGELASSEN

Diese Instrumente in explosionsicherer, gemäß CESIATEX Ext.1 II 1 / 2G Exd IICT6 / T5 zertifizierter Ausführung, ermöglichen die Kontrolle des Füllstands von Flüssigkeiten oder Brennstoff in sowohl unterirdisch als auch im Freien montierten Tanks, die in einem klassifizierten Bereich installiert sind, in denen brennbare Produkte gehandhabt werden.

TECHNICAL DATASHEET

DATI ELETTRICI

Le ampole reed utilizzate nei livellostati sono ermeticamente sigillate, ad attuazione magnetica e con una affidabilità di milioni di cicli. Il tipo di contatto a riposo è in scambio (SPDT). La portata dei contatti varia secondo il tipo di ampolla reed adottata. Per i dati elettrici fare riferimento alla tabella sotto riportata.

ELECTRICAL DATA

The reed tubes used in the level switches are hermetically sealed, magnetically driven and characterised by a reliability of millions of cycles. At rest, it is a changeover contact (SPDT). Contact capacity varies according to the type of reed tube adopted. For further details about electrical data, refer to the table below.

DATEN DES ELEKTRISCHEN TEILS

Die Reed-Ampullen, die in den Füllstandwächtern verwendet werden, sind hermetisch versiegelt, werden magnetisch betätigt und weisen eine Zuverlässigkeit für Millionen an Zyklen auf. Der Ruhekontakt ist ein einpoliger Wechselschalter (SPDT-Single Pole Double Throw). Die Leistungsfähigkeit der Kontakte variiert mit dem angewendeten Typ der Reed-Ampulle.

Code Designation	Code ORDER	Potenza		Tensione		Corrente	
		VA	W	AC	DC	AC	DC
G_L5D	4411500001	20	20	150	150	0.5	0.5

Collegamenti elettrici standard::

Standard electrical connections:

Elektrische Standard-Verbindungen:

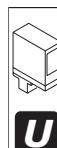
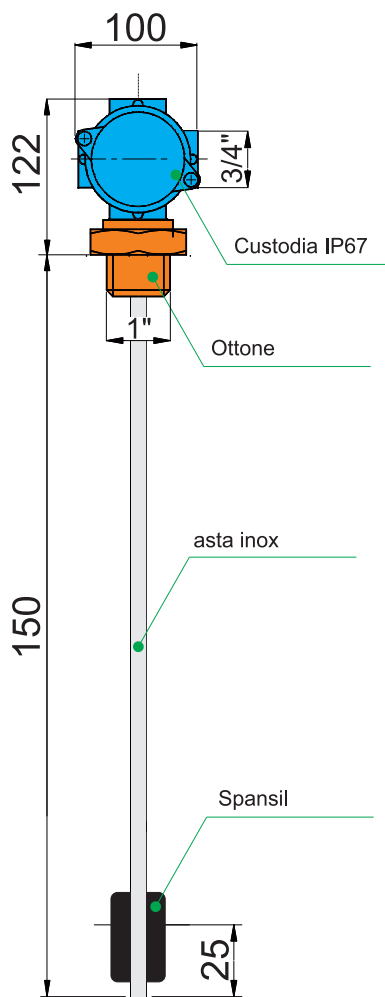
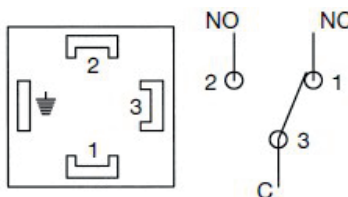



ACC7H

Accessori idraulici - HEATER

Hydraulic accessories - HEATER

Hydraulikzubehör - HEATER

7H HEATERS

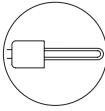

Dispositivi elettrici riscaldamento per avviamenti a basse temperature

Electrical heating devices for low temperature start-up

Elektrische Heizvorrichtungen für Starts bei niedrigen Temperaturen

Possono essere forniti i seguenti accessori e dispositivi:

Some devices can optionally be provided:

Folgende Zubehörteile und Vorrichtungen können geliefert werden:

Code Designation	Code ORDER	I	GB	DE
H W940	4401120053	Code HEATER	Code HEATER	Code HEATER
H W950	4401120054	Code HEATER	Code HEATER	Code HEATER
H W960	4401120055	Code HEATER	Code HEATER	Code HEATER
H W970	4401120056	Code HEATER	Code HEATER	Code HEATER
H W980	4401120057	Code HEATER	Code HEATER	Code HEATER
H W990	4401120058	Code HEATER	Code HEATER	Code HEATER
H W1000	4401120059	Code HEATER	Code HEATER	Code HEATER
H W1010	4401120060	Code HEATER	Code HEATER	Code HEATER
H W1020	4401120061	Code HEATER	Code HEATER	Code HEATER
H W1030	4402000008	Code HEATER	Code HEATER	Code HEATER

1 - Applicabilità

1 - Application

1 - Applikation

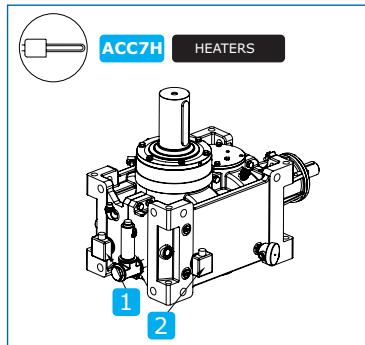

RXO1	1			2		
	CODE	CODE Designation	Note	CODE	CODE Designation	Note
802	4401120053	H W940	—	4401120054	H W950	—
804	4401120055	H W960		4401120053	H W940	
806	4401120055	H W960		4401120053	H W940	
808	4401120056	H W970		4401120055	H W960	
810	4401120057	H W980		4401120056	H W970	
812	4401120058	H W990		4401120057	H W980	
814	4401120059	H W1000		4401120058	H W990	
816	4401120059	H W1000		4401120059	H W1000	
818	4401120060	H W1010		4401120060	H W1010	
820	4401120061	H W1020		4401120061	H W1020	
822	4402000008	H W1030		4402000008	H W1030	
824	4402000008	H W1030		4402000008	H W1030	

RXO2	1			2		
	CODE	CODE Designation	Note	CODE	CODE designation	Note
814	4401120059	H W1000	—	4401120058	H W990	—
816	4401120059	H W1000		4401120059	H W1000	
818	4401120060	H W1010		4401120060	H W1010	
820	4401120061	H W1020		4401120061	H W1020	

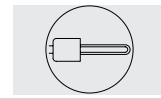

TECHNICAL DATASHEET



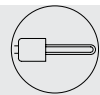

3.0 - Accessori idraulici

3.0 - Hydraulic accessories

3.0 - Hydraulikzubehör

TECHNICAL DATASHEET

Resistenza di preriscaldamento olio per avviamento riduttore a bassa temperatura. Il pilotaggio della termoresistenza deve avvenire mediante apposita apparecchiatura di controllo che ne comandi lo sgancio dell'alimentazione al raggiungimento della temperatura olio pre-impostata.

Oil preheating resistance for low-temperature gearbox start-up. The thermistor must be controlled by means of the corresponding control device that triggers power supply release once oil preset temperature is reached.

Heizwiderstand zur Vorwärmung des Öls für den Start bei niedrigen Temperaturen. Die Ansteuerung des Thermowiderstands muss über das entsprechende Kontrollgerät erfolgen, das die Trennung der Versorgung bei Erreichen der voreingestellten Öltemperatur steuert.

Caratteristiche costruttive generali

1 - Riscaldatori:

- Numero: 3;
- Tipo: riscaldatori corazzati piegati ad "U";
- Materiale: AISI 316 Ti;
- Diametro: \varnothing 10 mm;
- Sviluppo: a richiesta - sui rispettivi datasheets;
- Caratteristiche: ___W - ___V - a richiesta sui rispettivi datasheets;

2 - Attacco al processo:

- i riscaldatori sono elettrosaldati su tappo con le seguenti caratteristiche:
- Diametro: vedere tabella 2
 - Materiale: AISI 316
 - Plug Type: non applicabile

3 - Protezione Elettrica:

- IP65
- Materiale: Polycarbonato

4 - Dispositivi sicurezza:

- N° 1 - Termostato riarmo automatico scala 50/220 °C per controllo di sovratemperatura guaina temperatura di settaggio = 110 °C.

Caratteristiche tecniche

Nella TABLE 1 sono disponibili le seguenti informazioni tecniche

- 1 - Potenza Specifica [W/cm²];
- 2 - Potenza [W];
- 3 - Tensione [V];
- 4 - Corrente [A];
- 5 - Fluido:

Nella TABLE 2 sono disponibili i seguenti dati dimensionali:

- 6- Quote ingombro:

General manufacturing features

1 - Heating devices:

- Number: 3;
- Type: U-shaped shielded heating devices;
- Material: AISI 316 Ti; - Diameter: \varnothing 10 mm;
- Development: upon request - on the corresponding data sheets;
- Features: ___W - ___V - upon request on the corresponding data sheets;

2 - Connection to the process:

- the heating devices are electrically welded on the plug with the following features:*
- Diameter: see table 2
 - Material: AISI 316
 - Plug Type: not applicable

3 - Electrical protection:

- IP65
- Material: Polycarbonate

4 - Safety devices:

- No. 1 - Automatic reset thermostat scale 50/220 °C to control sheath overtemperature, preset temperature = 110 °C.*

Technical features

TABLE 1 contains the following technical information

- 1 - Specific power [W/cm²];
- 2 - Power [W];
- 3 - Voltage [V];
- 4 - Current [A];
- 5 - Liquid:

TABLE 2 contains the following dimensional data:

- 6- Overall dimensions:

Allgemeine Konstruktionsmerkmale

1 - Heizelemente:

- Anzahl: 3;
- Typ: gepanzerte U-förmige Heizelemente
- Material: AISI 316 Ti;
- Durchmesser: \varnothing 10 mm;
- Entwicklung: auf Anfrage - auf Basis der jeweiligen Datenblätter;
- Eigenschaften: ___W - ___V - auf Anfrage, auf Basis der jeweiligen Datenblätter;

2 - Anschluss an den Prozess:

- die Heizelemente sind auf einem Verschluss mit folgenden Eigenschaften elektrisch verschweißt
- Durchmesser: siehe Tabelle 2
 - Material: AISI 316-Plug Type: nicht anwendbar

3 - Elektrischer Schutz:

- IP65
- Material: Polycarbonat

4 - Sicherheitseinrichtungen:

- 1 - Thermostat mit automatischer Rücksetzung und einer Skala von 50/220°C für die Kontrolle der Überhitzung der Ummantlung, eingestellte Temperatur = 110 °C.

Technische Eigenschaften

Die TABLE 1 gibt folgende technische Informationen

- 1 - Spezifische Leistung [W/cm²];
- 2 - Leistung [W];
- 3 - Spannung [V];
- 4 - Strom [A];
- 5 - Flüssigkeit:

Die TABLE 2 stellt folgende Abmessungsdaten bereit:

- 6- Platzbedarf:

Dimensioni

Dimensions

Abmessungen

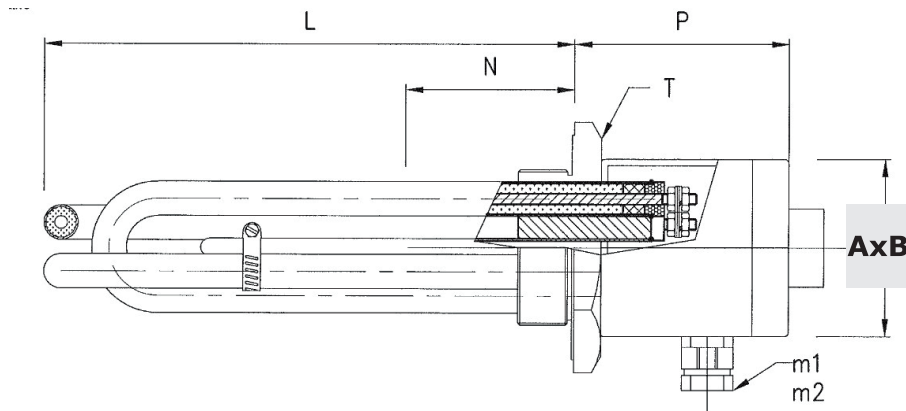



TECHNICAL DATASHEET

TABLE 1

Code Designation	Code Part GSM	Diameter [ø]	Power [w/cm ²]	Power [w]	Voltage [V]	Current [A]	Oil [ISO VG]
H_W940	4401120053	10 mm	1.2	300	230	1,3	220
H_W950	4401120054	10 mm	1.2	230	230	1	220
H_W960	4401120055	10 mm	1.2	340	230	1,5	220
H_W970	4401120056	10 mm	1.2	450	230	2	220
H_W980	4401120057	10 mm	1.2	520	230	2,3	220
H_W990	4401120058	10 mm	1.2	600	230	2,6	220
H_W1000	4401120059	10 mm	1.2	700	230	3	220
H_W1010	4401120060	10 mm	1.2	900	230	3,9	220
H_W1020	4401120061	10 mm	1.2	1050	230	4,6	220
H_W1030	4402000008	10 mm	1.2	1050	230	4,6	220

TABLE 2

Code Designation	Code Part GSM	A [mm]	B [mm]	L [mm]	N [mm]	R [mm]	T	P [mm]	m1	m2	T°
H_W940	4401120053	80	82	180	40	N.A.	1" 1/2 G	100	½ " Gas	N.A.	N.D.
H_W950	4401120054	80	82	150	40	N.A.	1" 1/2 G	100	½ " Gas	N.A.	N.D.
H_W960	4401120055	80	82	200	40	N.A.	1" 1/2 G	100	½ " Gas	N.A.	N.D.
H_W970	4401120056	80	82	240	40	N.A.	1" 1/2 G	100	½ " Gas	N.A.	N.D.
H_W980	4401120057	80	82	280	40	N.A.	1" 1/2 G	100	½ " Gas	N.A.	N.D.
H_W990	4401120058	80	82	310	40	N.A.	1" 1/2 G	100	½ " Gas	N.A.	N.D.
H_W1000	4401120059	80	82	350	40	N.A.	1" 1/2 G	100	½ " Gas	N.A.	N.D.
H_W1010	4401120060	80	82	450	40	N.A.	1" 1/2 G	100	½ " Gas	N.A.	N.D.
H_W1020	4401120061	80	82	500	40	N.A.	1" 1/2 G	100	½ " Gas	N.A.	N.D.
H_W1030	4402000008	80	82	500	40	N.A.	2" G	100	½ " Gas	N.A.	N.D.

Collegamenti Elettrici

Electrical connections

Elektrische Anschlüsse

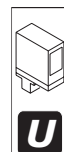
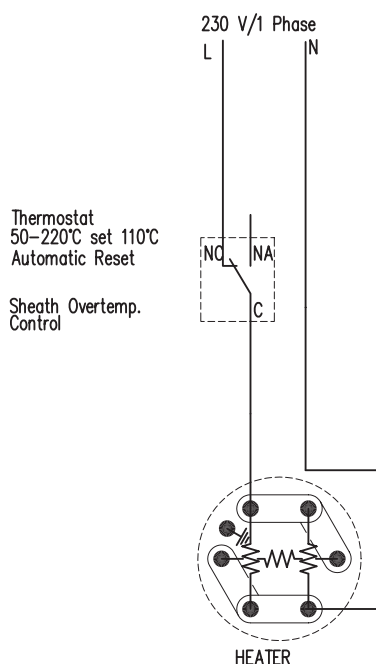



ACC711	Accessori idraulici - TEMPERATURE SENSOR	Hydraulic accessories - TEMPERATURE SENSOR	Hydraulikzubehör - TEMPERATURE SENSOR
---------------	---	---	--

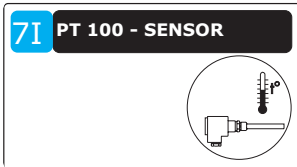

Per controllare la temperatura bagno olio. Il Pt100 può attivare un segnale d'allarme quando la temperatura dell'olio è superiore al limite specificato

To control the oil bath temperature. The Pt100 can trigger an alarm signal when the oil temperature is higher than a specified limit

Für die Kontrolle der Ölsumpftemperatur. Der Pt100 kann ein Alarmsignal auslösen, wenn die Öltemperatur über den vorgegebenen Grenzwert ansteigt

Possono essere forniti i seguenti accessori e dispositivi:

Some devices can optionally be provided:

Folgende Zubehörteile und Vorrichtungen können geliefert werden:

Code Designation	Code ORDER	I	GB	DE
I TPT1A	5031000013	= Sonda PT100 - Type1A		
I TPT2A	5031000042	= Sonda PT100 - Type2A		



TECHNICAL DATASHEET

I_TPT1A**SENSORE DI TEMPERATURA****DESCRIZIONE**

Sensore per il rilievo a distanza della temperatura.
La sonda di temperatura è realizzata con le seguenti caratteristiche.

Caratteristiche costruttive generali

- filo di platino con 100 Ω a 0 °C secondo EN 60751
- precisione classe A secondo EN 60751;
- campo di temperatura di funzionamento -40 °C + 200 °C;
- collegamento a tre fili secondo IEC 751
- sonda di acciaio inossidabile AISI 316; diametro 8 mm;
- Testa di connessione tipo DIN B
- grado di protezione IP66;
- entrata cavi G 1/2".

Per il collegamento del sensore al relativo dispositivo di controllo utilizzare cavo schermato di sezione 1,5 mm² posato separato dai cavi di potenza.

TEMPERATURE SENSOR**DESCRIPTION**

Sensor allowing temperature remote detection. The temperature probe is manufactured with the following features.

General manufacturing features

- *platinum wire with 100 Ω at 0 °C according to EN 60751*
- *class A accuracy according to EN 60751;*
- *operating temperature range -40 °C + 200 °C;*
- *3-wire connection according to IEC 751*
- *AISI 316 stainless steel probe; diameter 8 mm;*
- *terminal box DIN B;*
- *IP66 protection level;*
- *G 1/2" cable entry.*

To connect the sensor to the corresponding control device, use a shielded cable having a section of 1.5 sq.mm, separated from power cables.

TEMPERATURESENSOR**BESCHREIBUNG**

Sensor für die Fernfassung der Temperatur. Die Temperatursonde verfügt über die folgenden Eigenschaften.

Allgemeine Konstruktionsmerkmale

- Platindraht mit 100 Ω bei 0°C gemäß EN 60751
- Genauigkeitsklasse A gemäß EN 60751;
- Betriebstemperaturbereich -40 °C + 200 °C;
- 3-Draht-Verbindung gemäß IEC 751
- Sonde aus rostfreiem Stahl AISI 316; Durchmesser 8 mm;
- Klemmenkasten DIN B;
- Schutzart IP66;
- Kabeleingang G 1/2".

Für die Herstellung der Verbindung des Sensors an die entsprechende Kontrollvorrichtung ist ein abgeschirmtes Kabel mit einem Querschnitt von 1,5 mm² zu verwenden, das von den Leistungskabeln getrennt zu verlegen ist.

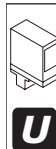

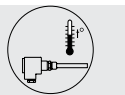

TECHNICAL DATASHEET

Collegamenti elettrici standard::

Standard electrical connections:

Elektrische Standard-Verbindungen:

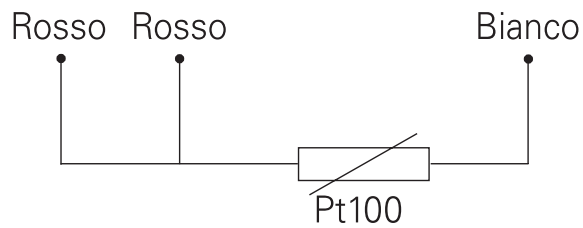

Dimensioni

Dimensions

Abmessungen

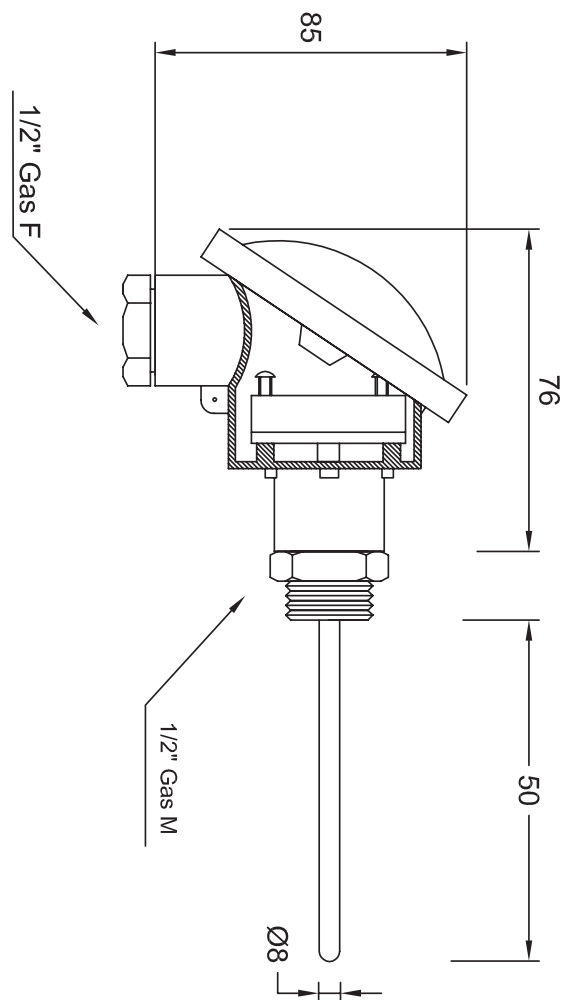



TECHNICAL DATASHEET

I_TPT2A

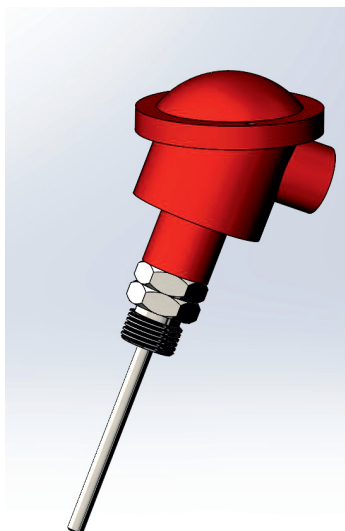

SENSORE DI TEMPERATURA

TEMPERATURE SENSOR

TEMPERATURENSOR

DESCRIZIONE

Sensore per il rilievo a distanza della temperatura. La sonda di temperatura è realizzata con le seguenti caratteristiche.

DESCRIPTION

Sensor allowing temperature remote detection. The temperature probe is manufactured with the following features.

BESCHREIBUNG

Sensor für die Fernfassung der Temperatur. Die Temperatursonde verfügt über die folgenden Eigenschaften.

Caratteristiche costruttive generali

General manufacturing features

Allgemeine Konstruktionsmerkmale

- filo di platino con 100 Ω a 0 °C secondo EN 60751
- Singolo elemento a 4 fili
- Trasmettitore di temperatura programmabile linearizzato 4+20 mA con protocollo HART.
- Scala -10+200 °C (altro da comunicare)
- Uscita 4+20 mA
- Alimentazione 10+36 VDC (tecnica a 2 fili)
- Precisione classe A IEC 751.
- Gambo inox Ø 6 mm
- Lunghezza 100 mm
- Attacco inox scorrevole filettato 1/2" Gas M cilindrico
- Testa di connessione tipo DIN B
- Esecuzione ATEX EEx-ia per applicazione in ambienti pericolosi
- Protezione IP 66

- platinum wire with 100 W at 0 °C according to EN 60751
- 4-wire individual element
- 4+20 mA linearised programmable temperature transmitter with HART protocol. -Scale -10+200 °C (other to be communicated)
- 4+20 mA output
- 10+36 VDC power supply (2-wire method)
- IEC 751 class A accuracy.
- Stainless stem Ø 6 mm
- Length 100 mm
- Cylindrical Gas M 1/2" threaded sliding stainless connection
- DIN B connection head
- ATEX EEx-ia operation for hazardous environment application
- IP 66 protection

- Platindraht mit 100 W bei 0°C gemäß EN 60751
- Einzelnes Element mit 4 Drähten
- Programmierbarer, linearisierter Temperaturegeber 4+20 mA mit HART-Protokoll.
- Skala -10+200 °C (weitere sind mitzuteilen)
- Ausgang 4+20 mA
- Versorgung 10+36 VDC (2-Draht-Technik)
- Genauigkeitsklasse A IEC 751.
- Schaft rostfreier Stahl Ø 6 mm
- Länge 100 mm
- Verschiebbarer Anschluss aus rostfreiem Stahl mit Gewinde 1/2" Gas M zylindrisch
- Anschlusskopf, Typ DIN B
- Ausführung ATEX EEx-ia für die Anwendung in gefährlichen Umgebungen
- Schutzart IP 66

-Certificato di taratura con rif. ACCREDIA su n°03 punti

-Calibration certificate with ACCREDIA ref. on no. 03 points.

-Eichzertifikat mit Bez. ACCREDIA an 03 Punkten

Per il collegamento del sensore al relativo dispositivo di controllo utilizzare cavo schermato di sezione 1,5 mm² posato separato dai cavi di potenza.

To connect the sensor to the corresponding control device, use a shielded cable having a section of 1.5 sq.mm, separated from power cables.

Für die Herstellung der Verbindung des Sensors an die entsprechende Kontrollvorrichtung ist ein abgeschirmtes Kabel mit einem Querschnitt von 1,5 mm² zu verwenden, das von den Leistungskabeln getrennt zu verlegen ist.

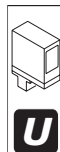

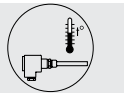

TECHNICAL DATASHEET

Dimensioni

Dimensions

Abmessungen

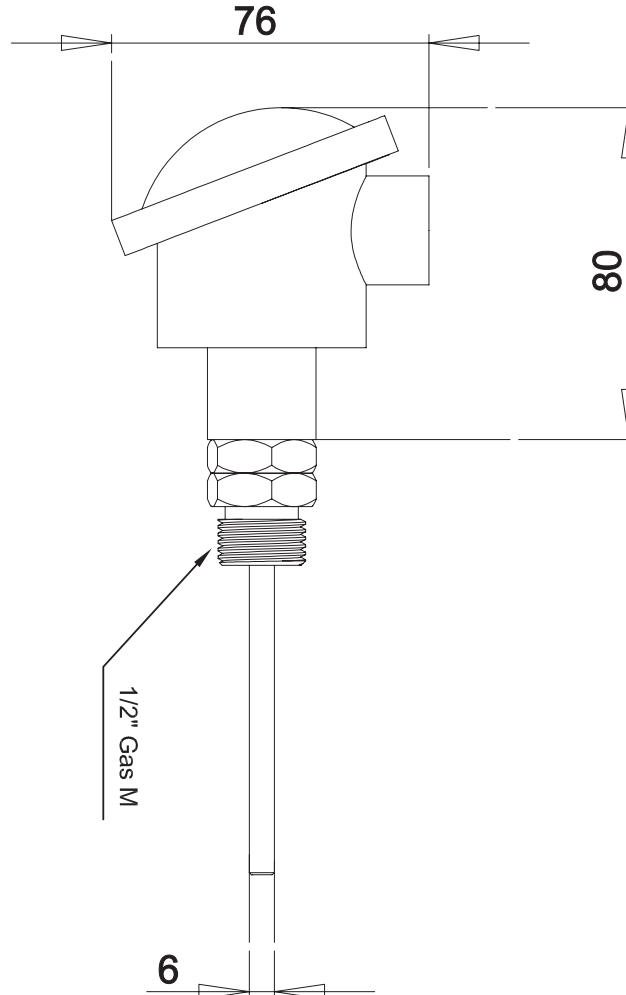

Trasmettitore a due fili con protocollo HART

2-wire transmitter with HART protocol

2-Draht-Geber mit HART-Protokoll



- Ingressi RTD, TC, Ohm, o mV
- Livello elevatissimo di precisione di misurazione
- Protocollo HART 5
- Isolamento galvanico
- Per supporto testa sensore DIN forma B

- RTD, TC, Ohm, or mV input
- Extremely high measurement accuracy
- HART 5 protocol
- Galvanic isolation
- For DIN form B sensor head mounting

- Eingänge RTD, TC, Ohm oder mV
- Höchste Messgenauigkeit
- Protokoll HART 5
- Galvanisch getrennt
- Für Abstützung des Sensorkopfs DIN Forma B



3.0 - Accessori idraulici

3.0 - Hydraulic accessories

3.0 - Hydraulikzubehör

TECHNICAL DATASHEET

Applicazione

-Misurazione temperatura linearizzata con sensore Pt100...Pt1000,Ni100...Ni1000, o TC.
 - Differenza o media di misurazione temperatura di 2 resistenze o sensori TC.
 - Conversione di variazione resistenza lineare a segnale di corrente analogico standard, per esempio da valvole o sensori di livello ohmici.
 - Amplificazione di segnale mV bipolare a un segnale di corrente standard 4...20 mA.
 -Collegamento di fino a 15 trasmettitori a un segnale digitale a due fili con comunicazione HART.

Application

-Linearized temperature measurement with Pt100...Pt1000,Ni100...Ni1000, or TC sensor.
 -Difference or average temperature measurement of 2resistance or TC sensors.
 -Conversion of linear resistance variation to a standard analogcurrent signal, for instance from valves or Ohmic levelsensors.
 -Amplification of a bipolar mV signal to a standard 4...20 mAcurrent signal.
 -Connection of up to 15 transmitters to a digital 2-wire signalwith HART communication.

Anwendung

-Linearisierte Temperaturmessung mit Sensor Pt100...Pt1000, Ni100...Ni1000 oder TC.
 - Differenz oder Mittelwert der Temperaturmessung von 2 Widerständen oder TC-Sensoren.
 - Umwandlung der linearen Widerstandsvariation in analoges Standard-Stromsignal, beispielsweise von Ventilen oder ohmschen Füllstandsensoren.
 - Verstärkung eines zweipoligen mV-Signals in ein Standard-Stromsignal 4...20 mA.
 - Anschlussmöglichkeit von bis zu 15 Gebern an ein digitales Signal mit zwei Drähten und HART-Kommunikation.

Caratteristiche tecniche

- In pochi secondi l'utente può programmare PR5335D affinché misuri le temperature in tutte le gamme definite dalle norme.
 -Gli ingressi RTD e di resistenza hanno una compensazione di cavo per il collegamento a 2, 3 e 4 fili.
 -Il 5335D è stato disegnato in conformità a severi requisiti di sicurezza e quindi è adatto per applicazione in installazioni SIL 2.
 - Controllo continuo di dati vitali salvati per motivi di sicurezza.
 -Rilevamento errore sensore secondo le linee guida in NAMURNE89.

Technical characteristics

-Within a few seconds the user can program PR5335D tomeasure temperatures within all ranges defined by the norms.
 -The RTD and resistance inputs have cable compensation for2-, 3- and 4-wire connection.
 -The 5335D has been designed according to strict safetyrequirements and is therefore suitable for application in SIL 2installations.
 -Continuous check of vital stored data for safety reasons.
 -Sensor error detection according to the guidelines in NAMURNE89.

Technische Eigenschaften

- Der PR5335D kann in nur wenigen Minuten vom Benutzer programmiert werden, um die Temperaturen in allen von den Normen vorgegebenen Bereichen zu messen.
 - Die Eingänge von RTD und des Widerstands haben einen Kabelabgleich für die 2-, 3- und 4-Drahtverbindung.
 - Der 5335D wurde in Übereinstimmung mit den strengsten Sicherheitsanforderungen entwickelt und eignet sich daher für den Einsatz in SIL 2 Installationen.
 - Dauerkontrolle der lebenswichtigen, aus Sicherheitsgründen gespeicherten Daten.
 - Erfassung eines Sensorfehlers laut Anweisungen in NAMURNE89.

Collegamenti elettrici standard::

Standard electrical connections:

Elektrische Standard-Verbindungen:

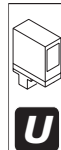
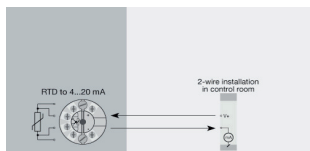



TECHNICAL DATASHEET

Condizioni ambientali	Environmental Conditions	Umgebungsbedingungen	
Gamma specifiche	Specifications range	Bereichsspezifikationen	-40°C to +85°C
Temperatura di calibrazione	Calibration temperature	Kalibriertemperatur	20...28°C
Umidità relativa	Relative humidity	Relative Feuchtigkeit	< 95% RH (non-cond.)
Grado di protezione (cust./morsettera)	Protection degree (encl./terminal)	Schutzart (Gehäuse/Klemmenkasten)	IP68 / IP00
Specifiche meccaniche	Mechanical specifications	Mechanische Spezifikationen	
Dimensioni	Dimensions	Abmessungen	ø 44 x 20.2 mm
Peso approssimativo	Weight approx.	Gewicht, ungefähr	50 g
Dimens. filo	Wire size	Maße Draht	1 x 1.5 mm ² stranded wire
Coppia vite morsetto	Screw terminal torque	Anzugmoment Klemmschraube	0.4 Nm
Vibrazione	Vibration	Schwingung	IEC 60068-2-6 : 2007
Vibrazione: 2...25 Hz	Vibration: 2...25 Hz	Schwingung: 2...25 Hz	± 1.6 mm
Vibrazione: 25...100 Hz	Vibration: 25...100 Hz	Schwingung: 25...100 Hz	± 4 g
Specifiche comuni	Common specifications	Allgemeine Daten	
Alimentazione	Supply voltage	Versorgung	8.0...30 VDC
Tensione isolamento, test/funzionamento	Isolation voltage, test /working	Isolierspannung, Test/Betrieb	1.5 kVAC / 50 VAC
Tempo risposta (programmabile)	Response time (programmable)	Ansprechzeit (programmierbar)	1...60 s
Tempo riscaldamento	Warm-up time	Heizdauer	30 s
Programmazione	Programming	Programmierung	Loop Link & HART
Rapporto segnale / rumore	Signal / noise ratio	Verhältnis Signal / Lärm	Min. 60 dB
Precisione	Accuracy	Genauigkeit	Better than 0.05% of selected range
Dinamica di segnale, ingresso	Signal dynamics, input	Signaldynamik, Eingang	22 bit
Dinamica di segnale, uscita	Signal dynamics, output	Signaldynamik, Ausgang	16 bit
Effetto del cambio di alimentazione	Effect of supply voltage change	Reaktion des Versorgungswechsels	< 0.005% of span / VDC
influenza immunità EMC	EMC immunity influence	Einfluss der Störfestigkeit EMV	< ± 0.1% of span
Immunità EMC estesa: NAMURNE 21, criterio A, scarica	Extended EMC immunity: NAMUR NE 21, A criterion, burst	Erweiterte Störfestigkeit EMV: NAMURNE 21, Kriterium A, Entladung	< ± 1% of span
Specifiche ingresso	Input specifications	Eingangsdaten	
Offset max.	Max. offset	Max. Offset	50% of selected max. value
Tipo RTD	RTD type	Typ RTD	Pt100, Ni100, lin. R
Resistenza cavo per filo (max.)	Cable resistance per wire (max.)	Kabelwiderstand pro Draht (max.)	5 Ω (up to 50 Ω per wire is possible with reduced measurement accuracy)
Corrente sensore	Sensor current	Sensorstrom	Nom. 0.2 mA
Effetto della resistenza del cavo del sensore (3-/4-fili)	Effect of sensor cable resistance (3-/4-wire)	Reaktion des Widerstands des Sensorkabels (3-/4-Drähte)	< 0.002 Ω / Ω
Rilevamento errore sensore	Sensor error detection	Erfassung des Sensorfehlers	Yes
Ingresso tensione	Voltage input	Spannungseingang	
Gamma misurazione	Measurement range	Messbereich	-800...+800 mV
Gamma min. misurazione (campo)	Min. measurement range (span)	Min. Messbereich (Feld)	2.5 mV
Resistenza ingresso	Input resistance	Eingangswiderstand	10 MΩ



TECHNICAL DATASHEET

Specifiche uscita	Output specifications		
Gamma segnale	Signal range	Output specifications	4...20 mA
Gamma segnale min.	Min. signal range	Ausgangsdaten	16 mA
Carico (@ uscita corrente)	Load (@ current output)	Signalbereich	$\leq (V_{supply} - 8) / 0.023 [\Omega]$
Stabilità carico	Load stability	Min. Signalbereich	$\leq 0.01\%$ of span / 100 Ω
Indicazione errore sensore.	Sensor error indication.	Last (@ Stromausgang)	Programmable 3.5...23 mA
NAMUR NE 43 Upscale/Downscale	NAMUR NE 43 Upscale/Downscale	Laststabilität	Programmable 3.5 23 mA
*del campo	*of span	*des Felds	= of the presently selected range
Requisiti rispettati per le autorità	Observed authority requirements	Für die Behörden eingehaltene Anforderungen	
EMC	EMC	EMC	2014/30/EU
Approvazioni	Approvals	Bescheinigungen	
ATEX 2014/34/EU	ATEX 2014/34/EU	ATEX 2014/34/EU	KEMA 03ATEX1537
IECEX	IECEX	IECEX	KEM 10.0083X
FM	FM	FM	2D5A7
CSA	CSA	CSA	1125003
INMETRO	INMETRO	INMETRO	NCC 12.0844 X
EAC	EAC	EAC	TR-CU 020/2011
EAC Ex TR-CU 012/2011	EAC Ex TR-CU 012/2011	EAC Ex TR-CU 012/2011	RU C-DK.GB08.V.00410
DNV Marine	DNV Marine	DNV Marine	Stand. f. Certific. No. 2.4
SIL	SIL	SIL	Hardware assessed for use in SIL applications

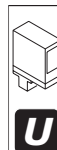

ACC7M2	Accessori idraulici - PRESSURE SWITCH	Hydraulic accessories - PRESSURE SWITCH	Hydraulikzubehör - PRESSURE SWITCH
---------------	--	--	---

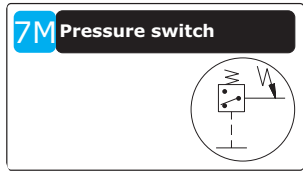

Per controllare la pressione dell'olio, può essere fornito un pressostato / trasmettitore di pressione. Possono attivare un segnale d'allarme quando la pressione scende al di sotto di un limite specifico.

To control the oil pressure, a pressure switch transmitter can be provided. They can trigger an alarm signal when the oil pressure falls beneath a specified limit.

Für die Öldruckkontrolle kann ein Druckschalter / Druckgeber geliefert werden. Diese können ein Alarmsignal auslösen, wenn der Druck unter den vorgegebenen Grenzwert sinkt.

Possono essere forniti i seguenti accessori e dispositivi:

Some devices can optionally be provided:

Folgende Zubehörteile und Vorrichtungen können geliefert werden:

Code Designation	Code ORDER	I	GB	DE
M_PSW1A	4200200001	= Pressostato - Type1A	= Pressure switch - Type1A	= Druckschalter - Type1A
M_PSW1B	4200200003	= Pressostato - Type1B	= Pressure switch - Type1B	= Druckschalter - Type1B

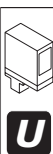



TECHNICAL DATASHEET



M_PSW1A

M_PSW1B

3.0 - Accessori idraulici

3.0 - Hydraulic accessories

3.0 - Hydraulikzubehör

TECHNICAL DATASHEET

PRESSOSTATO DI MINIMA

MINIMUM PRESSURE SWITCH

MINDESTDRUCKWÄCHTER

Il pressostato di minima controlla la pressione dell'olio e commuta due contatti in scambio quando tale pressione diminuisce al di sotto del valore di minima preimpostato.

Il valore di minima è da reimpostare a cura del Cliente ed è visualizzato da un indice che scorre sulla destra e si ottiene agendo sulla vite di regolazione posta sul frontale del pressostato.

Dati tecnici

Tensione massima 48 Vca/cc

Intensità di corrente 0.5(0.2) A

Campo di temperatura -5° + 60°C

Contatti:NO

Protezione con Coperchio in classe di protezione IP 65.

The low pressure switch controls the oil pressure and commutates two exchange contacts when the pressure decreases under the minimum value.

The minimum value to be preset by the Customer is shown by an index on the right and it is achieved by acting on the adjustment screw on the front of the pressure switch.

Technical data

Max voltage 48V ac/dc

Current intensity 0.5(0.2) A

Temperature range -5°/+60°

Contacts: NO

Protection with cover following IP65 protection class

Der Mindestdruckwächter überwacht den Öldruck und schaltet zwei Wechselkontakte, wenn dieser Druck unter den untersten voreingestellten Wert sinkt.

Der Mindestwert muss vom Kunden eingegeben werden und wird von einer rechts stehenden Anzeige angegeben. Die Einstellung erfolgt über die Einstellschraube, die vorne am Druckwächter angeordnet ist.

Technische Daten

Max Spannung 48V AC / DC

Stromstärke 0.5(0.2) A

Temperaturbereich -5°/+60°

Kontakte: NO

Schutzeinrichtung mit Deckel entsprechend Schutzart IP65

Designation	Code Part	ø D	Regulation range bar	Contact type	Max static pressure bar	Fixed Hysteresis at 25 °C bar	Tolerance at 25 °C bar	Execution	Set-point adjustment bar
M_PSW1A	4200200001	G 1/8 taper	0.15 - 2	NO	300	0.15	±0.2	Diaphragm	falling at 0.3
M_PSW1B	4200200003	G 1/8 taper	0.15 - 2	NC	300	0.15	±0.2	Diaphragm	falling at 0.3

M_PSW1A

NO

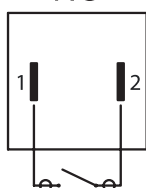

NC

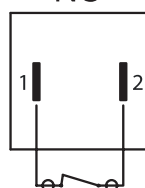

M_PSW1B

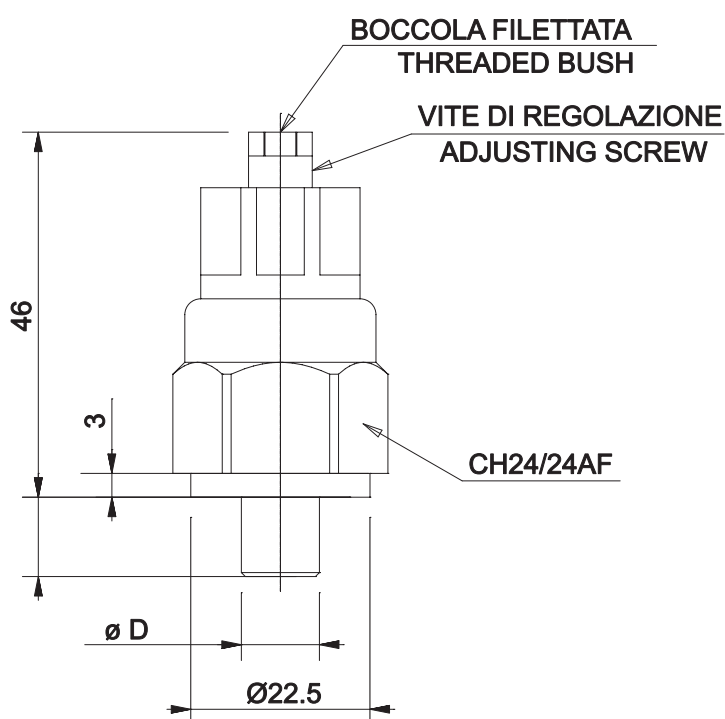

CAPPUCCHIO DI PROTEZIONE / PROTECTION CAP

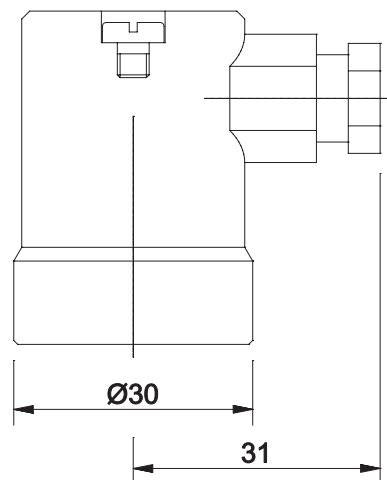

4250650001



4.0 - Anelli di tenuta

4.0 - Seals

4.0 - Dichtringe

ACC8	ACC8 - Accessori - Tipo Tenute	ACC8 - Accessories - Seal Type	ACC8 - Zubehör - Typ von Dichtung
-------------	---	---	--

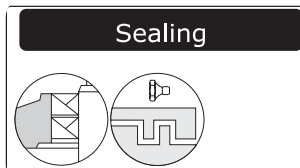

E' possibile richiedere diverse tipologie costruttive per realizzare la tenuta dinamica del riduttore.

It is possible to request various types of manufacturing to ensure the dynamic tightness of the gearbox.

Es können verschiedene Bauarten angefordert werden, um die dynamische Dichtigkeit des Getriebes zu erhalten.

Possono essere forniti i seguenti accessori e dispositivi:

Some devices can optionally be provided:

Folgende Zubehörteile und Vorrichtungen können geliefert werden:

Code Designation	Code ORDER	I	GB	DE
LB1		= Doppio anello di tenuta con labbro parapolvere con tenuta a labirinto in Entrata	= Double dust lip seal with Labyrinth seal - Input Shaft	= Doppeldichtung mit Staublippe mit Labyrinth-Dichtung - Antriebwelle
LB2		= Doppio anello di tenuta con labbro parapolvere con tenuta a labirinto in Uscita	= Double dust lip seal with Labyrinth seal - Output Shaft	= Doppeldichtung mit Staublippe mit Labyrinth-Dichtung - Abtriebwelle
LB		= Doppio anello di tenuta con labbro parapolvere con tenuta a labirinto in Albero Entrata + Albero Uscita	= Double dust lip seal with Labyrinth seal - Input shaft + Output shaft	= Doppeldichtung mit Staublippe mit Labyrinth-Dichtung - Antriebswelle + Abtriebswelle
DT1		= Doppio anello di tenuta con labbro parapolvere in Entrata	= Double dust lip seal - Input Shaft	= Doppeldichtung mit Staublippe - Antriebwelle
DT2		= Doppio anello di tenuta con labbro parapolvere e coperchio di protezione in Uscita	= Double dust lip seal with dust protection - Output Shaft	= Doppeldichtung mit Staublippe und Schutzabdeckung - Abtriebwelle
DT		= Doppio anello di tenuta con labbro parapolvere e coperchio di protezione in Albero Entrata + Albero Uscita	= Double dust lip seal with dust protection - Input shaft + Output shaft	= Doppeldichtung mit Staublippe Antriebswelle und Schutzabdeckung + Abtriebswelle

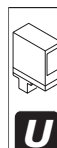



4.0 - Anelli di tenuta

4.0 - Seals

4.0 - Dichtringe

4.1 - Applicabilità

4.1 - Application

4.1 - Applikation

	RX01 - RXV1	RX02 - RXV2
DT1		
DT2		
DT		
LB1		
LB2		
LB		

4.2 - Albero Entrata

4.2 - Input shaft

4.2 - Antriebswelle

INPUT - PAM	INPUT - ECE		
Standard	Standard	Dust-proof	Radial labyrinth seal
<p>Un solo anello di tenuta con labbro parapolvere <i>One dust lip seal</i> <i>Ein einziger Dichtring mit Staublippe</i></p>	<p>Un solo anello di tenuta con labbro parapolvere e coperchio di protezione <i>One dust lip seal with dust protection</i> <i>Ein einziger Dichtring mit Staublippe und Schutzabdeckung.</i></p>	<p>Doppio anello di tenuta con labbro parapolvere. <i>Double dust lip seal</i> <i>Doppeldichtung mit Staublippe</i></p>	<p>Doppio anello di tenuta con labbro parapolvere con tenuta a labirinto. <i>Double dust lip seal with Labyrinth seal</i> <i>Doppeldichtung mit Staublippe mit Labyrinth-Dichtung</i></p>
	<p>Ambiente abbastanza polveroso Medium dust load with abrasive particles <i>Ziemlich staubiges Umfeld</i></p>	<p>Ambiente molto polveroso High dust load with abrasive particles <i>Sehr staubiges Umfeld</i></p>	<p>Ambiente estremamente polveroso Very High dust load with abrasive particles <i>Extrem staubiges Umfeld</i></p>
		<p>DT1 RXO-RXV</p>	<p>LB1</p>
	<p>Grease Not regreaseable</p>	<p>Grease Not regreaseable</p>	<p>Grease Regreaseable</p>



4.0 - Anelli di tenuta

4.0 - Seals

4.0 - Dichtringe

4.3 - Albero Uscita

4.3 - Output shaft

4.3 - Abtriebswelle

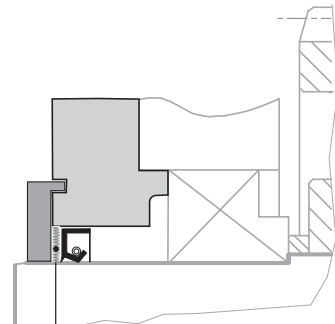
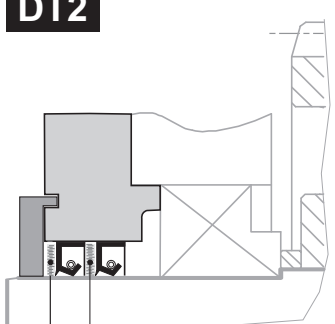
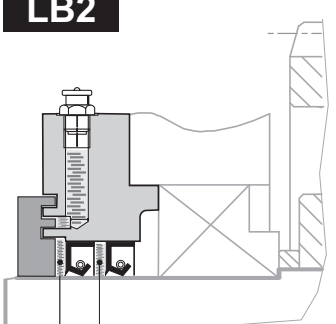
OUTPUT		
Standard	Dust-proof	Radial labyrinth seal
<p>Un solo anello di tenuta con labbro parapolvere e coperchio di protezione <i>One dust lip seal with dust protection</i> <i>Ein einziger Dichtring mit Staublippe und Schutzabdeckung.</i></p> <p>Ambiente abbastanza polveroso Medium dust load with abrasive particles Ziemlich staubiges Umfeld</p>	<p>Doppio anello di tenuta con labbro parapolvere e coperchio di protezione <i>Double dust lip seal with dust protection</i> <i>Doppeldichtung mit Staublippe und Schutzabdeckung.</i></p> <p>Ambiente molto polveroso High dust load with abrasive particles Sehr staubiges Umfeld</p>	<p>Doppio anello di tenuta con labbro parapolvere con tenuta a labirinto. <i>Double dust lip seal with Labyrinth seal</i> <i>Doppeldichtung mit Staublippe mit Labyrinth-Dichtung</i></p> <p>Ambiente estremamente polveroso Very High dust load with abrasive particles</p>
 <p style="text-align: center;">Grease Not regreaseable</p>	<p style="text-align: center;">DT2</p>  <p style="text-align: center;">Grease Not regreaseable</p>	<p style="text-align: center;">LB2</p>  <p style="text-align: center;">Grease Regreaseable</p>

4.4 - Albero Entrata + Albero Uscita

4.4 - Input shaft + Output shaft

4.4 - Antriebswelle + Abtriebswelle

DT	(DT1+DT2) Doppia tenuta in entrata ed in uscita	(DT1+DT2) Double seal at input and output end	(DT1+DT2) Doppeldichtung in An- und Abtrieb
LB	(LB1+LB2) Tenuta a labirinto in entrata ed in uscita	(LB1+LB2) <i>Labyrinth seal at input and output end</i>	(LB1+LB2) Labyrinthdichtung in An- und Abtrieb



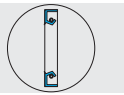

4.0 - Anelli di tenuta

4.0 - Seals

4.0 - Dichtringe

OPT	OPT - Opzioni - Materiale degli anelli di tenuta	OPT - Options - Materials of Seals	OPT - Optionen - Dichtungsstoffe
-----	--	---------------------------------------	-------------------------------------

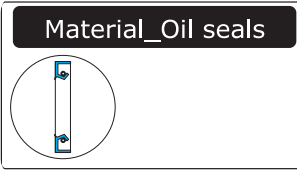

E' possibile richiedere materiali opzionali per gli anelli per la tenuta dinamica del riduttore.

It is possible to request optional material for the dynamic tightness of gearbox seal rings.

Es können Dichtringe aus optionalen Materialien für die dynamische Dichtigkeit des Getriebes angefordert werden.

Possono essere forniti i seguenti accessori e dispositivi:

Some devices can optionally be provided:

Folgende Zubehörteile und Vorrichtungen können geliefert werden:

Code Designation	Code ORDER	I	GB	DE
VT1		= Paraoli in viton in entrata	= <i>Viton oil seals at input end</i>	= Ölabdichtungen aus Viton im Antrieb
VT2		= Paraoli in viton in uscita	= <i>Viton oil seals at output end</i>	= Ölabdichtungen aus Viton im Abtrieb
VT		= Paraoli in viton in entrata ed in uscita	= <i>Viton oil seals at input and output end</i>	= Ölabdichtungen aus Viton im An- und Abtrieb
SL1		= Paraoli in silicone in entrata	= <i>Input Silicon oil seals</i>	= Eingehender Silikon-Dichtungsring
SL2		= Paraoli in silicone in uscita	= <i>Output Silicon oil seals</i>	= Ausgehender Silikon-Dichtungsring
SL		= Tenute in Silicone in Entrata - Uscita	= <i>Inpu and Output Silicon oil seals</i>	= Ein-und ausgehende Silikon-Dichtungsringe

4.0 - Anelli di tenuta

4.0 - Seals

4.0 - Dichtringe

4.1 - Applicabilità

4.1 - Application

4.1 - Applikation

	RX01 - RXV1	RX02 - RXV2 RX03 - RXV3
VT1		
VT2	A richiesta <i>On request</i> Auf Anfrage	
VT		
SL1		
SL2	A richiesta <i>On request</i> Auf Anfrage	
SL		

4.2 - Materiale degli anelli di tenuta

4.2 - Materials of Seals

4.2 - Dichtungstoffe

Serie <i>Series</i> Baureihe	OPT Opzioni - Materiale degli anelli di tenuta <i>Options - Materials of Seals</i> Optionen - Dichtungstoffe	
	— (Tenute STANDARD <i>Oil Seals Standard</i> Ölabdichtungen Standard) Opzioni - Disponibile <i>Options Available</i> Optionen - verfügbar
RX	— (NBR)	VT1 - VT2 - VT - SL1- SL2 - SL

NBR1	Paraoli in NBR in entrata	<i>NBR oil seals at input end</i>	Ölabdichtungen aus NBR im Antrieb
NBR2	Paraoli in NBR in uscita	<i>NBR oil seals at output end</i>	Ölabdichtungen aus NBR im Abtrieb
NBR	Paraoli in NBR in entrata ed in uscita	<i>NBR oil seals at input and output end</i>	Ölabdichtungen aus NBR im An- und Abtrieb
VT1	Paraoli in viton in entrata	<i>Viton oil seals at input end</i>	Ölabdichtungen aus Viton im Antrieb
VT2	Paraoli in viton in uscita	<i>Viton oil seals at output end</i>	Ölabdichtungen aus Viton im Abtrieb
VT	Paraoli in viton in entrata ed in uscita	<i>Viton oil seals at input and output end</i>	Ölabdichtungen aus Viton im An- und Abtrieb
SL1	Paraoli in silicone in entrata	<i>Input Silicon oil seals</i>	Eingehender Silikon-Dichtungsring
SL2	Paraoli in silicone in uscita	<i>Output Silicon oil seals</i>	Ausgehender Silikon-Dichtungsring
SL	Paraoli in silicone in entrata ed in uscita	<i>Input and output oil seals</i>	Ein- und ausgehende Silikon-Dichtungsringe

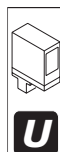

Gestione Revisioni Cataloghi GSM
Managing GSM Catalog Revisions
Management Wiederholt Kataloge GSM

STIM
team

Z

STIM
team



Gestione Revisioni Cataloghi GSM

Managing GSM Catalog Revisions

Management Wiederholt Kataloge GSM

Codice Catalogo

Catalog Code

Katalogcode

	GSM_mod.CT07	I	GB	D	1.0		
	N° Identificativo <i>Identification Number</i> Kennnummer	Identificativo Lingua - <i>Language</i> - Sprache I - Italiano – <i>Italian</i> - Italienisch GB – Inglese – <i>English</i> - Englisch D – Tedesco – <i>German</i> - Deutsch			Indice di Revisione <i>Review</i> Bericht		

1) Ogni catalogo GSM in distribuzione e' provvisto di un codice che lo identifica che è riportato nell'ultima pagina dei cataloghi e a piè pagina di tutte le pagine del catalogo stesso. Per verificare la revisione attualmente in vostro possesso è necessario guardare l'ultima cifra che compone il codice del catalogo:

1) Each GSM catalogue is identified by a code printed on the last page and reported in the page footer. The last digit in the catalogue code identifies catalogue revision:

1) Jeder, sich im Umlauf befindliche GSM-Katalog ist mit einer Identifikationsnummer versehen, der auf der letzten Seite und in den Fußnoten jeder einzelnen Seite aufgeführt ist. Um zu überprüfen, über welche Revision Sie im Augenblick verfügen, müssen Sie Bezug auf die letzte Ziffer der Katalogkennnummer nehmen.

2) Il catalogo che contiene gli ultimi aggiornamenti è reperibile sul sito internet STM. Le modifiche riportate sono visibili consultando la tabella degli aggiornamenti che è allegata a questo documento. Sulle pagine che sono oggetto della modifica è riportato l'indice di revisione cambiato.

2) Latest updated catalogues are available on STM's web site. Changes are listed in the updates table attached to this document. Any pages including a change are identified by a higher revision number.

2) Der Katalog, der die letzten Aktualisierungen enthält, kann von der Internetseite der STM herunter geladen werden. Die eingefügten Neuerungen können der Tabelle der Aktualisierungen entnommen werden, die diesem Dokument anhängt. Die Seiten, die Änderungen unterlagen, sind mit der geänderten Revisionsnummer versehen.

3) Guardare con attenzione il simbolo inserito nella colonna "Classificazione Modifica". In questa colonna sarà inserito un simbolo che determina una classificazione delle modifiche apportate. Questo consente di identificare con estrema rapidità l'importanza della modifica apportata;

3) Pay attention to the symbol in the "Change Classification" column. This symbol signifies the category and significance of any changes

3) Besonders auf das in die Spalte „Änderungsklasse“ eingefügte Symbol achten. In dieser Spalte wird das Symbol eingefügt, das für die Klasse der applizierten Änderungen steht.

Classificazione <i>Classification</i> Klasse	Definizione Specificante gli elementi di modifica <i>Definition Change identifier</i> Erklärende Definition der Änderungselemente	Simbolo Identificativo <i>Symbol</i> Identifikationssymbol
Chiave <i>Key</i> Schlüssel	Uscita e immissione di un prodotto <i>Product issuance and marketing</i> Ausgabe und Einführung eines Produkts	
Importante <i>Major</i> Wichtig	Modifica che influenza gli ingombri/stato fornitura/installazione del prodotto <i>Change affecting overall dimensions/delivery condition/product installation</i> Änderung, die sich auf die Abmessungen/Lieferzustand/Produktinstallation auswirkt	
Secondaria <i>Minor</i> Sekundär	Modifica che riguarda traduzioni/impaginazioni/inserimento descrizioni <i>Change to translations/layout/captions</i> Änderung, die Übersetzungen/den Umbruch/eingefügte Beschreibungen betrifft	—

4) Qualora risultasse una diversità di quote tra disegno **2D** – **3D** scaricato dal sito internet e tabella del catalogo è necessario consultare il nostro servizio tecnico.

4) In the event the dimensions in the 2D – 3D drawing downloaded from our site differ from those indicated in the catalogue table, contact our Engineering.

4) Diese ermöglicht ein schnelles Erfassen der Wichtigkeit der angesetzten Änderung.

Attenzione
Verificare la revisione in vostro possesso e la tabella degli aggiornamenti apportati nella nuova revisione.

Warning
Check your catalogue revision status against the latest updates table.

Achtung
Überprüfen Sie die Revision, die sich in Ihren Händen befindet, und die Tabelle der in der neuen Revision eingefügten Aktualisierung.

			Aggiornamenti apportati Updates made				
Codice Code	Indice Revision Index – Updates OLD	Sezione N° Section N°	Pagina Page OLD	Descrizione Description	Indice Revision Index – Updates NEW	Pagina Page NEW	Classificazione Modifica Update classification



Potenza richiesta / Required power / Benötigte Leistung

$P = \frac{m \cdot g \cdot v}{6 \cdot 10^4}$	Sollevamento <i>Lifting</i> Heben
$P = \frac{M \cdot n}{9550}$	Rotazione <i>Rotation</i> Drehung
$P = \frac{F \cdot v}{6 \cdot 10^4}$	Traslazione <i>Linear movement</i> Linearbewegung
$M = \frac{9550 \cdot P}{n}$	Coppia <i>Torque</i> Drehmoment
$F = 1000 \cdot \frac{M}{r}$	Forza <i>Force</i> Kraft
$v = \frac{2r \cdot \pi \cdot n}{1000}$	Velocità lineare <i>Linear speed</i> Lineargeschwindigkeit

Carichi radiali / Radial load / Radialkräfte

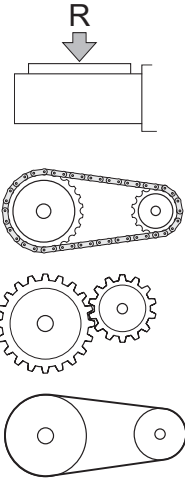

$R = \frac{2000 \cdot T \cdot Kr}{d}$	R (N) Carico radiale <i>Radial load</i> Radialkraft
$Kr = 1$ Ruota per catena <i>Chain-wheel</i> Kettenrad	T (Nm) Coppia sull'albero <i>Torque</i> Drehmoment
$Kr = 1.06$ Ingranaggio <i>Gear</i> Zahnrad	d (mm) Diametro della ruota <i>Diameter</i> Durchmesser
$Kr = 1.5-2.5-3.5$	1.5 - Cinghie dentate/Toothed belts/Zahnriemen 2.5 - Cinghie trapezoidali/V belt drives/Keilriemen 3.5 - Ruote di frizione (gomma su metallo) <i>Friction wheel drive (rubber on metal)</i> Kupplungsräder (Gummi auf Metall)

Momento d'inerzia

Moment of inertia

Trägheitsmoment

$J = 98 \cdot p \cdot l \cdot D^4$ Cilindro pieno / *Solid cylinder* / Vollzylinder
 $J = 98 \cdot p \cdot l \cdot (D^4 - d^4)$ Cilindro cavo / *Hollow cylinder* / Hohlzylinder

Conversione di una massa in movimento lineare in un momento d'inerzia riferito all'albero del motore

Conversion of a mass having a linear movement into a moment of inertia related to the motor shaft.

Umwandlung einer Masse mit Linearbewegung in ein Trägheitsmoment, das auf die Motorwelle bezogen ist.

$$J = 91.2 \cdot m \cdot \frac{v^2}{n^2}$$

















Conversione di diversi momenti d'inerzia di massa a velocità diverse in un momento d'inerzia riferito all'albero motore.

Conversion of various mass moments of inertia having different speeds into a moment of inertia related to the motor shaft.

Umwandlung von verschiedenen Trägheitsmomenten mit unterschiedlichen Geschwindigkeiten in ein Trägheitsmoment, das auf die Motorwelle bezogen ist.











$$J_a = \frac{J_2 \cdot n_2^2 + J_3 \cdot n_3^2 \dots}{n_1^2}$$

P	= Potenza motore	<i>Rated power</i>	Motorleistung	[kW]
m	= Massa	<i>Mass</i>	Masse	[kg]
v	= Velocità lineare	<i>Linear speed</i>	Lineargeschwindigkeit	[m/min]
F	= Forza	<i>Force</i>	Kraft	[N]
n	= Velocità di rotaz.	<i>Rotation speed</i>	Drehzahl	[min ⁻¹]
g	= 9.81	<i>9.81</i>	9.81	[m/sec]
M	= Coppia del motore	<i>Motor torque</i>	Motor-Drehmoment	[Nm]
r	= Raggio	<i>Radius</i>	Radius	[mm]
J	= Inerzia	<i>Moment of inertia</i>	Trägheitsmoment	[kgm ²]
l	= Lunghezza	<i>Length</i>	Länge	[mm]
d	= Diametro interno	<i>Inner diameter</i>	Innendurchmesser	[mm]
D	= Diametro esterno	<i>Outer diameter</i>	Außendurchmesser	[mm]
p	= Peso specifico	<i>Specific weight</i>	Spezifisches Gewicht	[kg/dm ³]

	 PIEMONTE Strada del Cascinotto, 139/43B 10156 TORINO T: +39/011/22.38.463 F: +39/011/22.38.463 E-MAIL: info@labet.it	 LOMBARDIA Via Velleia, 1 20052 Monza (Mi) T: +39/039/83.79.41 F: +39/039/83.79.490 E-MAIL: sef@sefmotoriduttori.com
 SUD Via Ottaviano, 298/300 80040 San Gennaro Vesuviano (Na) T: +39/081/52.86.802 F: +39/081/52.86.803 E-MAIL: info@stmsud.it	 VENETO Via Manfredini, 54 45100 Loc. Granzette ROVIGO T: +39/0425/48.61.58 F: +39/0425/93.20.68 E-MAIL: stmveneto@stmspa.com	 SERVICE Via Enrico Fermi, 35 00044 Frascati (RM) T: +39/06/97.60.85.44 F: +39/06/97.60.85.45 E-MAIL: info@tecnodivesrl.it
	 UKRAINE Belaia Tzerkov Yaroslava Mudrogo, ST66/13 09107 Region of Kiev T: +38/04463519369 F: +38/0446391037 E-MAIL: stm@stm.com.ua	 RUS Bolshaya Pochtovaya st. 30 105082 Mosca T: +74/957836809 F: +74/952672073 E-MAIL: ars@ttaars.ru
 AANDRIJFTECHNIEK NL Jan Vrijmanstraat, 12 1087MC, Amsterdam - The Netherlands T: + 31/20 3586361 F: +31/20 3586361 E-MAIL: stmaandrijftechniek@stmspa.com	 SWEDEN Stathogavagen, 48 60223 Norrkoping T: +46/11158340 F: +46/11158349 E-MAIL: info@stmSweden.se	 FINLAND Luoteisrinne, 5 02270 Espoo T: +35/8440674519 F: +35/8104256805 E-MAIL: info@stmfinland.fi
 DEUTSCHLAND Gewerbepark Markfeld 7a 83043 BAD AIBLING T: +49/8061/937680 F: +49/8061/9376829 E-MAIL: stmdeutschland@stmspa.com	 POWER TRANSMISSION UK UNIT 1 OASIS BUSINESS PARK ROAD ONE, WINSFORD Industrial Est - CW7 3RY - WINSFORD T: +44/1606/557200 F: +44/1606/557396 E-MAIL: info@stmuk.co.uk	 IBERIA Contrada Nacional 121, km 39,400 31390 Olite Navarra T: +34/948712017 F: +34/948712153 E-MAIL: martinena@martinenasl.es
 SCHWEIZ Bösch 27 6331 Hünenberg SVIZZERA T: 0041 41 7832970 F: 0041 41 7832971 E-MAIL: info@eurodrives.ch	 TURKIYE 10026 - IZMIR Str. No: 54 AOSB CIGLI T: 0090.232.328 36 39 F: 0090.232.328 36 40 E-MAIL: info@novaguc.com	



Vi invitiamo pertanto a contattare il ns ufficio commerciale per qualsiasi ulteriore informazione al fine di comunicarVi il riferimento più idoneo e vicino alla Vs sede.
 Please contact our Sales dept. for information about the nearest distributor to your premises.
 Bitte setzen Sie sich mit unserer Verkaufsabteilung in Verbindung um Informationen bezüglich eines Haendler der sich in Ihrer Naehle befindet zu bekommen.

	 Rua Padre Raposo, 1293 Mooca (SP) T: +55/11/2605.1144 F: +55/11/2601.1559 E-MAIL: stmdobrasil@stmdobrasil.com	 Langeri, 3525 (Santos Lugares) 1676 Buenos Aires T: +54/11/41.15.63.85 F: +54/11/47.57.05.12 E-MAIL: comercial@stmteam.com.ar
 STM INDIA T: +91 99 42 559285 E-MAIL: k.saravanan@stmspa.com	 13/97 Bayfield Road East Bayswater - VIC 3153 T: +61/397617355 F: +61/397617222 E-MAIL: pbeveridge@hmaqgroup.com.au	 STM-AP (ASIA PACIFIC) PTE LTD 6 Penjuru Place #01-32 Penjuru Tech Hub, Singapore 608781 T: 65-6266 2022 F:65-6266 5955 E-MAIL: stm@stmmap.com
 STM Korea #104-216, 41, Yutongdanji 1-ro, Gangseo-gu, Busan, 618-899 Rep. of KOREA T: +82-01-8536-6469 - +82-70-8730-1238 F: +82-51-955-2250 E-MAIL: stmmapkorea@gmail.com	 Rm306, Blk A, Jingjiang Building, #35, Bagou Nan Rd, Haidian Dist. Beijing 100089, China T: 0086 10 8256 5319 F: 0086 10 8255 1142 E-MAIL: stm@stmchina.cn	 22 Lorna Rd, Anderbolt, Boksburg North PO Box 6300, Dunswart, 1508 Tel: +27 10 010 6879 F: +27 86 461 5898 E-MAIL: anthony@stmrsa.co.za
<p>High Tech line GSM_mod. CT 07 IGBD1.0 09/17</p>	 STM RIDOTTORI MEXICO S.A. DE C.V T: +52 33 36150087 E-MAIL: info@stmexico.com.mx	 3060 PLAZA DR. #107 19061 - GARNET VALLEY - PA T: 0016105580760 F: 0016505580762 E-MAIL: Info@youngpowertech.com

Questo catalogo annulla e sostituisce ogni precedente edizione o revisione. I dati esposti nel catalogo non sono impegnativi e ci riserviamo il diritto di apportare eventuali modifiche senza darne preavviso, nell'ottica di un miglioramento continuo del prodotto.

Qualora questo catalogo non Vi sia giunto in distribuzione controllata, l'aggiornamento dei dati ivi contenuto non è assicurato.

In tal caso la versione più aggiornata è disponibile sul ns. sito internet: www.stmspa.com

This catalogue cancels and replaces any preceding issue or revision. The data provided in the catalogue are not binding; in line with our commitment to on-going product improvement, we reserve the right to make changes without prior notice.

If you obtained this catalogue other than through controlled distribution channels, no warranty is made as to whether the data contained herein is up-to-date.

When in doubt, you are welcome to download the latest up-to-date version available on our web site: www.stmspa.com

Dieser Katalog annulliert und ersetzt jede vorausgehende Ausgabe oder Revision. Die im vorliegenden Katalog enthaltenen Daten sind nicht verpflichtend. Wir behalten uns diesbezüglich das Recht vor, ohne entsprechende Vorankündigungen und im Sinne einer kontinuierlichen Produktverbesserung eventuelle Änderungen anfragen zu können. Sollten Sie diesen Katalog nicht im Zuge eines kontrollierten Vertriebs erhalten haben, kann die Aktualisierung der darin enthaltenen Daten nicht gewährleistet werden.

In diesem Fall finden Sie die aktuellste Version unter der Website: www.stmspa.com



Vi invitiamo pertanto a contattare il ns ufficio commerciale per qualsiasi ulteriore informazione al fine di comunicarvi il riferimento più idoneo e vicino alla Vs sede.
 Please contact our Sales dept. for information about the nearest distributor to your premises.
 Bitte setzen Sie sich mit unserer Verkaufsabteilung in Verbindung um Informationen bezüglich eines Haendler der sich in Ihrer Naehe befindet zu bekommen.



STM S.p.A.
Headquarter

Via del Maccabreccia, 39
40012 Lippo di Calderara di Reno (BO)
Tel. +39 051 37 65 711
Fax +39 051 64 66 178
www.stmspa.com - info@stmspa.com



Riduttori

GSM S.p.A.

Via Malavolti, 48
41122 Modena - Italy
Tel. +39 051 37 65 711
Fax +39 051 64 66 178
www.stmspa.com - info@stmspa.com

